

thorax, herz, gefäße

# cardiovascular

cardiovascular  
cardiovasculaire  
cardiovascolare



**nopa<sup>®</sup>** Instruments

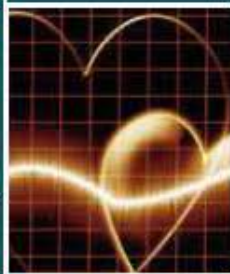

cardiovascular basic set	>> Cardiovascular • Cardiovascular • Cardiovascular • Cardiovasculaire • Cardiovascolare 9–18
endarterectomy set	>> Endarteriektomie • Endarterectomy • Endarterectomia • Endarterectomie • Endarterectomia 19–24
thoracotomy set	>> Thorakotomie • Thoracotomy • Thoracotomia • Thoracotomie • Thoracotomia 25–30
coronary bypass set	>> Koronar Arterien-Bypass • Coronary Bypass • Bypass coronario Pontage aorto-coronarien • Bypass aorto-coronarico 31–34

>> Klemmen • Hemostats • Pinzas hemostáticas Pinces hémostatiques • Pinze emostatiche	35-68	AA
>> Pinzetten • Forceps • Pinzas • Pinces • Pinze	69-88	AB
>> Scheren • Scissors • Tijeras • Ciseaux • Forbici	89-128	AC
>> Skalpelle • Scalpels • Bisturies • Bistouris • Bisturi	129-134	AD
>> Naht • Suture • Sutura • Suture • Sutura	135-162	AE
>> Tupferzangen • Sponges Forceps • Pinzas para pólipos Pinces à pansements • Pinze per polipi	163-170	AF
>> Wundhaken • Retractors • Separadores • Ecarteurs • Divaricatori	171-198	AK
>> Gefäßinstrumente und Sonden • Vessel instruments and probes • Instrumental vascular y sondas Instruments vaisseaux et sondes • Strumenti vascolari e sonde	199-210	AL
>> Saugrohre und Kanülen • Suction tubes and cannulae • Tubos de aspiración y canulas Tubes d'aspiration et canules • Tubi d'aspirazione e cannule	211-216	AO
>> Knocheninstrumente • Bone instruments • Instrumentos para huesos Instruments des os • Strumenti per ossa	217-232	KA
>> Herz/Thorax • Cardiovascular • Cardiovascular • Cardiovasculaire • Cardiovascolare	233-300	KK
>> Endoskopie • Endoscopy • Endoscopia • Endoscopie • Endoscopia	301-344	X

## KYE

- >> Bitte fordern Sie unseren Spezialkatalog für Sterilisationscontainer an.
- >> Please request for our special catalogue for Sterilization Containers.
- >> Por favor pida por nuestro catálogo especial de contenedores de esterilización.
- >> Nous vous prions de demander notre catalogue spécial des conteneurs de sterilisation.
- >> Chieda prego il nostro catalogo per contenitori di sterilizzazione.





---

CARDIOVASCULAR BASIC  
CARDIOVASCULAR BASIC  
CARDIOVASCULAR BASIC  
CARDIOVASCULAIRE BASIC  
CARDIOVASCOLARE BASIC

**SET**

ZS 941/10

Siebvorschlag - Suggested instrument set



ZS 941/10	Contents:	Qty
AA 150/12	HALSTED-MOSQUITO FCPS STR 12,5 CM	1
AA 151/12	HALSTED-MOSQUITO FCPS CVD 12,5 CM	6
AA 180/14	CRILE FORCEPS STR 14,0 CM	2
AA 181/14	CRILE FORCEPS CVD 14,0 CM	12
AA 201/20	ROCHESTER-PEAN FCPS CVD 20,0 CM	1
AA 210/16	OCHSNER-KOCHER ART. FCPS STR 16,0 CM	10
AA 239/18	ADSON FORCEPS CVD 18,5 CM	3
AA 300/16	ROCHESTER-CARMALT FCPS STR 16,0 CM	10
AA 320/02	HEISS FORCEPS SLIGHTLY CVD 20,0 CM	10
AA 330/24	CRAFOORD ARTERY FORCEPS CVD 24,0 CM	3
AA 345/19	MIXTER FORCEPS CVD 19,0 CM	6
AA 751/08	BACKHAUS TOWEL FORCEPS 8,0 CM	6
AA 751/13	BACKHAUS TOWEL FORCEPS 13,0 CM	6
AB 060/14	STANDARD TISSUE FCPS 1X2 T STR 14,5 CM	2
AB 100/12	ADSON DRESSING FORCEPS 12,0 CM	1
AB 117/09	ADSON-BROWN TISS. FCPS CVD 9X9 T 12,0 CM	2
AB 200/18	POTTS-SMITH DRESSING FORCEPS STR 18,0 CM	3
AB 480/15	RUSS.MODEL TISSUE FCPS 15,0 CM	2
AB 480/20	RUSS.MODEL TISSUE FCPS 20,0 CM	2
AB 862/20	DE BAKEY ATRAUMA FCPS STR 2,0 MM 20,0 CM	4
AB 862/24	DE BAKEY FCPS STR 2,0 MM 24,0 CM	2
AC 072/17	MAYO-STILLE OPER. SCS STR BL/BL 17,0 CM	2
AC 073/17	MAYO-STILLE OPER. SCS CVD BL/BL 17,0 CM	2
AC 087/18	KELLY FISTULA SCISSORS CURVED 18,0 CM	1
AC 111/18	METZENBAUM-NELSON SCS CVD BL/BL 18,0 CM	1
AC 111/20	METZENBAUM-NELSON SCS CVD BL/BL 20,0 CM	1
AC 219/25	POTTS-SMITH ART. SCS 25 DEGREE 19,0 CM	1
AC 219/45	POTTS-SMITH ART. SCS 45 DEGREE 19,0 CM	1
AC 941/20	METZENBAUM SCS TUC CVD BL/BL 20,0 CM	1
AC 987/12	UNIVERSAL WIRE SHEARS TUC 12,0 CM	2
AD 010/03	SCALPEL HANDLE NO. 3	6
AD 020/13	SCALPEL HANDLE NO. 3 L	6
AE 100/16	MAYO-HEGAR NEEDLE HOLDER 16,0 CM	3
AE 100/18	MAYO-HEGAR NEEDLE HOLDER 18,0 CM	5
AE 100/20	MAYO-HEGAR NEEDLE HOLDER 20,0 CM	3
AF 200/25	FOERSTER-BALLENGER STR SERRATED 25,0 CM	8
AK 036/01	CUSHING DELICATE HOOK FIG.1 19,0 CM	2
AK 102/10	CUSHING RETRACTOR 10 MM 24,0 CM	2
AK 122/16	SENN-MILLER RETRACTOR SHARP 16,0 CM	4
AK 150/04	VOLKMANN RETR.SHARP 4 PRONGS 21,5 CM	4
AK 245/17	MIDDELDORPF RETRACTOR 14X17 MM 21,5 CM	2
AK 247/01	RICHARDSON RETRACTOR 28X20 MM 24,0 CM	2
AK 247/02	RICHARDSON RETRACTOR 36X28 MM 24,0 CM	2
AK 247/03	RICHARDSON RETRACTOR 44X38 MM 24,0 CM	2
AK 247/04	RICHARDSON RETRACTOR 52X22 MM 24,0 CM	2
AK 300/04	DEAVER RETRACTOR WIDTH 25 MM 30,0 CM	2
AK 300/08	DEAVER RETRACTOR WIDTH 50 MM 30,0 CM	1
AK 300/09	DEAVER RETRACTOR WIDTH 75 MM 30,0 CM	2
AK 374/00	PARKER RETRACTOR SET LARGE FIG.1+2	1
AK 384/00	PARKER-LANGENBECK US-ARMY SET FIG.1+2	1
AK 520/13	WEITLANER RETRACTOR SHARP 13,0 CM	2
AK 580/19	GELPI RETRACTOR 19,0 CM	2
AK 804/30	ABDOMINAL SPATULA 33,0 CM	1
AK 804/40	ABDOMINAL SPATULA 33,0 CM	1
AK 804/50	ABDOMINAL SPATULA 33,0 CM	1

ZS 941/10	Contents:	Qty
AO 400/00	YANKAUER SUCTION TUBE COMPLETE	2
AO 404/00	WALTON-YANKAUER SUCTION TUBE	2
AO 421/22	POOLE SUCTION TUBE CURVED 8 MM 22,0 CM	1
AO 430/10	FRAZIER BRAIN SUCTION TUBE CHARR10/17,00 CM	1
KA 520/40	WILLIGER MALLETS 400G 30 MM DIAM.	1
KD 055/15	ALLIS FCPS 5x6T 15,0 CM	6
KD 055/19	ALLIS TISSUE FCPS 5X6 T 19,0 CM	3
KD 060/15	ALLIS-ADAIR TIS. SEIZ. FCPS 10X11 15,0 CM	4
KD 111/16	BABCOCK INT. TISSUE FCPS 16,0 CM	4
KK 040/25	LEBSCHER CHISEL 25,0 CM	1
KYE 301/07	WIRE BASKET, 540 X 255 X 70 MM	2

Sterilization Container KYE 200/71, if required.

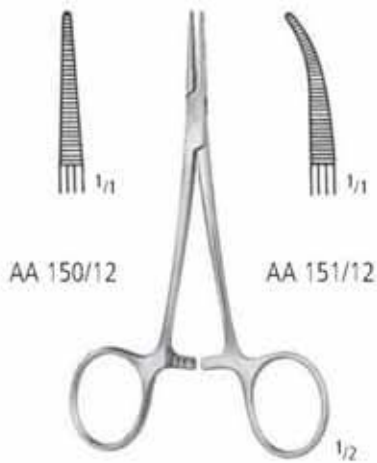

AA 150/12

AA 151/12

**HALSTED-MOSQUITO**  
12,5 cm/5"

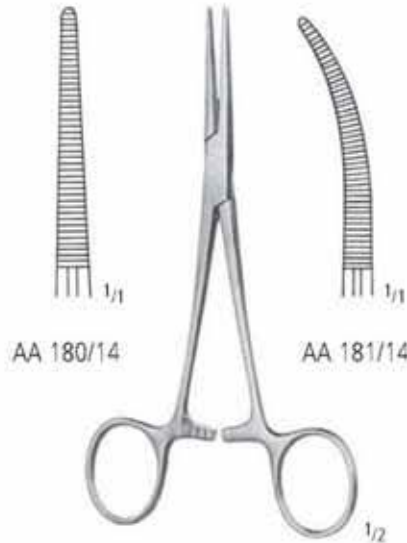

AA 180/14

AA 181/14

**CRILE**  
14,0 cm/5 1/2"

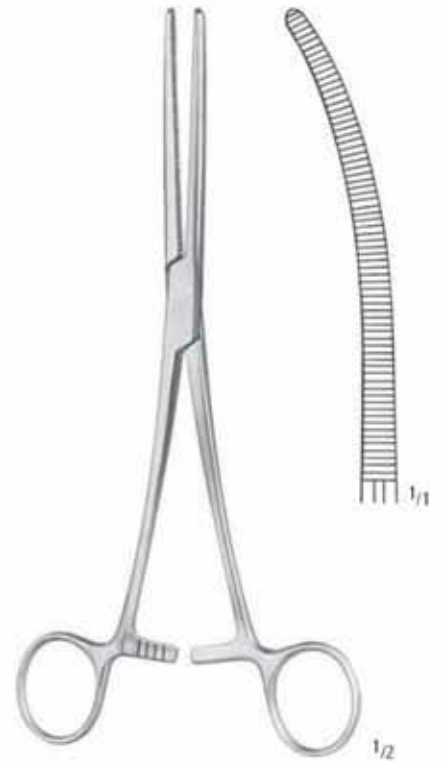

**ROCHESTER-PEAN**  
AA 201/20  
20,0 cm/8"



**OCHSNER-KOCHER 1:2**  
AA 210/16  
16,0 cm/6 1/4"



**ADSON**  
AA 239/18  
18,5 cm/7 1/3"

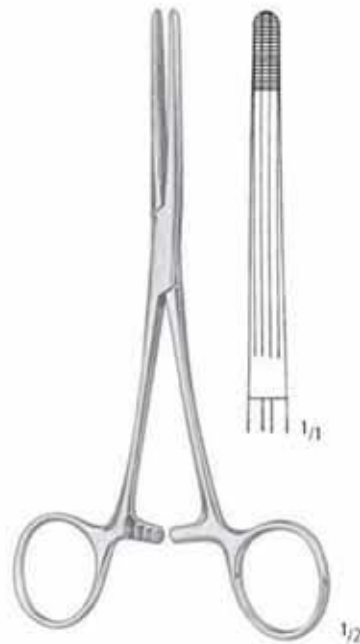

**ROCHESTER-CARMALT**  
AA 300/16  
16,0 cm/6 1/4"



**HEISS**  
AA 320/02  
20,0 cm/8"

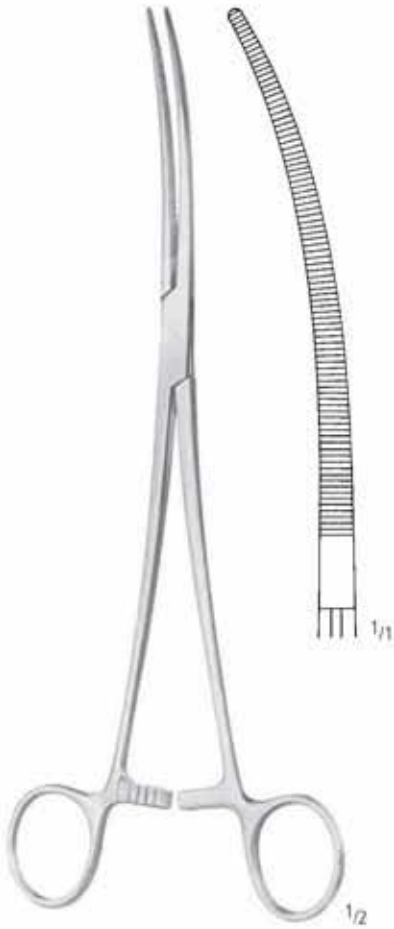

**CRAFOORD**  
AA 330/24  
24,0 cm/9<sup>1</sup>/<sub>2</sub>"



**MIXTER**  
AA 345/19  
19,0 cm/7<sup>1</sup>/<sub>2</sub>"

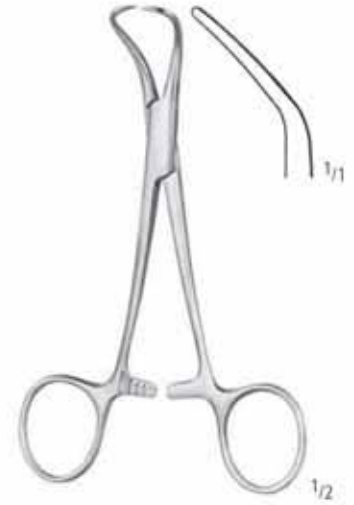

**BACKHAUS**  
8,0 cm/3" AA 751/08  
13,0 cm/5" AA 751/13



**STANDARD 1:2**  
AB 060/14  
14,5 cm/5<sup>3</sup>/<sub>4</sub>"



**ADSON**  
AB 100/12  
12,0 cm/4<sup>3</sup>/<sub>4</sub>"



**ADSON-BROWN**  
AB 117/09  
12,0 cm/4<sup>3</sup>/<sub>4</sub>"



**POTTS-SMITH**  
AB 200/18  
18,0 cm/7"



**RUSS. MODELL**  
15,0 cm/6" AB 480/15  
20,0 cm/8" AB 480/20



**DE BAKAY**  
20,0 cm/8" AB 862/20  
24,0 cm/9<sup>1</sup>/<sub>2</sub>" AB 862/24

9 : 9



Fistelscheren  
Fistula Scissors  
Tijeras para fistulas  
Ciseaux pour fistules  
Forbici per fistole



**MAYO-STILLE**  
AC 072/17  
17,0 cm/6<sup>1</sup>/<sub>4</sub>"

**MAYO-STILLE**  
AC 073/17  
17,0 cm/6<sup>1</sup>/<sub>4</sub>"

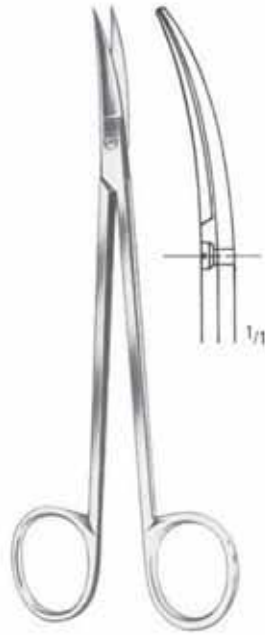

**KELLY**  
AC 087/18  
18,0 cm/7"

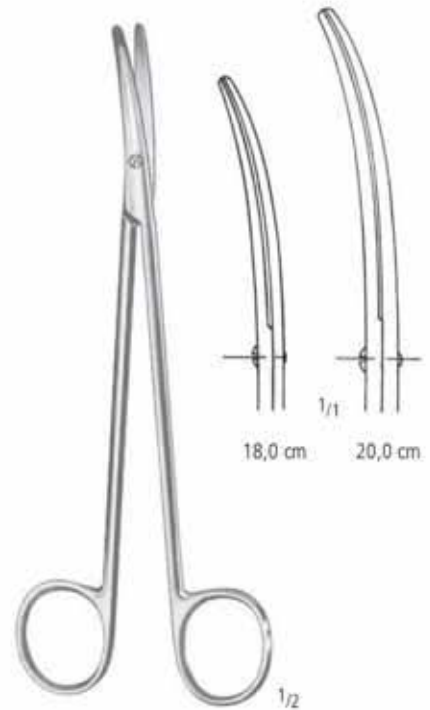

**METZENBAUM-NELSON**  
18,0 cm/7" AC 111/18  
20,0 cm/8" AC 111/20



**POTTS-SMITH**  
19,0 cm/7<sup>1</sup>/<sub>2</sub>"

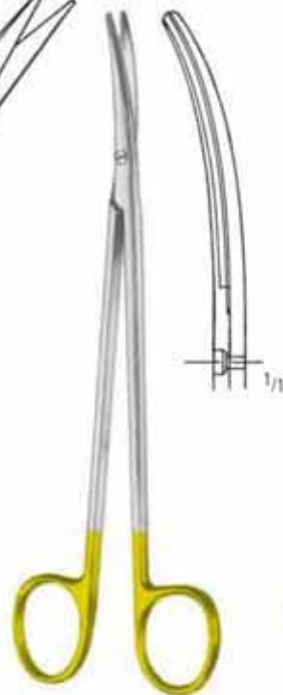

**METZENBAUM**  
AC 941/20 SC  
20,0 cm/8"

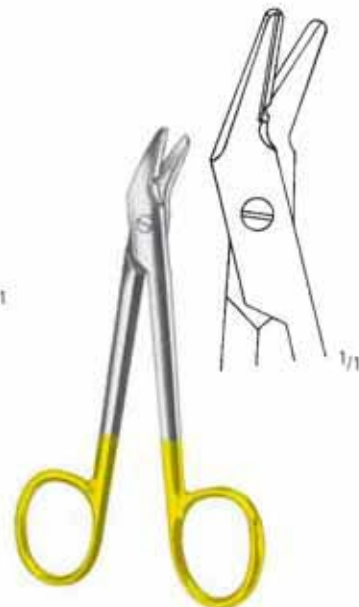

**UNIVERSAL**  
AC 987/12  
12,0 cm/4<sup>3</sup>/<sub>4</sub>"



AD 010/03  
No. 3

AD 020/13  
No. 3L

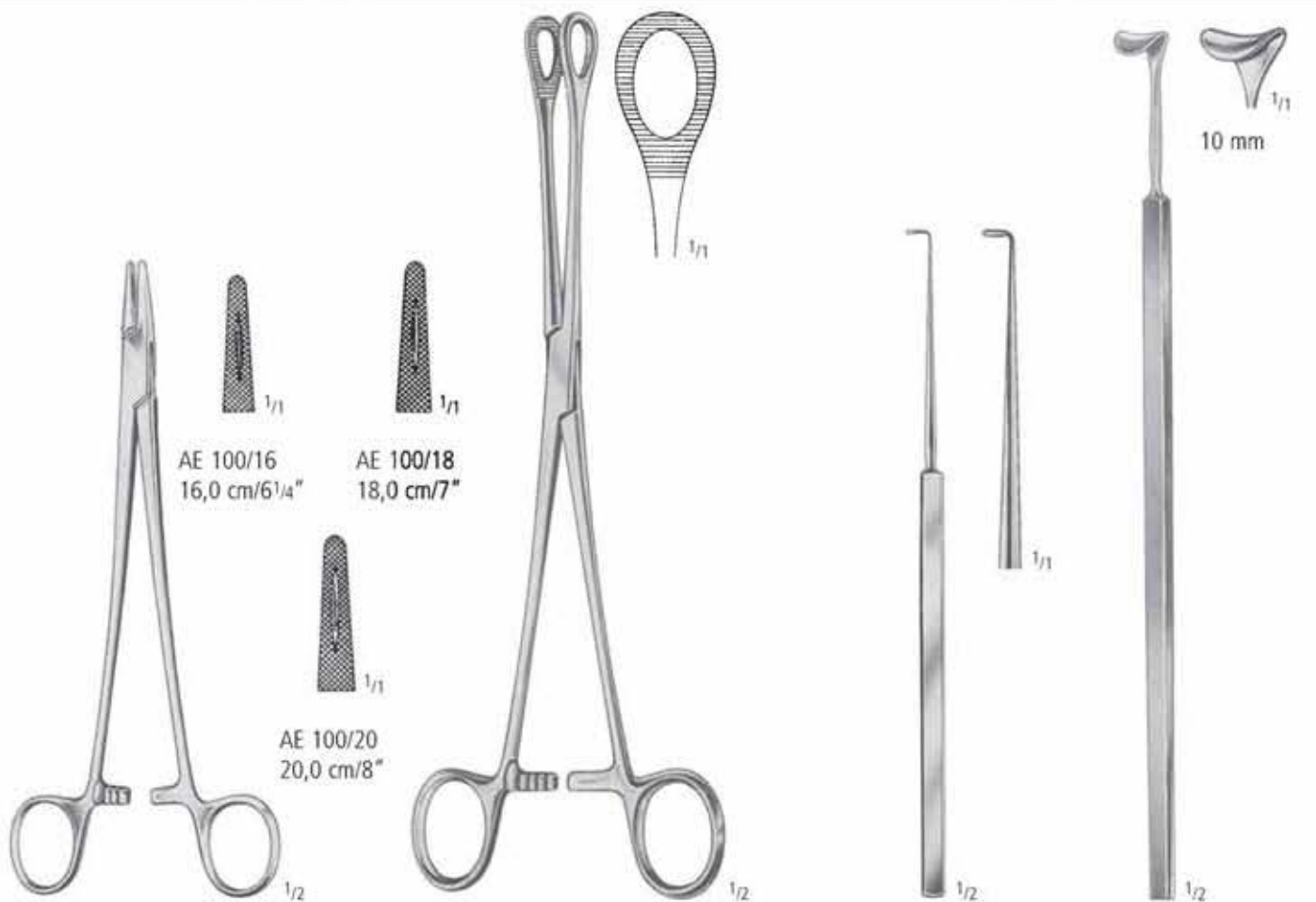

**MAYO-HEGAR**

**FOERSTER-BALLENGER**

**CUSHING**

**CUSHING**

AF 200/25  
25,0 cm/10"

AK 036/01  
19,0 cm/7 1/2"

AK 102/10  
24,0 cm/9 1/2"

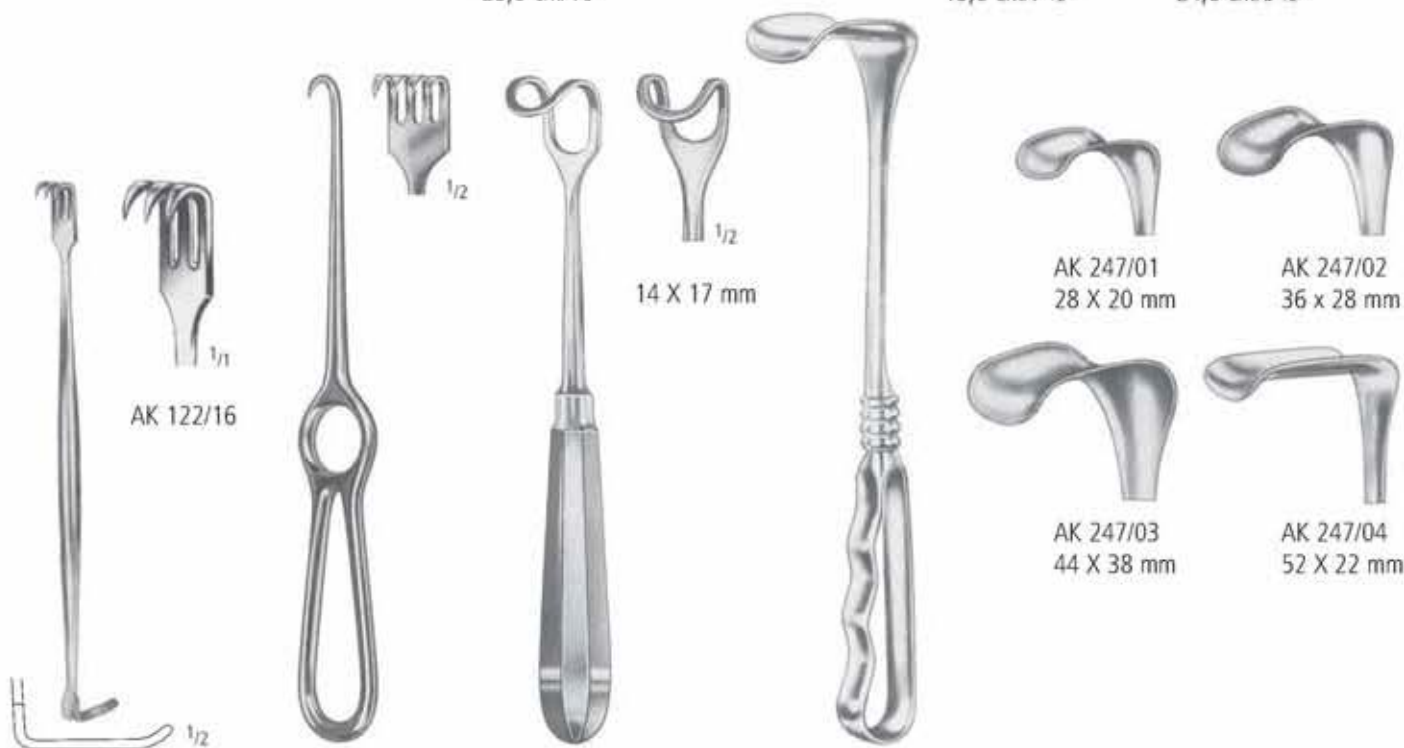

**SENN-MILLER**

**VOLKMANN**

**MIDDELDORPF**

**RICHARDSON (KELLY)**

AK 122/16  
16,0 cm/6 1/4"

AK 150/04  
21,5 cm/8 1/2"

AK 245/17  
21,5 cm/8 1/2"

24,0 cm/9 1/2"



**DEAVER**  
AK 300/04  
30,0 cm/12"



**DEAVER**  
AK 300/08  
30,0 cm/12"



**DEAVER**  
AK 300/09  
30,0 cm/12"

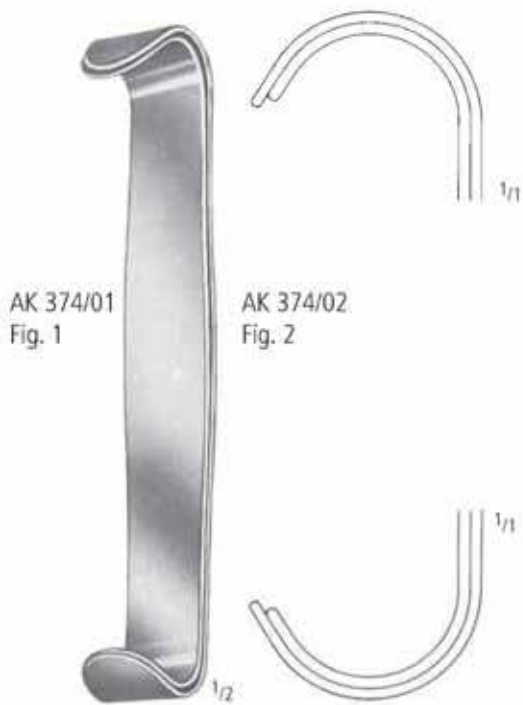

**PARKER**  
AK 374/00 Fig. 1+2  
18,0 cm/7"

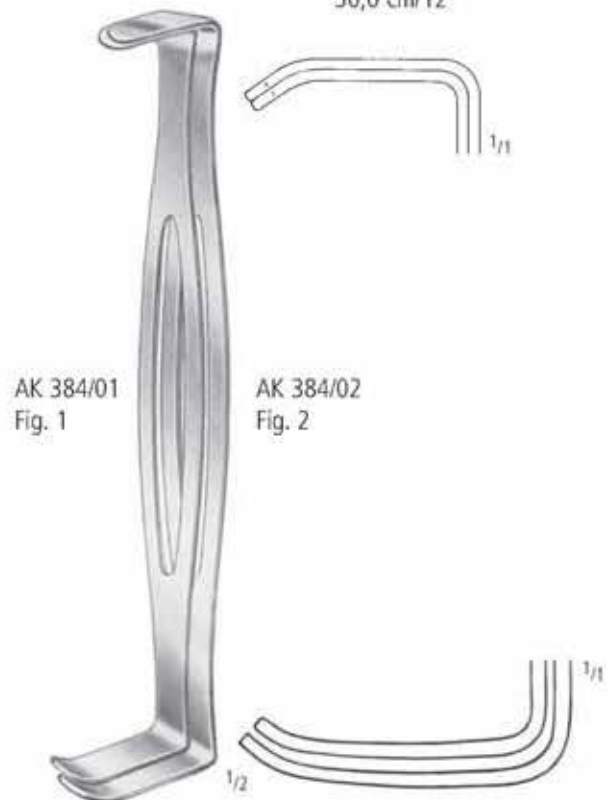

**PARKER-LANGENBECK (U.S. Army)**  
AK 384/00 Fig. 1+2  
21,0 cm/8<sup>1</sup>/<sub>4</sub>"





**WEITLANER**  
13,0 cm/5" AK 520/13



**GELPI**  
AK 580/19  
19,0 cm/7 1/2"



biegsam  
malleable  
maleables  
malleables  
malleabili

33,0 cm/13"  
30 mm AK 804/30  
40 mm AK 804/40  
50 mm AK 804/50



**YANKAUER**  
AO 400/00  
27,0 cm/11"



**WALTON-YANKAUER**  
AO 404/00  
32,5 cm/13"



**POOLE**  
AO 421/22  
8,0 mm



**FRAZIER**  
10 Charr. AO 430/10



KA 520/40  
 Ø 30 mm  
 400 g (14<sup>1</sup>/<sub>4</sub> oz.)

1/2

**WILLIGER**  
 24,0 cm/9<sup>1</sup>/<sub>2</sub>"



1/11

**ALLIS 5:6**  
 15,0 cm/6" KD 055/15  
 19,0 cm/7<sup>1</sup>/<sub>2</sub>" KD 055/19



1/11

**ALLIS-ADAIR 10:11**  
 KD 060/15  
 15,0 cm/6"



1/11

**BABCOCK**  
 KD 111/16  
 16,0 cm/6<sup>1</sup>/<sub>4</sub>"



1/3

**LEBSCHE**  
 KK 040/25  
 25,0 cm/10"



L(mm)	B(mm)	H(mm)	
540	255	70	KYE 301/07

---

ENDARTERIEKTOMIE  
ENDARTERECTOMY  
ENDARTERECTOMIA  
ENDARTERECTOMIE  
ENDATERECTOMIA

**SET**

ZS 941/70

Siebvorschlag - Suggested instrument set



ZS 941/70	Contents:	Qty
AA 151/12	HALSTED-MOSQUITO FCPS CVD 12,5 CM	12
AA 181/14	CRILE FORCEPS CURVED 14,0 CM	12
AA 201/16	ROCHESTER-PEAN FCPS CVD 16,0 CM	6
AA 348/18	BABY-MIXTER ART. FCPS CVD 18,0 CM	2
AA 751/13	BACKHAUS TOWEL FORCEPS 13,0 CM	6
AB 050/14	STANDARD DRESSING FORCEPS STR 14,5 CM	2
AB 060/14	STANDARD TISSUE FCPS. 1X2 TEETH STR 14,5 CM	2
AB 100/12	ADSON DRESSING FORCEPS 12,0 CM	2
AB 110/12	ADSON TISSUE FCPS 1X2 TEETH 12,0 CM	2
AC 072/17	MAYO-STILLE OPER. SCS STR BL/BL 17,0 CM	1
AC 073/17	MAYO-STILLE OPER. SCS CVD BL/BL 17,0 CM	1
AC 111/18	METZENBAUM-NELSON SCS CVD BL/BL 18,0 CM	1
AC 219/45	POTTS-SMITH ART. SCS 45 DEGREE 19,0 CM	1
AC 450/11	IRIS SCISSORS STR SH/SH 11,5 CM	1
AC 451/11	IRIS SCISSORS CVD SH/SH 11,5 CM	1
AD 010/03	SCALPEL HANDLE NO. 3	1
AE 070/15	CRILE-WOOD NEEDLE HOLDER 15,0 CM	2
AF 200/25	FOERSTER-BALLENGER STR SERRATED 25,0 CM	4
AK 036/01	CUSHING DELICATE HOOK FIG.1 19,0 CM	2
AK 245/22	MIDDELDORPF RETRACTOR 20X22 MM 22,0 CM	2
AK 247/01	RICHARDSON RETRACTOR 28X20 MM 24,0 CM	2
AK 384/00	PARKER-LANGENBECK US-ARMY SET FIG.1+2	1
AL 003/13	PROBE W. EYE 13,0 CM 2 MM	2
AO 430/10	FRAZIER BRAIN SUCTION TUBE CHARR10/17,0 CM	2
KD 055/15	ALLIS FCPS 5X6 T 15,0 CM	4
KK 371/06	GLOVER ATRAUMA-BULLDOG CLAMP CVD 5,5 CM	2
KK 371/07	GLOVER ATRAUMA-BULLDOG CLAMP CVD 6,5 CM	2
KK 371/09	GLOVER ATRAUMA-BULLDOG CLAMP CVD 8,5 CM	2
KS 638/01	PENFIELD DURA DISSECTORS FIG.1 17,5 CM	1
KYE 301/07	WIRE BASKET, 540 X 255 X 70 MM	1

Sterilization Container KYE 200/51, if required.

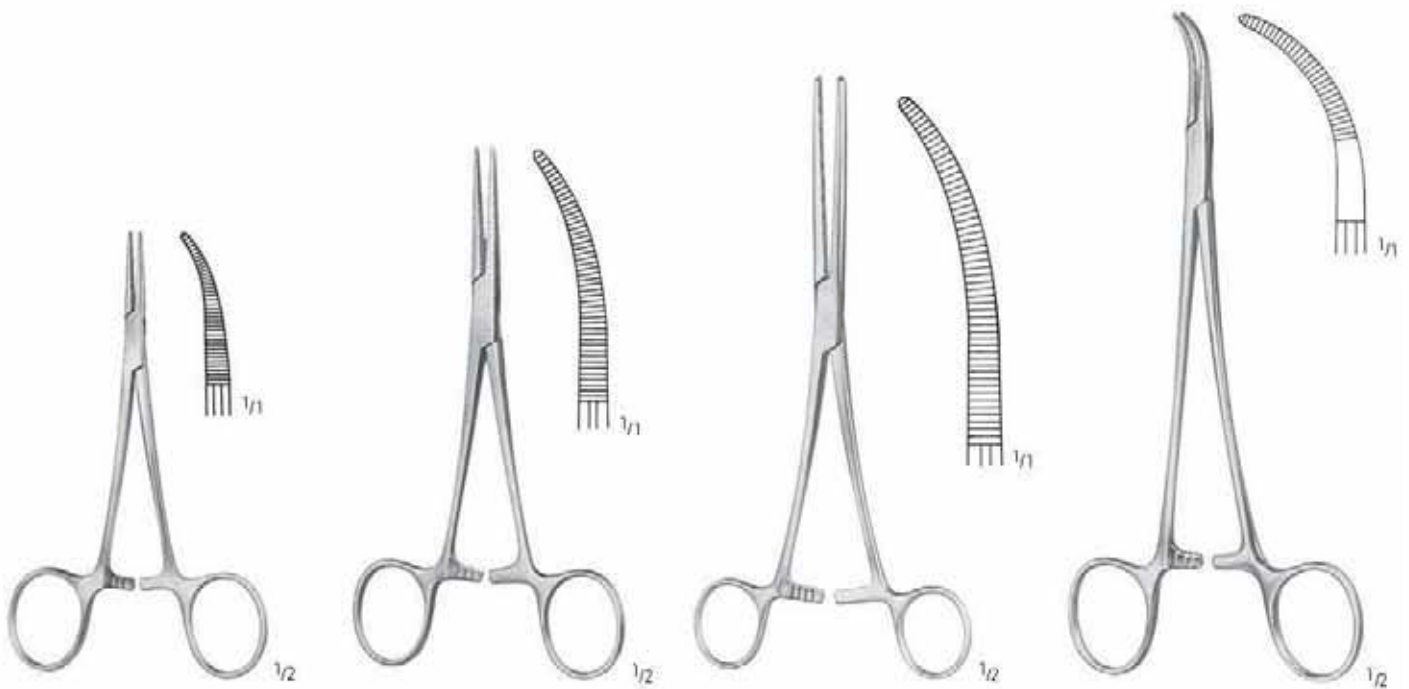

**HALSTED-MOSQUITO**  
AA 151/12  
12,5 cm/5"

**CRILE**  
AA 181/14  
14,0 cm/5½"

**ROCHESTER-PEAN**  
AA 201/16  
16,0 cm/6¼"

**BABY-MIXTER**  
AA 348/18  
18,0 cm/7"

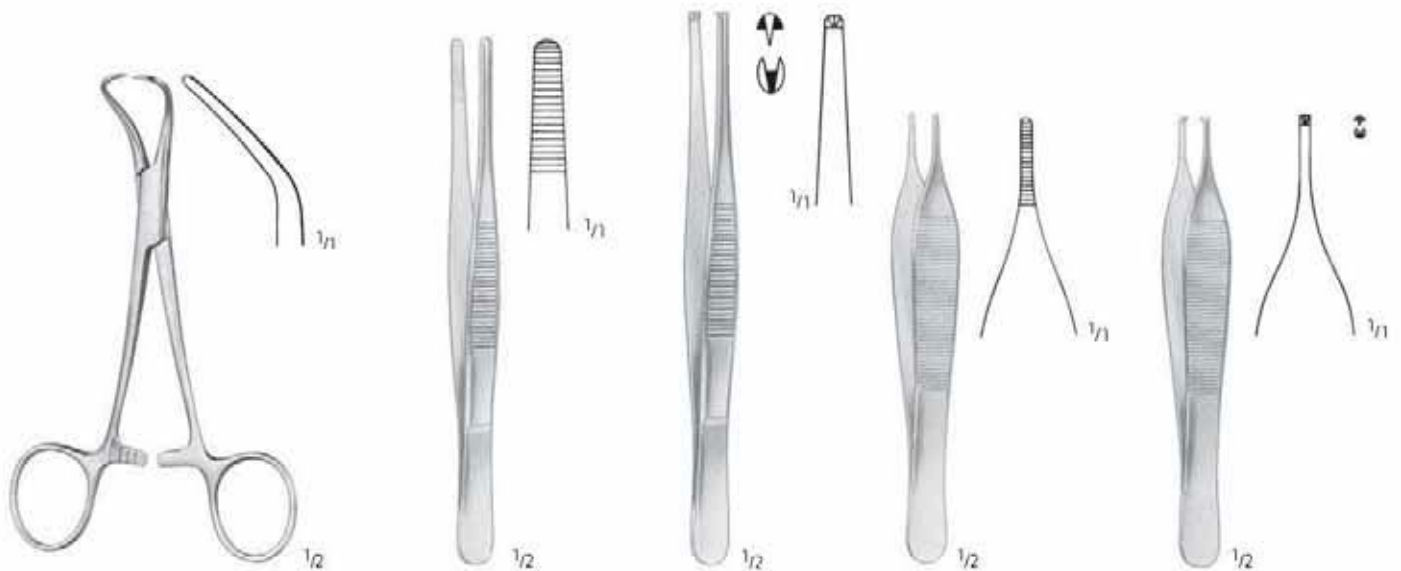

**BACKHAUS**  
AA 751/13  
13,0 cm/5"

**STANDARD**  
AB 050/14  
14,0 cm/5½"

**STANDARD 1:2**  
AB 060/14  
14,5 cm/5¾"

**ADSON**  
AB 100/12  
12,0 cm/4¾"

**ADSON 1:2**  
AB 110/12  
12,0 cm/4¾"

cardiovascular basic

endarterectomy

thoracotomy

coronary bypass



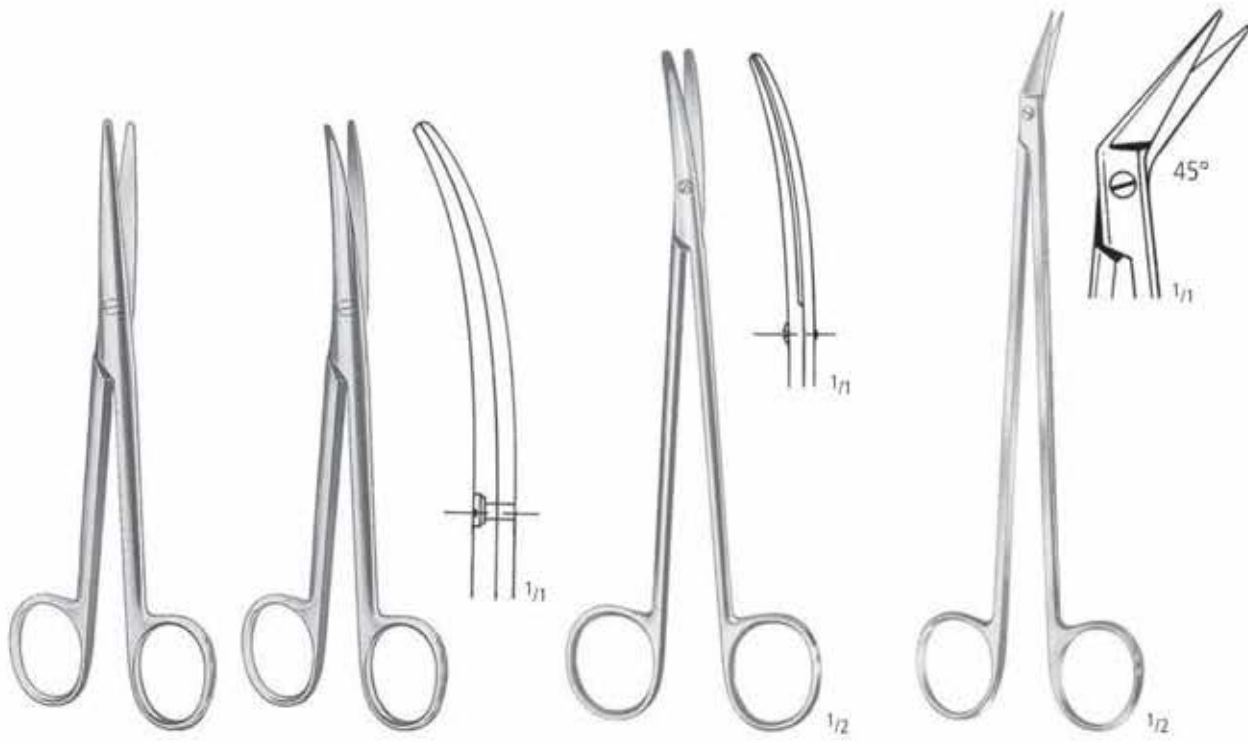

**MAYO-STILLE**  
AC 072/17  
17,0 cm/6<sup>1</sup>/<sub>4</sub>"

**MAYO-STILLE**  
AC 073/17  
17,0 cm/6<sup>1</sup>/<sub>4</sub>"

**METZENBAUM-NELSON**  
AC 111/18  
18,0 cm/7"

**POTTS-SMITH**  
AC 219/45  
19,0 cm/7<sup>1</sup>/<sub>2</sub>"

Irisscheren  
Iris Scissors  
Tijeras para iridectomia  
Ciseaux à iridectomie  
Forbici per iridectomia



AC 450/11  
11,5 cm/4<sup>1</sup>/<sub>2</sub>"

AC 451/11  
11,5 cm/4<sup>1</sup>/<sub>2</sub>"

AD 010/03  
No. 3

**CRILE-WOOD**  
AE 070/15  
15,0 cm/6"

**FOERSTER-BALLENGER**  
AF 200/25  
25,0 cm/10"



**CUSHING**  
AK 036/01  
19,0 cm/7 1/2"



**MIDDELDORPF**  
AK 245/22  
22,0 cm/8 3/4"



**RICHARDSON (KELLY)**  
AK 247/01  
24,0 cm/9 1/2"



**PARKER-LANGENBECK (U.S. Army)**  
AK 384/00 Fig. 1+2  
21,0 cm/8 1/4"



**AL 003/13**  
13,0 cm/5"



**FRAZIER**  
10 Charr. AO 430/10



**ALLIS 5:6**  
KD 055/15  
15,0 cm/6"



**GLOVER**

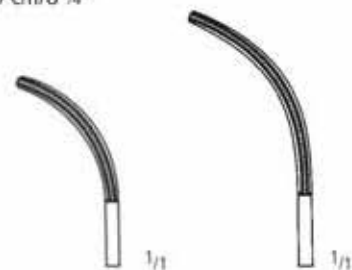

**KK 371/06**  
5,5 cm/2 1/4"

**KK 371/07**  
6,5 cm/2 1/2"



**KK 371/09**  
8,5 cm/3 1/3"

cardiovascular basic

endarterectomy

thoracotomy

coronary bypass



**PENFIELD**  
KS 638/01  
17,5 cm/7"



L(mm)	B(mm)	H(mm)	
540	255	70	KYE 301/07



---

THORAKOTOMIE  
THORACOTOMY  
THORACOTOMIA  
THORACOTOMIE  
THORACOTOMIA

**SET**

ZS 941/01

Siebvorschlag - Suggested instrument set



## THORAKOTOMIE THORACOTOMY THORACOTOMIA THORACOTOMIE THORACOTOMIA

ZS 941/01	Contents:	Qty
AA 151/12	HALSTED-MOSQUITO FCPS CVD 12,5 CM	12
AA 201/16	ROCHESTER-PEAN FCPS CVD 16,0 CM	12
AA 355/23	MIXTER FORCEPS CVD 23,0 CM	2
AA 751/08	BACKHAUS TOWEL FORCEPS 8,0 CM	12
AB 200/25	POTTS-SMITH DRESSING FORCEPS STR 25,0 CM	2
AB 210/25	POTTS-SMITH TISS. FCPS STR 1X2 TEETH 25,0 CM	1
AB 418/23	NELSON GRASPING FCPS 23,0 CM	1
AC 111/28	METZENBAUM-NELSON SCS CVD BL/BL 28,0 CM	1
AE 130/27	MASSON NEEDLE HOLDER 27,0 CM	1
AK 150/04	VOLKMANN RETR. SHARP 4 PRONGS 21,5 CM	2
AK 230/02	LANGENBECK RETRACTOR 22,0 CM 30X14 MM	2
AK 337/90	DAVIDSON RETRACTOR 75X90 MM 16,0 CM	1
KA 550/53	MALLET 530G STEEL SOLID Ø 42/30 MM 24,0 CM	1
KA 677/15	LAMBOTTE RASPATORIES 15 MM	1
KA 681/17	DOYEN PERIOST. RASPATORY CVD LEFT 17,0 CM	1
KA 683/17	DOYEN PERIOST. RASPATORY CVD RIGHT 17,0 CM	1
KA 763/19	SEMB BONE HOLDING FCPS W/O RATCHET 19,0 CM	1
KA 853/22	STILLE-LUER BONE RONGEURS CVD 22,0 CM	1
KD 124/23	DUVAL INT. TISSUE FCPS LARGE 23,0 CM	2
KK 018/34	BETHUNE RIB SHEARS 34,0 CM	1
KK 040/25	LEBSCHER CHISEL 25,0 CM	1
KK 092/02	FINOCCHIETTO RIB SPREADER 46X62X190 MM	1
KK 170/19	SELLORS RIB CONTRACTOR 19,0 CM	1
KK 180/32	ALLISON LUNG SPATULA 32,0 CM	1
KK 701/22	PRICE-THOMAS FORCEPS 22,0 CM	1
KK 703/02	SEMB BRONCHUS CLAMPS 22,0 CM	1
KYE 301/07	WIRE BASKET, 540 X 255 X 70 MM	1

Sterilization Container KYE 200/51, if required.

THORAKOTOMIE THORACOTOMY THORACOTOMIA THORACOTOMIE THORACOTOMIA



**HALSTED-MOSQUITO**  
AA 151/12  
12,5 cm/5"

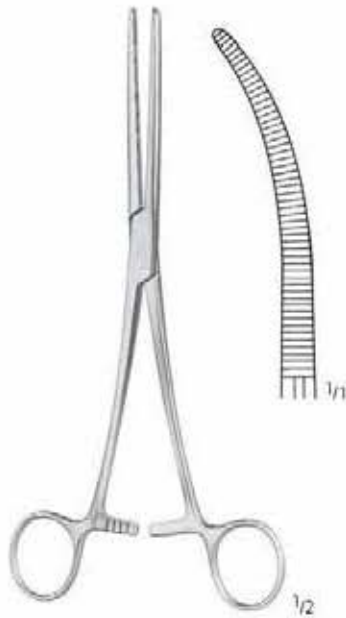

**ROCHESTER-PEAN**  
AA 201/16  
16,0 cm/6 1/4"



**MIXTER**  
AA 355/23  
23,0 cm/9"

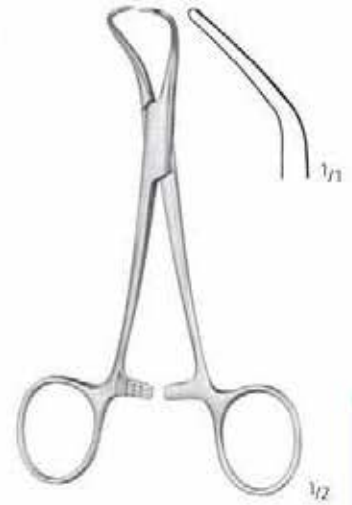

**BACKHAUS**  
AA 751/08  
8,0 cm/3"



**POTTS-SMITH**  
AB 200/25  
25,0 cm/10"



**POTTS-SMITH 1:2**  
AB 210/25  
25,0 cm/10"



**NELSON**  
AB 418/23  
23,0 cm/9"



**METZENBAUM-NELSON**  
AC 111/28  
28,0 cm/11"



**MASSON**  
AE 130/27  
27,0 cm/10 3/4"

cardiovascular basic

endarterectomy

thoracotomy

coronary bypass



**VOLKMANN**  
AK 150/04  
21,5 cm/8<sup>1</sup>/<sub>2</sub>"



**LANGENBECK**  
AK 230/02  
22,0 cm/8<sup>3</sup>/<sub>4</sub>"



**DAVIDSON**  
AK 337/90  
16,0 cm/6<sup>1</sup>/<sub>4</sub>"



Ø 42 mm      Ø 30 mm  
530 g  
(19 oz.)

KA 550/53  
24,0 cm/9<sup>1</sup>/<sub>2</sub>"



**LAMBOTTE**  
KA 677/15  
21,0 cm/8<sup>1</sup>/<sub>4</sub>"



**DOYEN**  
17,0 cm/6<sup>3</sup>/<sub>4</sub>"

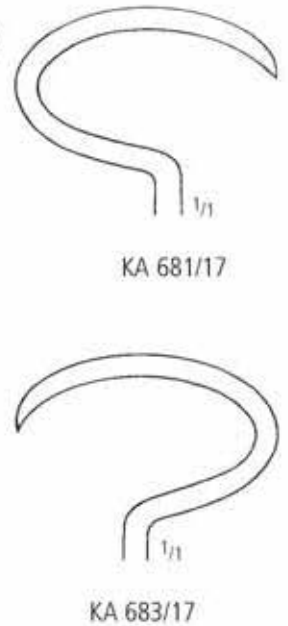

KA 681/17

KA 683/17

THORAKOTOMIE THORACOTOMY THORACOTOMIA THORACOTOMIE THORACOTOMIA



**SEMB**  
KA 763/19  
19,0 cm/7<sup>1</sup>/<sub>2</sub>"

**STILLE-LUER**  
KA 853/22  
22,0 cm/8<sup>3</sup>/<sub>4</sub>"

**DUVAL**  
KD 124/23  
23,0 cm/9"

**BETHUNE**  
KK 018/34  
34,0 cm/13<sup>1</sup>/<sub>2</sub>"



**LEBSCH**  
KK 040/25  
25,0 cm/10"

**B** 46 mm    **H** 62 mm    **C** 190 mm

**FINOCCHIETTO**  
KK 092/02

**SELLORS**  
KK 170/19  
19,0 cm/7<sup>1</sup>/<sub>2</sub>"

cardiovascular basic

endarterectomy

thoracotomy

coronary bypass





1/2

**ALLISON**  
KK 180/32  
32,0 cm/12<sup>1</sup>/<sub>2</sub>"



1/2

**PRICE-THOMAS**  
KK 701/22  
22,0 cm/8<sup>3</sup>/<sub>4</sub>"

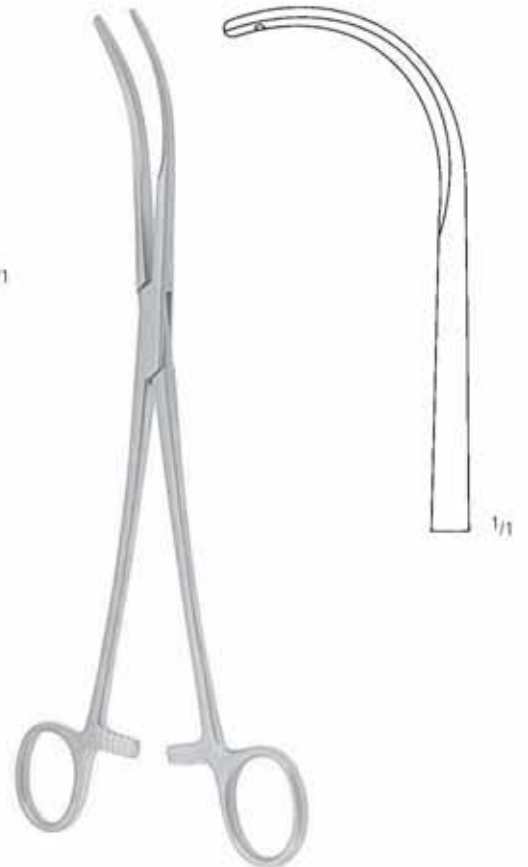

1/1

**SEMB**  
KK 703/02  
24,0 cm/9<sup>1</sup>/<sub>2</sub>"



L(mm)	B(mm)	H(mm)	
540	255	70	KYE 301/07

---

KORONAR ARTERIEN-BYPASS  
CORONARY BYPASS  
BYPASS CORONARIO  
PONTAGE AORTO-CORONARIEN  
BYPASS AORTO-CORONARICO

**SET**

ZS 941/60

Siebvorschlag - Suggested instrument set



**ZS 941/60**

Contents:

Qty

AA 114/10	HARTMANN FORCEPS STR 10,0 CM	6
AA 115/10	HARTMANN FORCEPS CVD 10,0 CM	6
AA 347/19	MIXTER-O'SHAUGNESSY ART. FCPS CVD 19,0 CM	2
AB 860/16	DE BAKEY ATRAUMA FCPS STR 1,5 MM 16,0 CM	2
AB 860/20	DE BAKEY ATRAUMA FCPS STR 1.5 MM 20,0 CM	2
AB 860/24	DE BAKEY ATRAUMA FCPS STR 1.5 MM 24,0 CM	2
AC 214/15	REYNOLDS DISS. SCISSORS STR SHARP 15,0 CM	1
AC 224/01	HEGEMANN-DIETRICH VASC. SCS 25 DEG 19,0 CM	1
AC 224/02	HEGEMANN-DIETRICH VASC. SCS 45 DEG 19,0 CM	1
AC 224/03	HEGEMANN-DIETRICH VASC. SCS 60 DEG 19,0 CM	1
AC 224/04	HEGEMANN-DIETRICH VASC. SCS 90 DEG 19,0 CM	1
AC 224/05	HEGEMANN-DIETRICH VASC. SCS 125 DEG 19,0 CM	1
AE 430/15	RYDER/FRENCH-EYE NEEDLE HOLDER TUC 15,0 CM	1
AE 430/18	RYDER/FRENCH-EYE NEEDLE HOLDER TUC 18,0 CM	1
AE 434/15	MICRO RYDER NEEDLE HOLDER TUC 15,0 CM	1
KC 130/01	BAKES GALL DUCT DILATOR FIG.1 30,0 CM	1
KC 130/02	BAKES GALL DUCT DILATOR FIG.2 30,0 CM	1
KC 130/03	BAKES GALL DUCT DILATOR FIG.3 30,0 CM	1
KC 130/04	BAKES GALL DUCT DILATOR FIG.4 30,0 CM	1
KC 130/05	BAKES GALL DUCT DILATOR FIG.5 30,0 CM	1
KC 130/06	BAKES GALL DUCT DILATOR FIG.6 30,0 CM	1
KC 130/07	BAKES GALL DUCT DILATOR FIG.7 30,0 CM	1
KC 130/08	BAKES GALL DUCT DILATOR FIG.8 30,0 CM	1
KC 130/09	BAKES GALL DUCT DILATOR FIG.9 30,0 CM	1
KC 130/10	BAKES GALL DUCT DILATOR FIG.10 30,0 CM	1
KC 130/11	BAKES GALL DUCT DILATOR FIG.11 30,0 CM	1
KK 453/20	DE BAKEY FORCEPS 20,0 CM	1
KYE 301/07	WIRE BASKET, 540 x 255 x 70 MM	1

Sterilization Container KYE 200/51, if required.





**HARTMANN**  
AA 114/10  
10,0 cm/4"



**HARTMANN**  
AA 115/10  
10,0 cm/4"

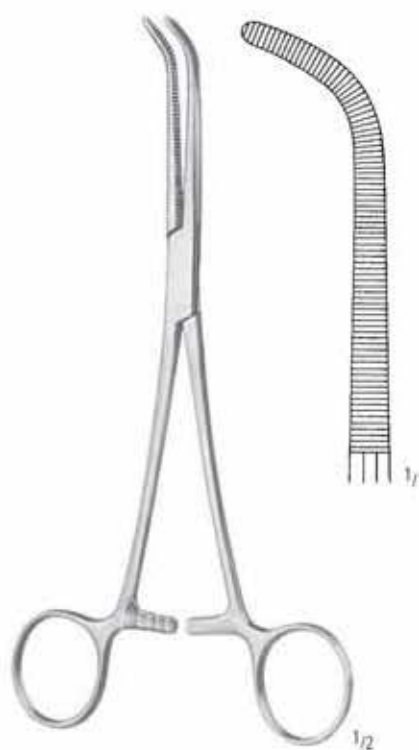

**MIXTER-O'SHAUGHNESSY**  
AA 347/19  
19,0 cm/7 1/2"

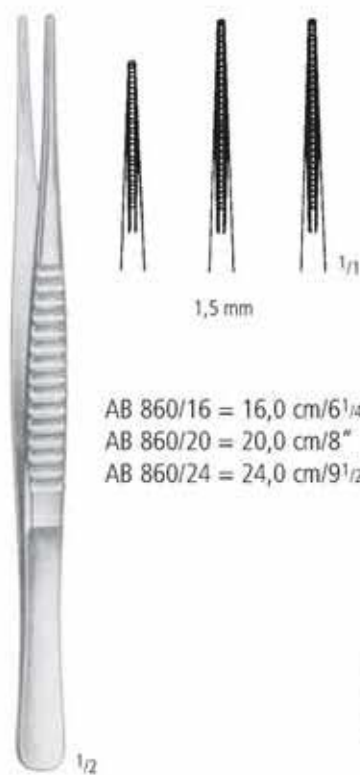

AB 860/16 = 16,0 cm/6 1/4"  
AB 860/20 = 20,0 cm/8"  
AB 860/24 = 24,0 cm/9 1/2"

**DE BAKY**



**REYNOLDS**  
AC 214/15  
15,0 cm/6"

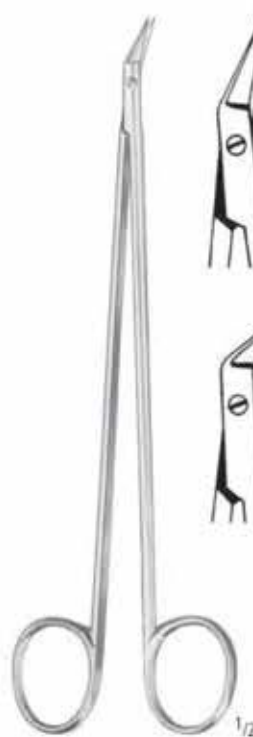

**HEGEMANN-DIETRICH**  
19,0 cm/7 1/2"

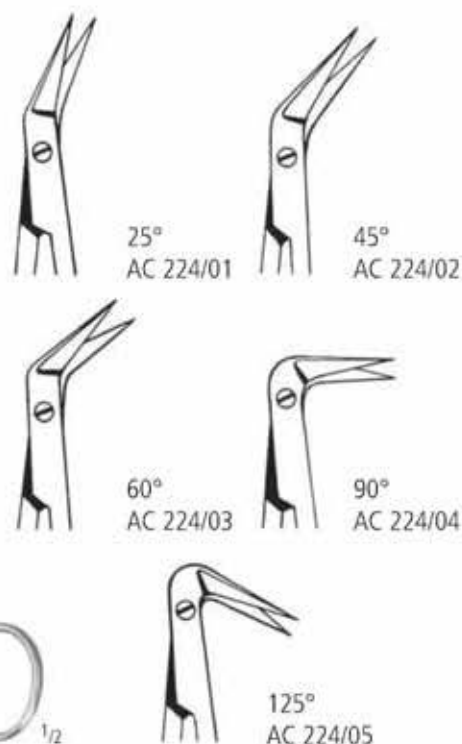

cardiovascular basic

endarterectomy

thoracotomy

coronary bypass

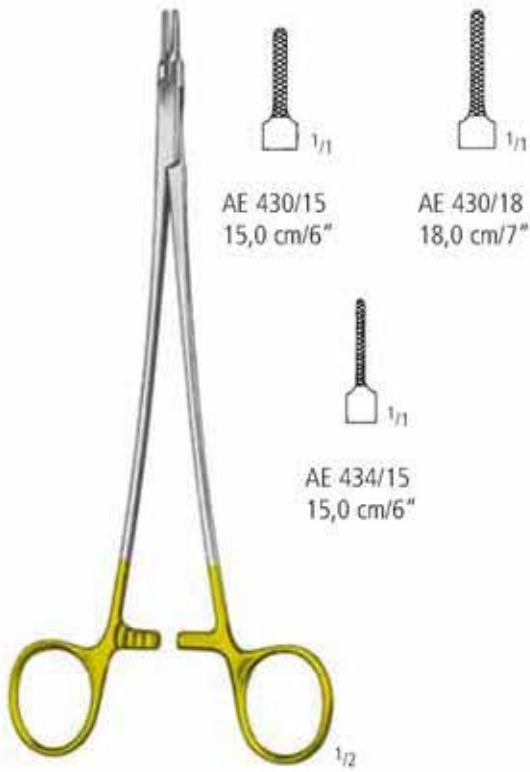

**RYDER/FRENCH-EYE**



**DE BAKEY**



**BAKES**  
30,0 cm/12"

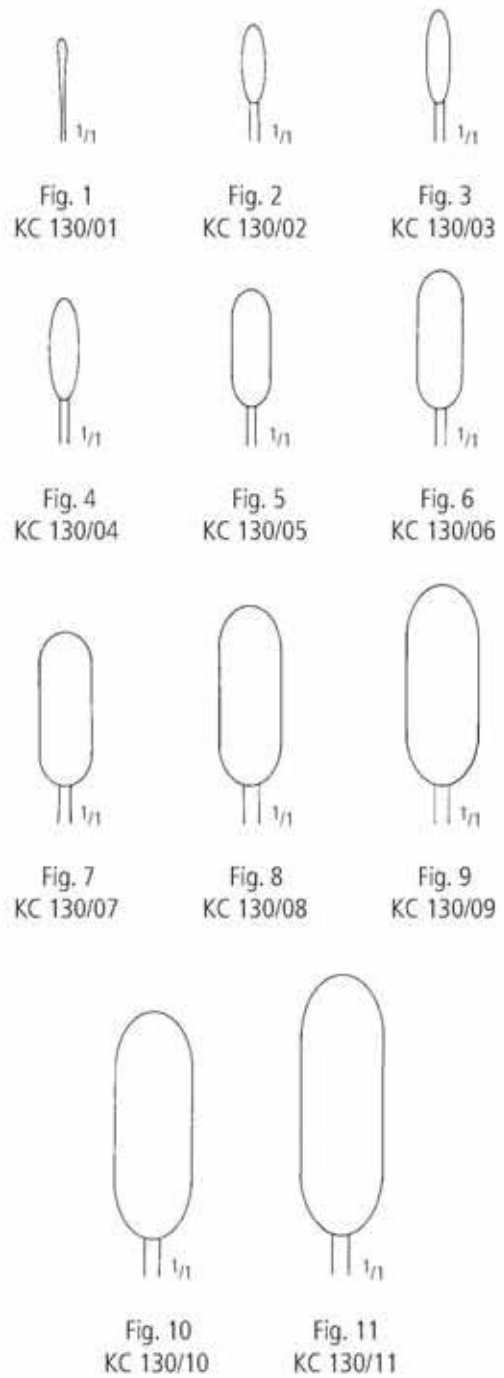

L(mm)	B(mm)	H(mm)	
540	255	70	KYE 301/07

KLEMMEN  
HEMOSTATS  
PINZAS HEMOSTATICAS  
PINCES HEMOSTATIQUES  
PINZE EMOSTATICHE

AA

nopa<sup>®</sup> instruments

Weitere Klemmen finden Sie in unserem Katalog „Allgemeine Chirurgie“ in Gruppe AA.

For further hemostats kindly refer to our catalogue "General Surgery", section AA.

Para pinzas hemostaticas adicionales, por favor consulte nuestro catálogo de "Cirugía general", grupo AA.

Pour des pinces hemostatiques supplémentaires, consultez notre catalogue „Chirurgie Generale“, section AA.

Per gli altri pinze emostatiche, consultare il nostro catalogo "Chirurgia Generale", gruppo AA.







titan instruments

# nopa<sup>®</sup> instruments

## Besonderheit:

nopa Titan Instrumente bieten insbesondere in der Herz-Thorax-Chirurgie Vorteile gegenüber herkömmlichen Instrumenten. Titan ist ca. 45% leichter als rostfreier Edelstahl, weshalb Titan Instrumente weniger traumatisierend sind. Titan ist außerdem ein vollkommen korrosionsbeständiges und antimagnetisches Material. nopa Titan Instrumente bedeuten größtmöglichen Komfort für den Chirurgen.

## Features:

nopa Titan Instruments provide especially in Cardiovascular surgery a significant advantage compared to other Instruments. Titan is approximately 45% lighter than stainless steel. For that reason, Titan Instruments are less traumatic. Besides that, Titan is a completely stainless and anti-magnetic material. nopa Titan Instruments are the most comfortable choice for the Cardiovascular surgeon.

AA 114/10 T	HARTMANN FORCEPS STR 10,0 CM
AA 115/10 T	HARTMANN FORCEPS CVD 10,0 CM
AA 130/12 T	MICRO-MOSQUITO FORCEPS STR 12,0 CM
AA 131/12 T	MICRO-MOSQUITO FORCEPS CVD 12,0 CM
AA 132/12 T	MICRO-MOSQUITO ARTERY FCPS 1X2 STR 12,0 CM
AA 133/12 T	MICRO-MOSQUITO ARTERY FCPS 1X2 CVD 12,0 CM
AA 150/12 T	HALSTED-MOSQUITO FORCEPS STR 12,5 CM
AA 151/12 T	HALSTED-MOSQUITO FORCEPS CVD 12,5 CM
AA 152/12 T	HALSTED-MOSQUITO ARTERY FCPS 1X2 STR 12,5 CM
AA 153/12 T	HALSTED-MOSQUITO FCPS 1X2 CVD 12,5 CM
AA 160/15 T	LERICHE ARTERY FCPS STR 15,0 CM
AA 161/15 T	LERICHE ARTERY CVD 15,0 CM
AA 162/15 T	LERICHE ARTERY FCPS STR 1X2 T 15,0 CM
AA 163/15 T	LERICHE ARTERY FCPS CVD 1X2 T 15,0 CM
AA 330/24 T	CRAFOORD ARTERY FORCEPS CVD 24,0 CM



Gewebefasszangchen  
Tissue Seizing Forceps  
Pinzas para coger tejidos  
Pinces pour saisir le tissu  
Pinze per afferrare tessuti

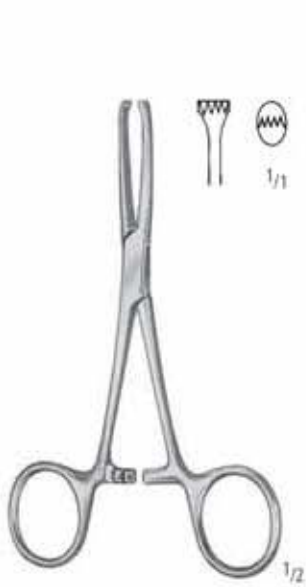

**ALLIS-BABY 4:5**  
KD 050/12  
12,5 cm/5"



**ALLIS 4:5**  
KD 054/15  
15,0 cm/6"



**ALLIS 5:6**  
15,0 cm/6"      KD 055/15  
19,0 cm/7 1/2"      KD 055/19  
25,0 cm/10"      KD 055/25



**ALLIS**

KD 058/16  
16,0 cm/6 1/4"

KD 058/20  
20,0 cm/8"

KD 058/25  
25,0 cm/10"

KD 058/30  
30,0 cm/12"



**ALLIS-ADAIR 10:11**  
KD 060/15  
15,0 cm/6"



Darmfazzangen  
Tissue Seizing Forceps  
Pinzas para coger intestinos  
Pincas pour saisir l'intestin  
Pinze per afferrare l'intestino



**BABCOCK**

16,0 cm/6 1/4" KD 100/16  
20,0 cm/8" KD 100/20



**BABCOCK**

KD 111/16  
16,0 cm/6 1/4"



KD 111/18  
18,0 cm/7"



KD 111/20  
20,0 cm/8"



KD 111/24  
24,0 cm/9 1/2"

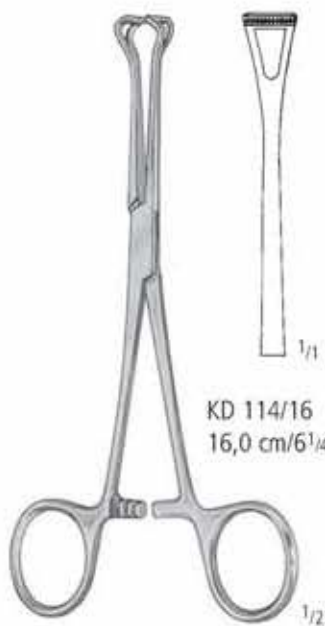

**BABCOCK**

KD 114/16  
16,0 cm/6 1/4"



KD 114/20  
20,0 cm/8"



**DUVAL**

KD 120/20  
20,0 cm/8"



KD 122/18  
18,0 cm/7"  
KD 122/20  
20,0 cm/8"

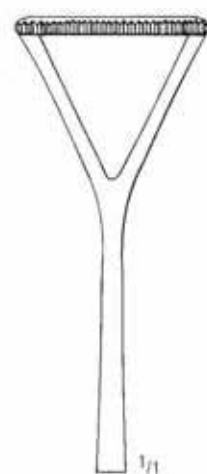

KD 124/20  
20,0 cm/8"  
KD 124/23  
23,0 cm/9"

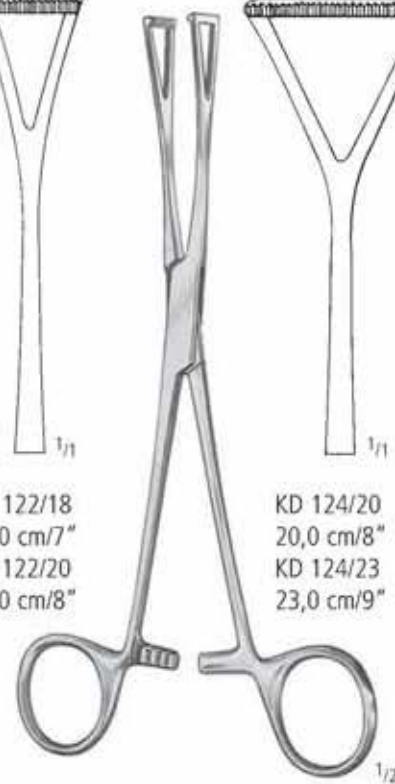

**DUVAL**

Bulldogklemmen  
Bulldog Clamps  
Clamps Bulldog  
Clamps Bulldog  
Pinze Bulldog

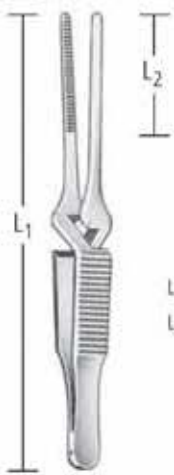

AA 050/01	AA 050/02	AA 050/03	AA 051/01	AA 051/02	AA 051/03
L <sub>1</sub> 50 mm	50 mm	60 mm	50 mm	50 mm	60 mm
L <sub>2</sub> 8 mm	12 mm	20 mm	8 mm	12 mm	20 mm

3 gr. Gewicht Weight Peso Poids Peso	50 gr. Druck Pressure Presión Pression Pressione
---	---

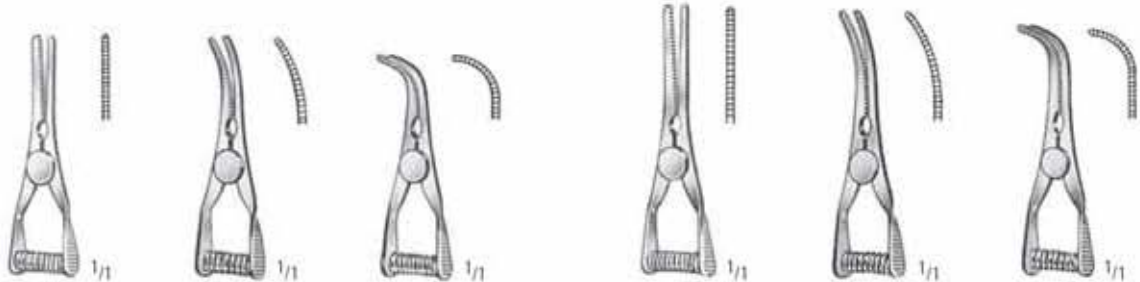

**VENA  
ARTERIA**

AA 052/01  
AA 053/01

**TITAN 30 mm**

AA 052/02  
AA 053/02

AA 052/03  
AA 053/03

AA 054/01  
AA 055/01

**TITAN 35 mm**

AA 054/02  
AA 055/02

AA 054/03  
AA 055/03

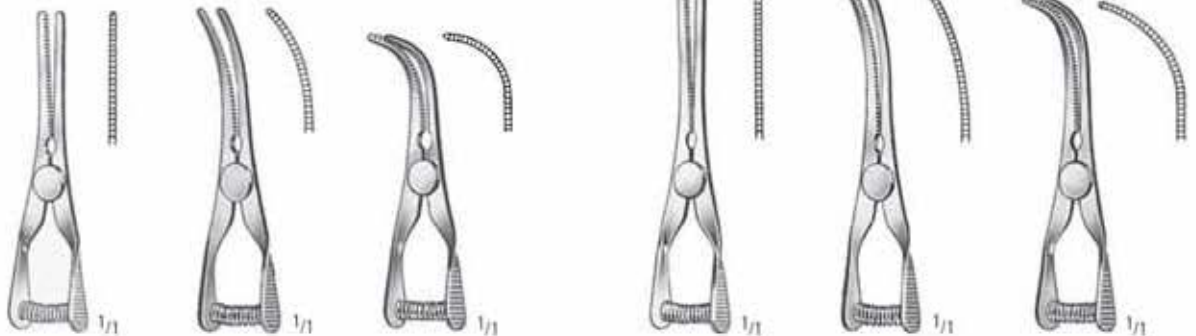

**VENA  
ARTERIA**

AA 056/01  
AA 057/01

**TITAN 40 mm**

AA 056/02  
AA 057/02

AA 056/03  
AA 057/03

AA 058/01  
AA 059/01

**TITAN 50 mm**

AA 058/02  
AA 059/02

AA 058/03  
AA 059/03



Bulldogklemmen, Anlegezange  
 Bulldog Clamps, Setting Forceps  
 Clamps Bulldog, Pinza para poner  
 Clamps Bulldog, Pince à poser  
 Pinze Bulldog, Pinza per posizionare



**DIEFFENBACH**



AA 060/03  
3,5 cm/1 1/2"



AA 060/05  
5,0 cm/2"

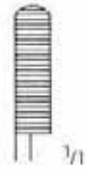

AA 060/06  
6,0 cm/2 1/2"



AA 061/03  
3,5 cm/1 1/2"



AA 061/05  
5,0 cm/2"



AA 061/06  
6,0 cm/2 1/2"



**JOHNS-HOPKINS**  
 AA 069/24  
 24,5 cm/9 3/4"



**JOHNS-HOPKINS**



AA 070/04  
4,0 cm/1 1/2"

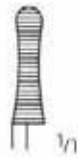

AA 070/05  
5,0 cm/2"



AA 070/06  
6,5 cm/2 1/2"



AA 070/07  
7,5 cm/3"

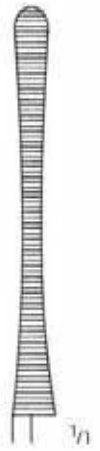

AA 070/09  
9,0 cm/3 1/2"



AA 071/04  
4,0 cm/1 1/2"



AA 071/05  
5,0 cm/2"

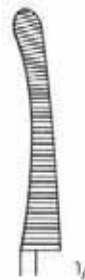

AA 071/06  
6,5 cm/2 1/2"



AA 071/07  
7,5 cm/3"



AA 071/09  
9,0 cm/3 1/2"

AA  
 AB  
 AC  
 AD  
 AE  
 AF  
 AK  
 AL  
 AO  
 KA  
 KK  
 X

Arterienklemmen  
 Artery Forceps  
 Pinzas hemostáticas  
 Pincas hémostatiques  
 Pinze emostatiche



**CHAPUT**  
 AA 072/02  
 13,0 cm/5"



**TUFFIER**  
 AA 072/04  
 13,0 cm/5"

Arterienklemmen  
 Artery forceps  
 Pinzas hemostáticas  
 Pincés hémostatiques  
 Pinze emostatiche

AA  
 AB  
 AC  
 AD  
 AE  
 AF  
 AK  
 AL  
 AO  
 KA  
 KK  
 X



AA 080/14



AA 080/16

**PEAN**  
 14,0 cm/5 1/2"  
 16,0 cm/6 1/4"



**KROENLEIN**  
 AA 082/13  
 13,0 cm/5"

Arterienklemmen  
 Artery Forceps  
 Pinzas hemostáticas  
 Pincas hémostáticas  
 Pinze emostatiche



**SPENCER-WELLS**

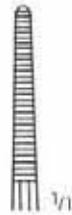

AA 110/13  
 13,0 cm/5"

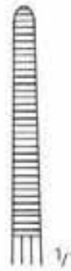

AA 110/14  
 14,0 cm/5 1/2"

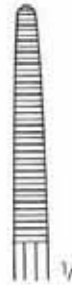

AA 110/15  
 15,5 cm/6"



AA 110/18  
 18,0 cm/7"

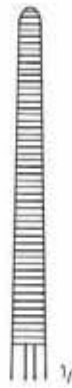

AA 110/20  
 20,0 cm/8"



AA 111/13  
 13,0 cm/5"



AA 111/14  
 14,0 cm/5 1/2"

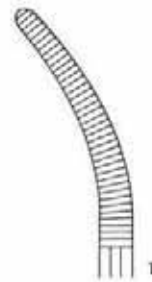

AA 111/15  
 15,5 cm/6"

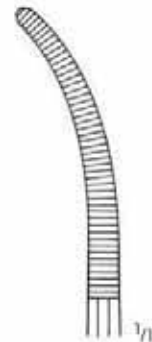

AA 111/18  
 18,0 cm/7"



AA 111/20  
 20,0 cm/8"



**HARTMANN**  
 AA 114/10  
 10,0 cm/4"



**HARTMANN**  
 AA 115/10  
 10,0 cm/4"

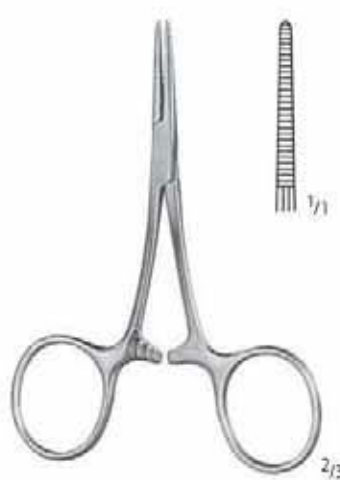

**CARREL**  
 AA 116/08  
 8,5 cm/3 1/2"



**TERRIER 1:2**  
 AA 118/08  
 8,5 cm/3 1/2"

Feine Arterienklemmen  
 Fine Artery Forceps  
 Pinzas hemostáticas finas  
 Pincas hémostatiques fines  
 Pinze emostatiche fine

AA

AB

AC

AD

AE

AF

AK

AL

AO

KA

KK

X

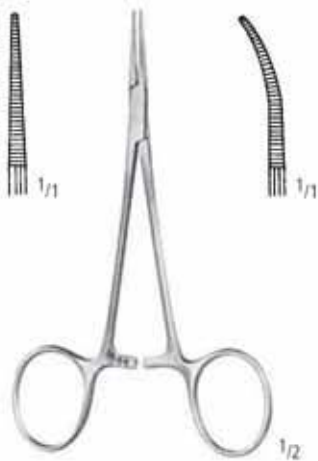

**MICRO-MOSQUITO**

AA 130/10      AA 131/10  
 AA 130/12      AA 131/12

10,0 cm/4"  
 12,0 cm/4<sup>3</sup>/<sub>4</sub>"



**MICRO-MOSQUITO 1:2**

AA 132/10      AA 133/10  
 AA 132/12      AA 133/12

**WILLIAM STEWART HALSTED**

was professor of surgery in the Johns Hopkins University. In 1890 he had bronze casts made of his own hands. On these casts the first surgical rubber gloves were moulded.



**HALSTED-MOSQUITO**

AA 150/12      AA 151/12  
 AA 150/14      AA 151/14

12,5 cm/5"  
 14,0 cm/5<sup>1</sup>/<sub>2</sub>"

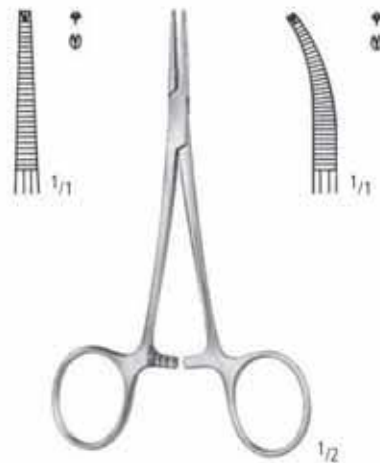

**HALSTED-MOSQUITO 1:2**

AA 152/12      AA 153/12  
 AA 152/14      AA 153/14



Arterienklemmen  
 Artery Forceps  
 Pinzas hemostáticas  
 Pincas hémostatiques  
 Pinze emostatiche

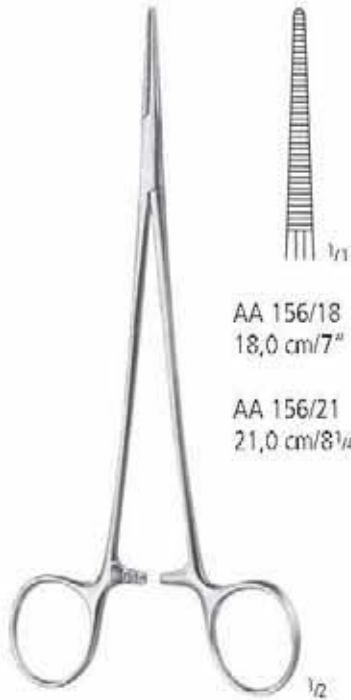

AA 156/18  
 18,0 cm/7"

AA 156/21  
 21,0 cm/8 1/4"

**HALSTED**



AA 157/18  
 18,0 cm/7"

AA 157/21  
 21,0 cm/8 1/4"



AA 158/18  
 18,0 cm/7"

AA 158/21  
 21,0 cm/8 1/4"

**HALSTED 1:2**



AA 159/18  
 18,0 cm/7"

AA 159/21  
 21,0 cm/8 1/4"

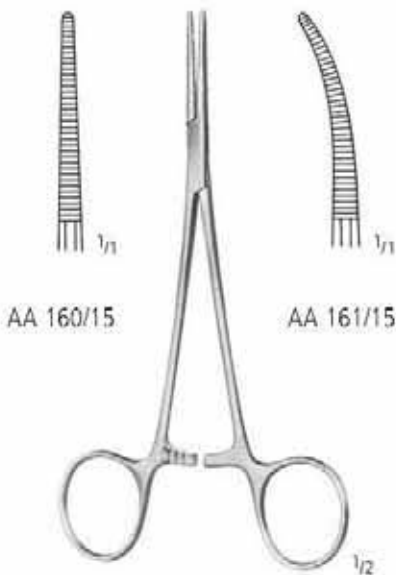

AA 160/15

AA 161/15

**LERICHE**  
 15,0 cm/6"

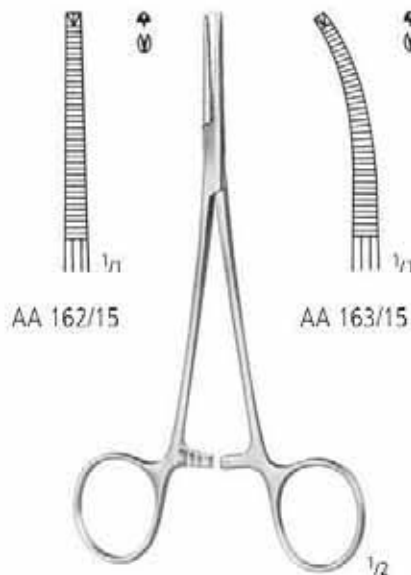

AA 162/15

AA 163/15

**LERICHE 1:2**  
 15,0 cm/6"

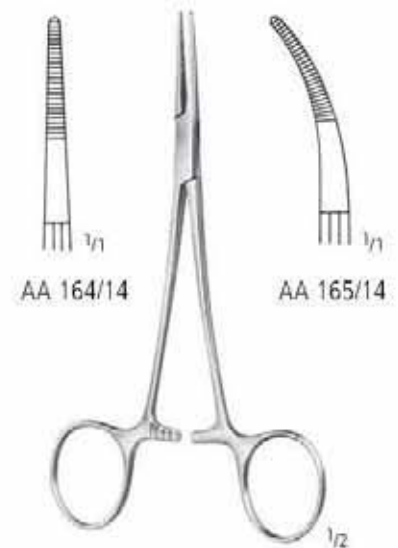

AA 164/14

AA 165/14

**PROVIDENCE-HOSPITAL**  
 14,0 cm/5 1/2"

Arterienklemmen  
 Artery forceps  
 Pinzas hemostáticas  
 Pincés hémostatiques  
 Pinze emostatiche

AA  
 AB  
 AC  
 AD  
 AE  
 AF  
 AG  
 AH  
 AI  
 AJ  
 AK  
 AL  
 AM  
 AN  
 AO  
 AP  
 AQ  
 AR  
 AS  
 AT  
 AU  
 AV  
 AW  
 AX

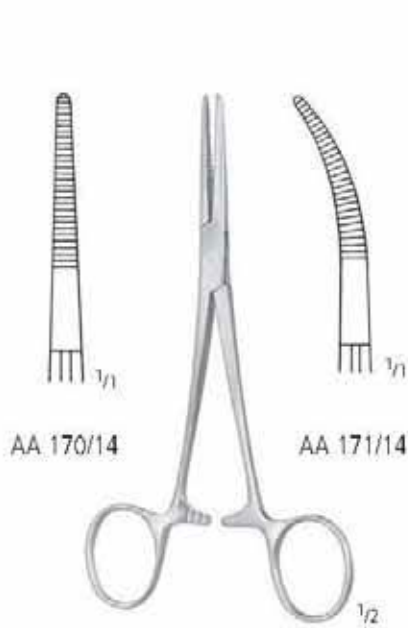

**KELLY**  
 14,0 cm/5 1/2"

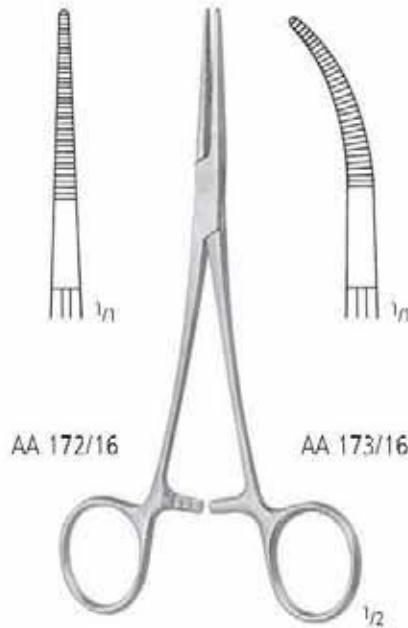

**KELLY-RANKIN**  
 16,0 cm/6 1/4"

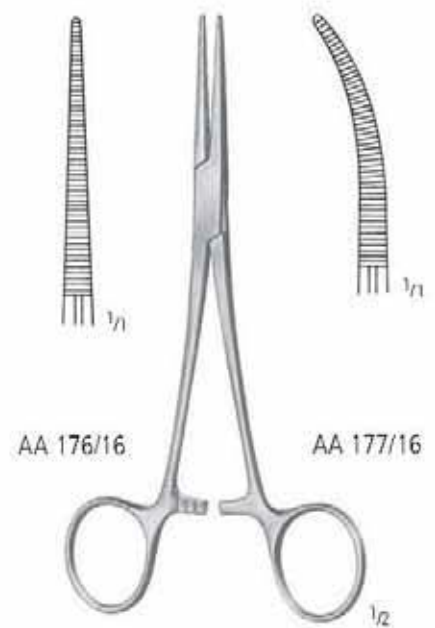

**COLLER**  
 AA 176/14 14,0 cm/5 1/2" AA 177/14  
 AA 176/16 16,0 cm/6 1/4" AA 177/16

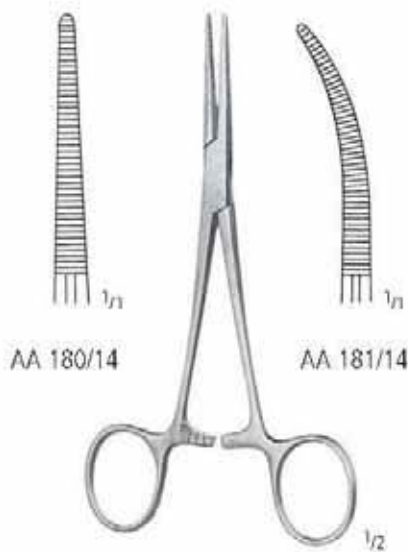

**CRILE**  
 14,0 cm/5 1/2"

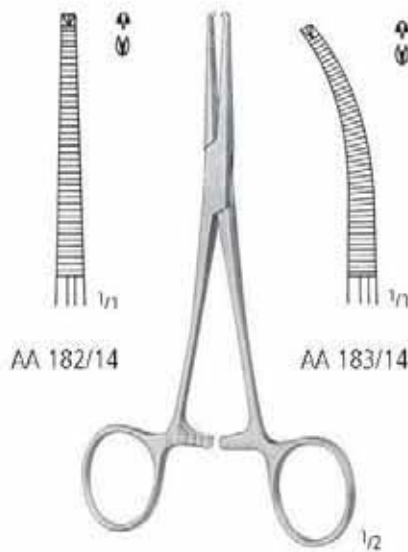

**CRILE 1:2**  
 14,0 cm/5 1/2"

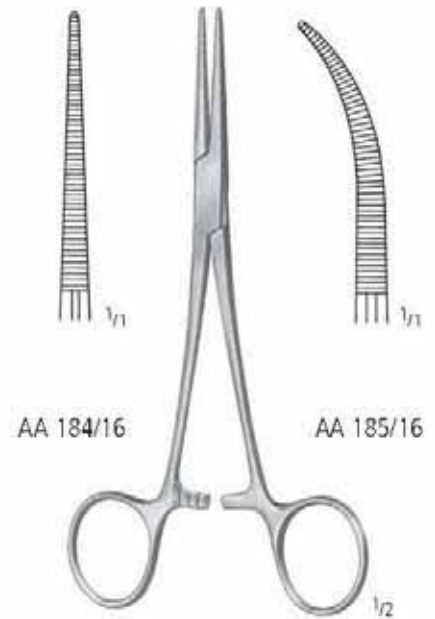

**CRILE-RANKIN**  
 16,0 cm/6 1/4"

Arterienklemmen  
 Artery Forceps  
 Pinzas hemostáticas  
 Pincès hémostatiques  
 Pinze emostatiche

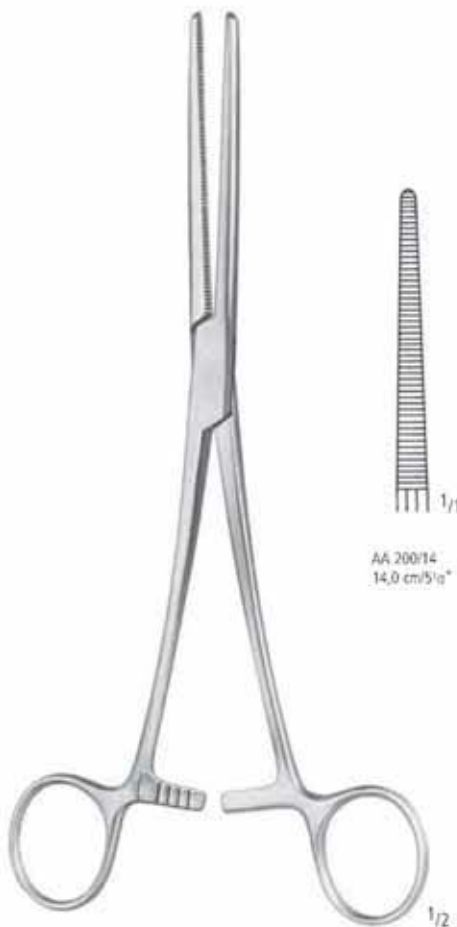

ROCHESTER-PEAN

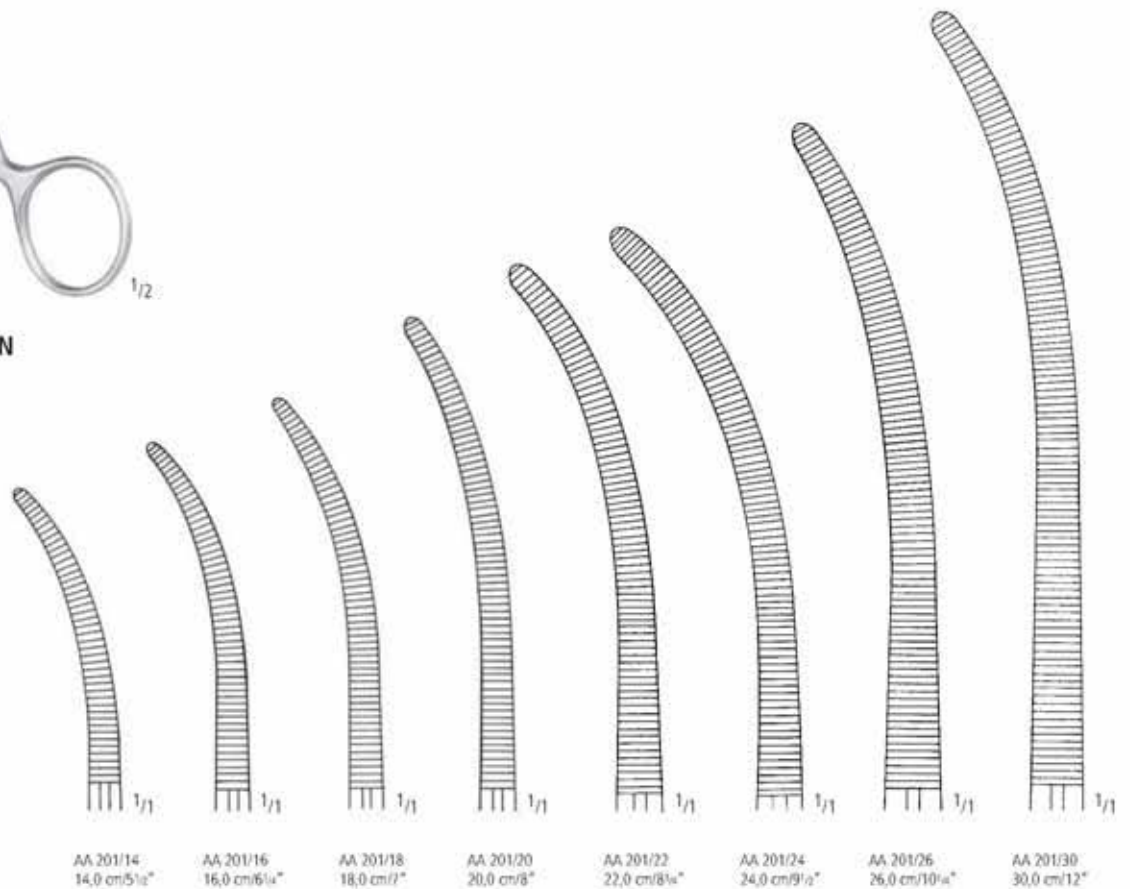
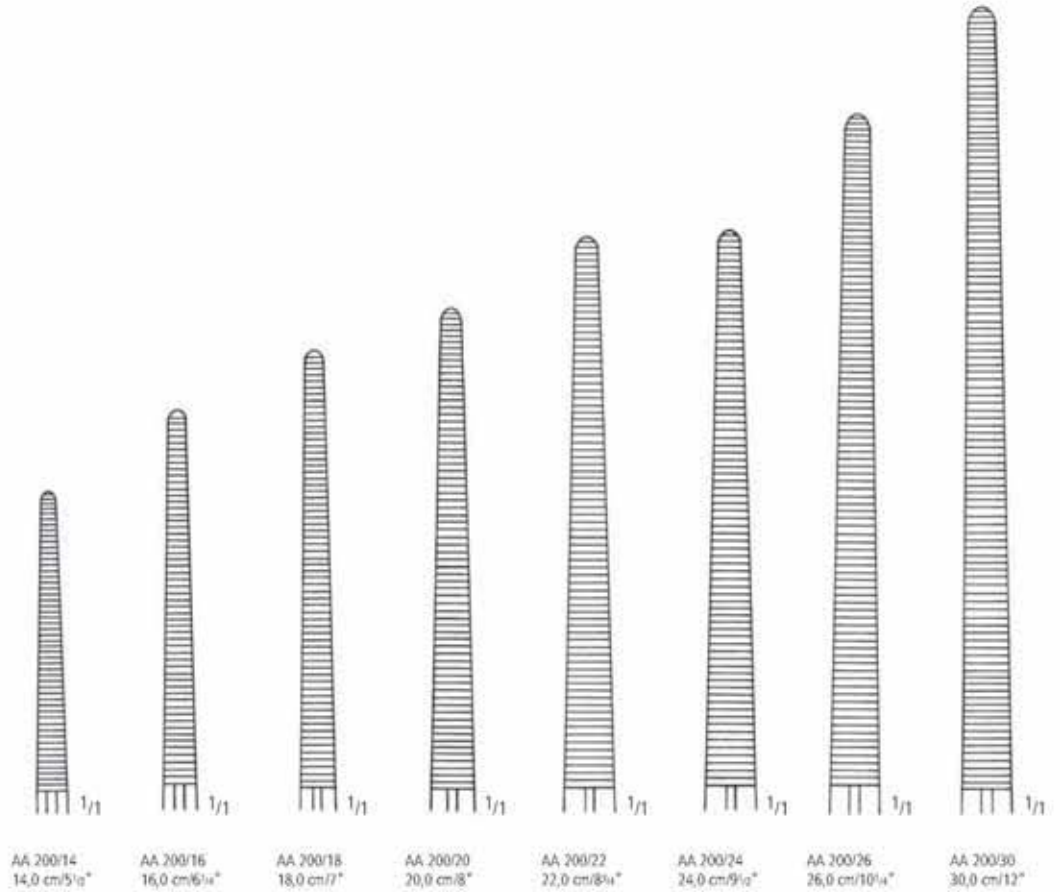

Arterienklemmen  
 Artery Forceps  
 Pinzas hemostáticas  
 Pincès hémostatiques  
 Pinze emostatiche

AA

AB

AC

AD

AE

AF

AK

AL

AO

KA

KK

X



OCHSNER-KOCHER 1:2

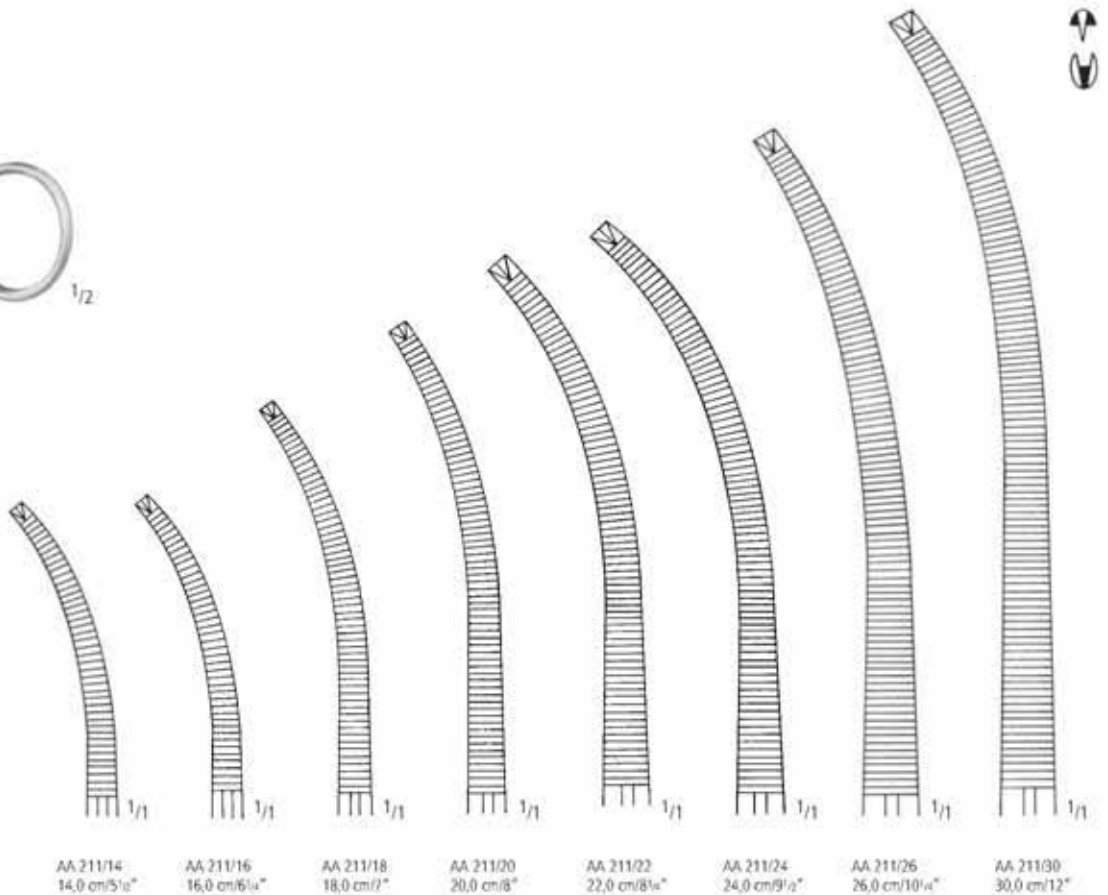
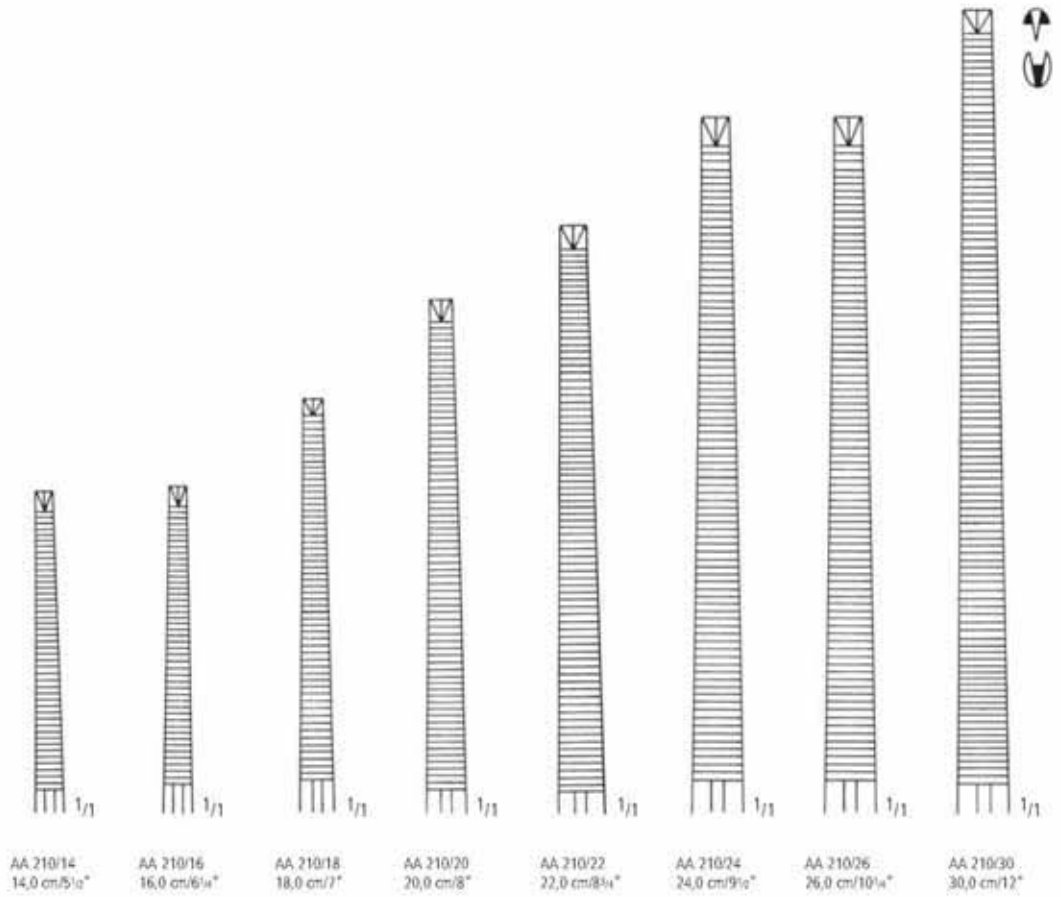



Grazile Arterienklemmen  
 Delicate Artery Forceps  
 Pinzas hemostáticas delgadas  
 Pincas hémostatiques grâcles  
 Pinze emostatiche delicate

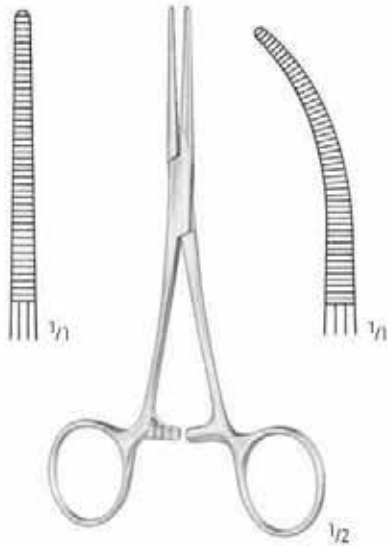

**PEAN - DELICATE**

AA 214/13	AA 215/13
AA 214/14	AA 215/14
AA 214/16	AA 215/16

**JULES PEAN**, born 1830, died 1898, was the most important French gynecological surgeon of his time. He studied at Paris 1860. 1864 Pean was the first surgeon in Paris to perform an ovariectomy. By the use of Pean pins he introduced forceps pressure for control of hemorrhage, thus he invented the most used surgical instrument, next to the scalpel.

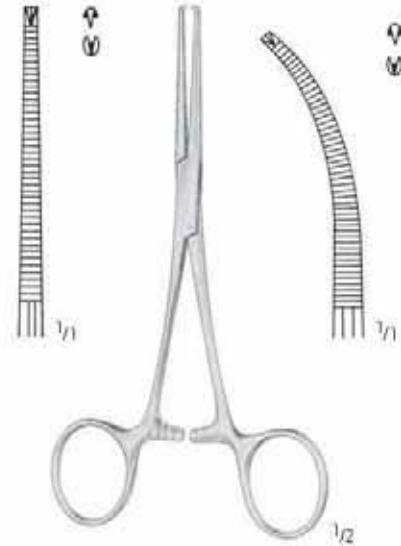

**KOCHER 1:2 - DELICATE**

AA 216/13	AA 217/13
AA 216/14	AA 217/14
AA 216/16	AA 217/16

**ALBERT J. OCHSNER**, born 1858, died 1925. He devoted much time to attending and participating in medical discussions and was member of all leading societies in his fields.

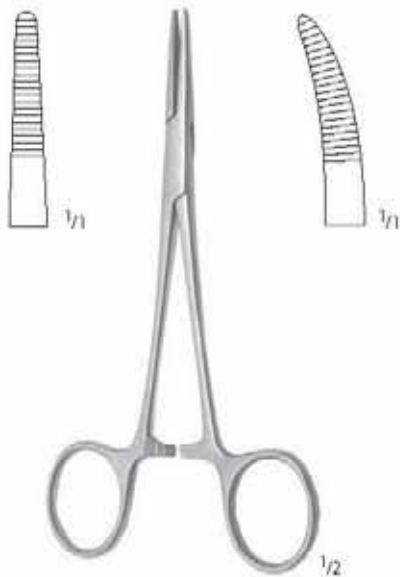

**CAIRNS**

AA 218/15	15,0 cm/6"	AA 219/15
-----------	------------	-----------



**DUNHILL**

AA 220/13	13,0 cm/5"
-----------	------------



KLEMMEN HEMOSTATS PINZAS HEMOSTATICAS PINCES HEMOSTATIQUES PINZE EMOSTATICHE

Arterienklemmen, Präparier- und Ligaturklemmen  
 Artery Forceps, Dissecting and Ligature Forceps  
 Pinzas hemostáticas, Pinzas para preparaciones y ligaduras  
 Pincès hémostatiques, Pincès à disséquer et à ligatures  
 Pinze emostatiche, Pinze per preparazioni e legature

AA  
 AB  
 AC  
 AD  
 AE  
 AF  
 AK  
 AL  
 AO  
 KA  
 KK  
 X



**OVERHOLT-GEISSENDOERFER**

21,0 cm/8<sup>1</sup>/<sub>4</sub>"  
 27,0 cm/10<sup>3</sup>/<sub>4</sub>"

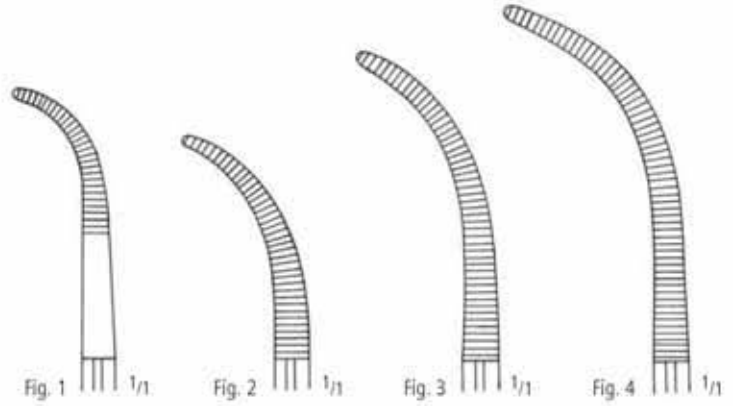

Fig. 1 1/1 AA 221/01  
 Fig. 2 1/1 AA 221/02  
 Fig. 3 1/1 AA 221/03  
 Fig. 4 1/1 AA 221/04  
 AA 223/01  
 AA 223/02  
 AA 223/03  
 AA 223/04

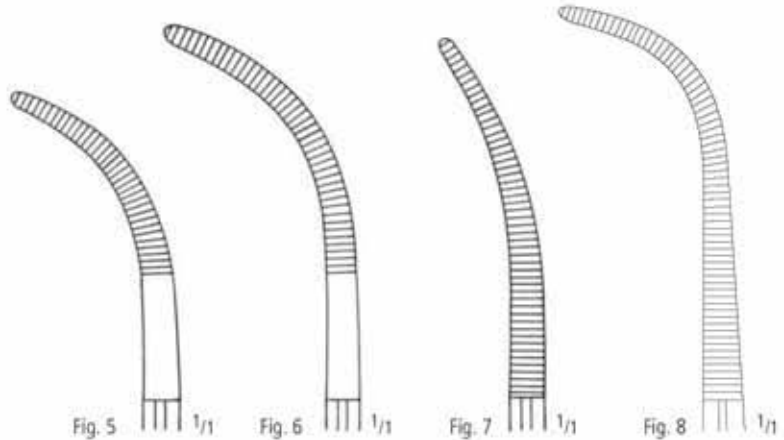

Fig. 5 1/1 AA 221/05  
 Fig. 6 1/1 AA 221/06  
 Fig. 7 1/1 AA 221/07  
 Fig. 8 1/1 AA 224/08  
 AA 223/05  
 AA 223/06  
 AA 223/07



**BABY-OVERHOLT**

AA 225/13  
 13,5 cm/5<sup>1</sup>/<sub>4</sub>"

Präparier- und Ligaturklemmen  
 Dissecting and Ligature Forceps  
 Pinzas para preparaciones y ligaduras  
 Pincas à disséquer et à ligatures  
 Pinze per preparazioni e legature



**OVERHOLT**  
 AA 229/01  
 18,5 cm/7<sup>1</sup>/<sub>3</sub>"



**OVERHOLT**  
 AA 229/02  
 20,5 cm/8"



**OVERHOLT**  
 AA 229/03  
 21,0 cm/8<sup>1</sup>/<sub>4</sub>"



**OVERHOLT**  
 AA 229/04  
 21,5 cm/8<sup>1</sup>/<sub>2</sub>"

S-förmig gebogen  
 S-shaped  
 curvas en S  
 courbes en S  
 curve in S

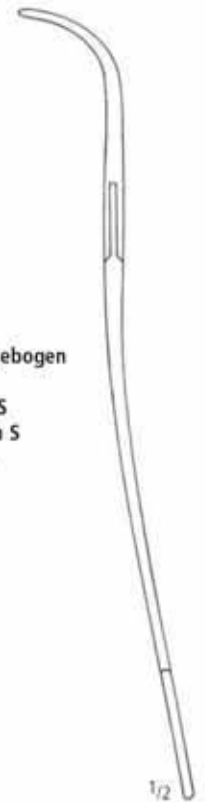

KLEMMEN HEMOSTATS PINZAS HEMOSTATICAS PINCES HEMOSTATIQUES PINZE EMOSTATICHE

Arterienklemmen, Präparier- und Ligaturklemmen  
 Artery Forceps, Dissecting and Ligature Forceps  
 Pinzas hemostáticas, Pinzas para preparaciones y ligaduras  
 Pincés hémostatiques, Pincés à disséquer et à ligatures  
 Pinze emostatiche, Pinze per preparazioni e legature

AA  
 AB  
 AC  
 AD  
 AE  
 AF  
 AG  
 AH  
 AI  
 AJ  
 AK  
 AL  
 AO  
 AP  
 AQ  
 AR  
 AS  
 AT  
 AU  
 AV  
 AW  
 AX  
 AY  
 AZ



**BABY-ADSON**  
 AA 235/14  
 14,0 cm/5 1/2"



**BABY-ADSON**  
 AA 237/18  
 18,0 cm/7"

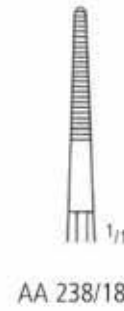

AA 238/18



**ADSON**  
 18,5 cm/7 1/3"

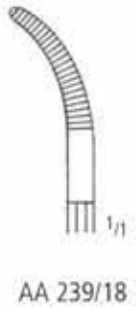

AA 239/18



AA 240/18

AA 241/18

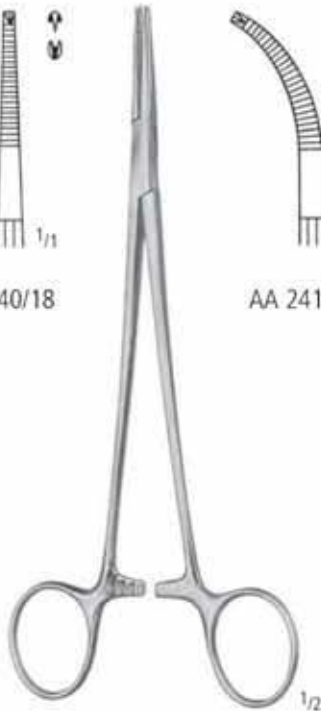

**ADSON 1:2**  
 18,5 cm/7 1/3"



**MEEKER**

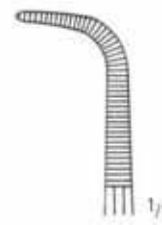

AA 251/18  
 18,0 cm/7"

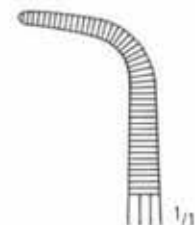

AA 251/28  
 28,0 cm/11"

Arterienklemmen  
 Artery Forceps  
 Pinzas hemostáticas  
 Pincas hémostatiques  
 Pinze emostatiche



**DIXON-LOVELACE**  
 AA 286/15  
 15,5 cm/6"



**DIXON-LOVELACE 1:2**  
 AA 288/15  
 15,5 cm/6"

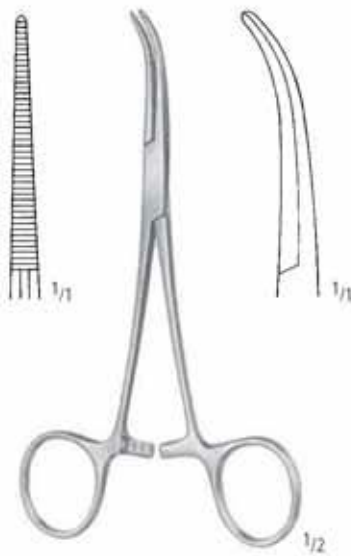

**DANDY**  
 AA 291/14  
 14,0 cm/5 1/2"

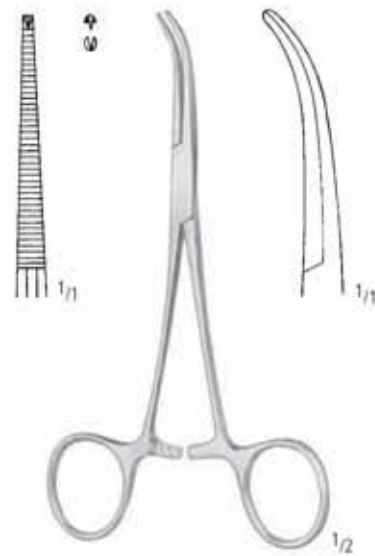

**DANDY 1:2**  
 AA 293/14  
 14,0 cm/5 1/2"

Arterienklemmen, Tonsillenklemmen  
 Artery forceps, Tonsil Hemostatic forceps  
 Pinzas hemostáticas, pinzas hemostáticas para amígdalas  
 Pincés hémostatiques, pincés hémostatiques pour amygdales  
 Pinze emostatiche, pinze emostatiche per tonsille

AA  
 AB  
 AC  
 AD  
 AE  
 AF  
 AG  
 AH  
 AI  
 AJ  
 AK  
 AL  
 AM  
 AN  
 AO  
 AP  
 AQ  
 AR  
 AS  
 AT  
 AU  
 AV  
 AW  
 AX  
 AY  
 AZ

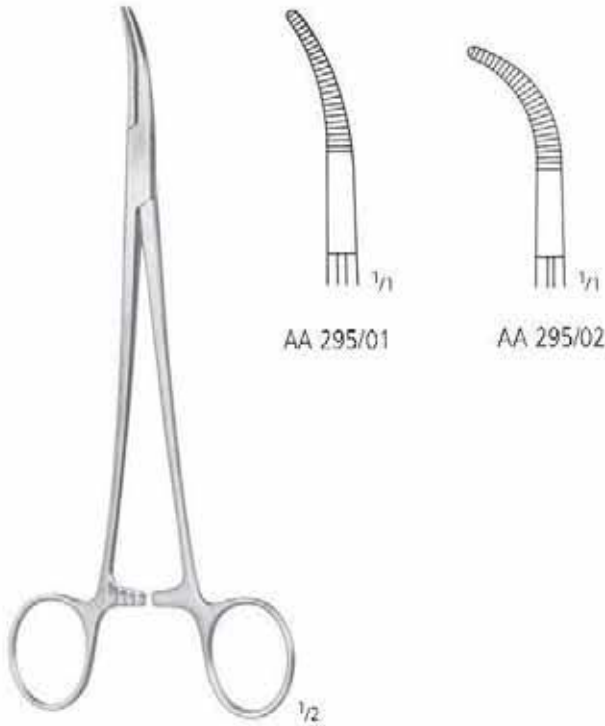

AA 295/01

AA 295/02

**SCHNIDT-SAWTELL**  
 19,0 cm/7 1/2"

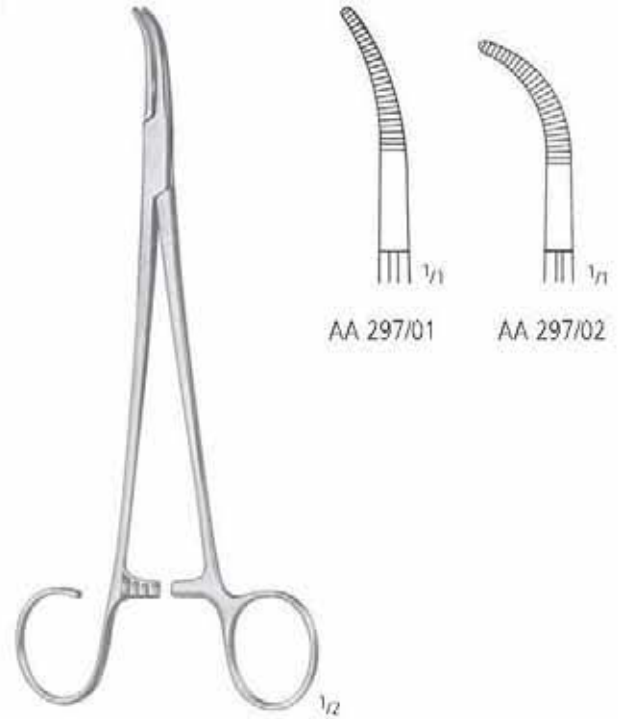

AA 297/01

AA 297/02

**SCHNIDT-SAWTELL**  
 19,0 cm/7 1/2"

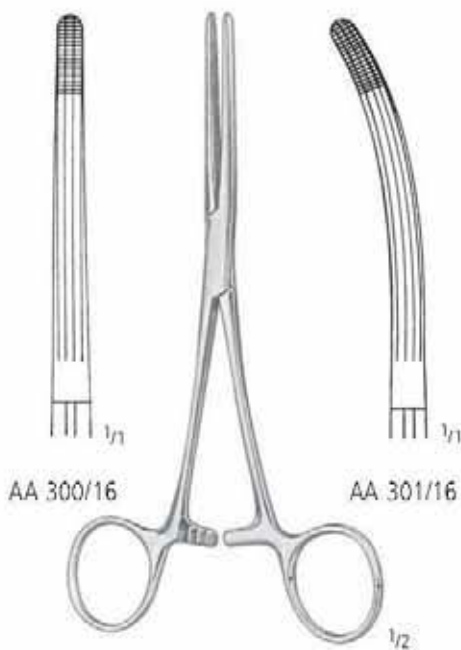

AA 300/16

AA 301/16

**ROCHESTER-CARMALT**

AA 300/16  
 AA 300/20

16,0 cm/6 1/4"  
 20,0 cm/8"

AA 301/16  
 AA 301/20

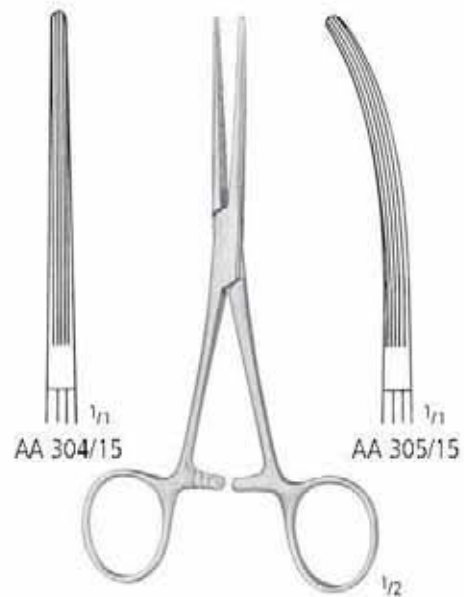

AA 304/15

AA 305/15

**BAINBRIDGE**

AA 304/15  
 AA 304/18

15,0 cm/6"  
 18,5 cm/7 1/3"

AA 305/15  
 AA 305/18



Arterienklemmen  
 Artery Forceps  
 Pinzas hemostáticas  
 Pincas hémostatiques  
 Pinze emostatiche

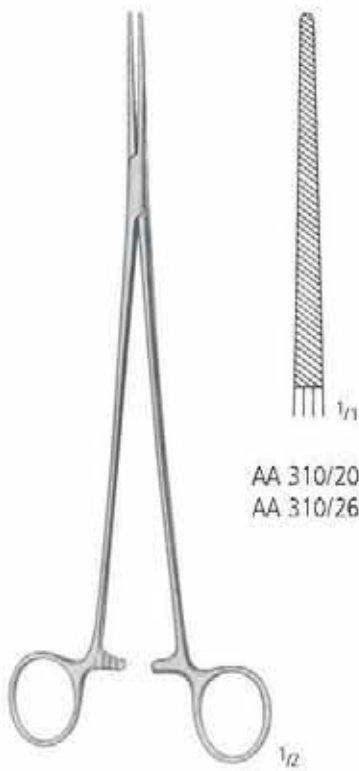

**BENGOLEA**

AA 310/20  
 AA 310/26

20,0 cm/8"  
 26,0 cm/10 1/2"



AA 311/20  
 AA 311/26

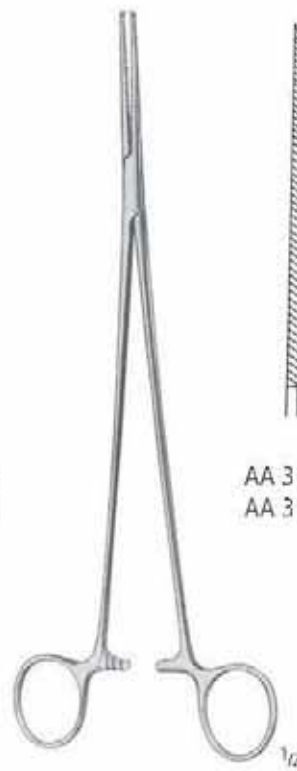

**BENGOLEA 1:2**

AA 312/20  
 AA 312/26

20,0 cm/8"  
 26,0 cm/10 1/2"

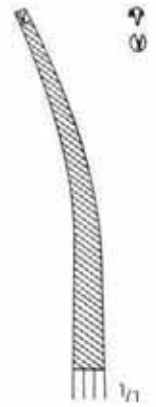

AA 313/20  
 AA 313/26

Aurikelklemmen, Präparier- und Ligaturklemmen  
 Auricle Forceps, Dissecting and Ligature Forceps  
 Pinzas para auricula, Pinzas para preparaciones y ligaduras  
 Pincès auriculaires, Pincès à disséquer et à ligatures  
 Pinze auricolari, Pinze per preparazioni e legature

AA  
 AB  
 AC  
 AD  
 AE  
 AF  
 AG  
 AH  
 AI  
 AJ  
 AK  
 AL  
 AM  
 AN  
 AO  
 AP  
 AQ  
 AR  
 AS  
 AT  
 AU  
 AV  
 AW  
 AX  
 AY  
 AZ

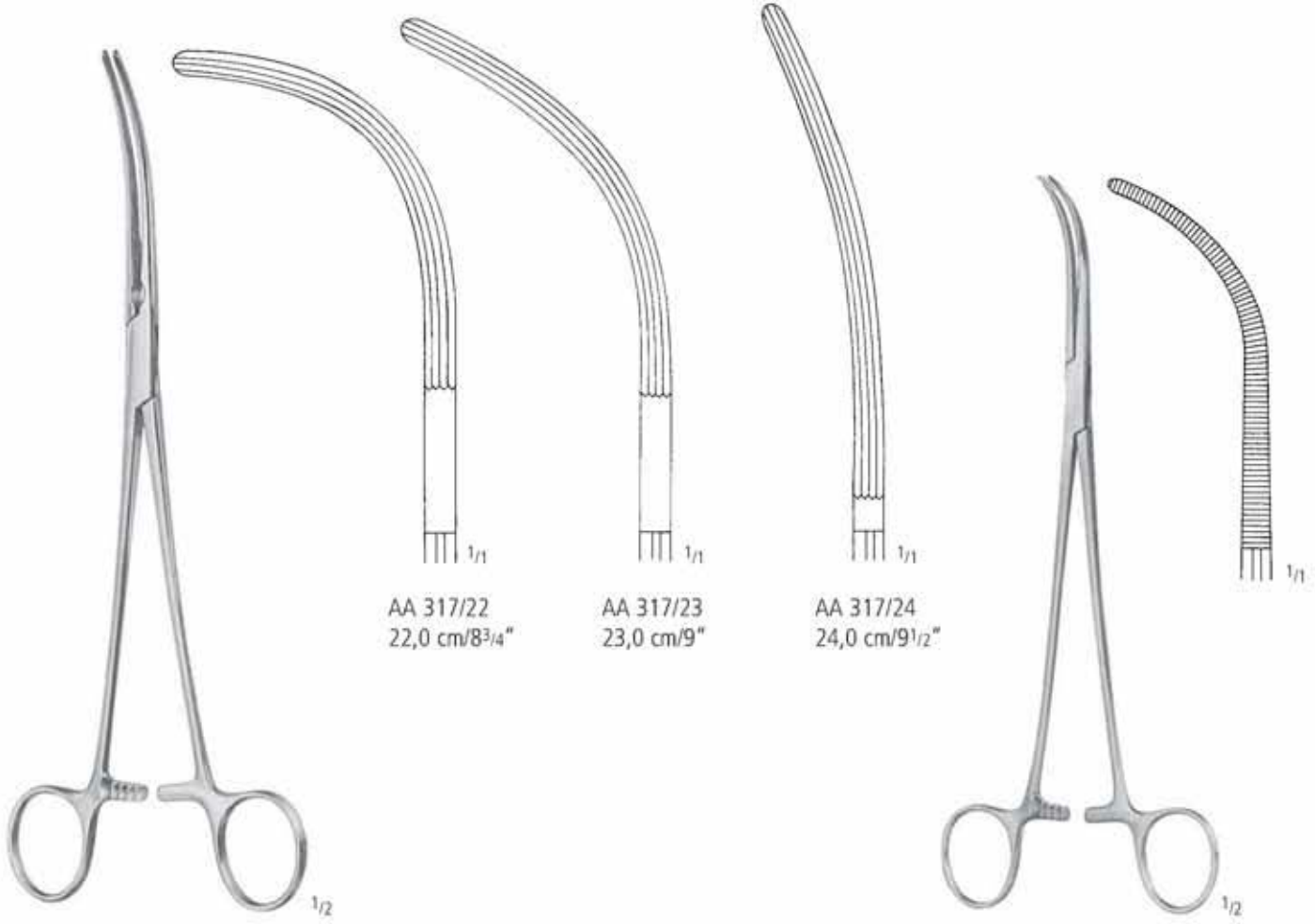

**CRAFOORD-SELLORS**

**OVERHOLT-MIXTER**

AA 319/21  
 21,0 cm/8<sup>1</sup>/<sub>4</sub>"

Arterienklemmen, Bronchusklemmen  
 Artery Forceps, Bronchus Forceps  
 Pinzas hemostáticas, Pinzas-clamps bronquias  
 Pincés hémostatiques, Pincés-clamps à bronches  
 Pinze emostatiche, Pinze per bronchi

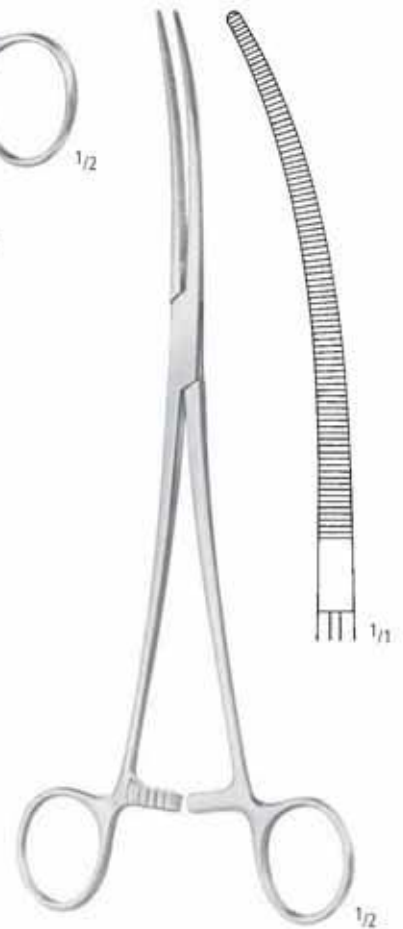
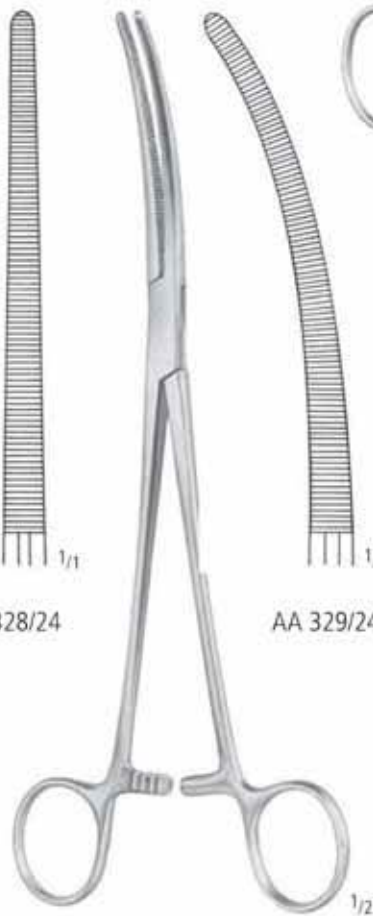
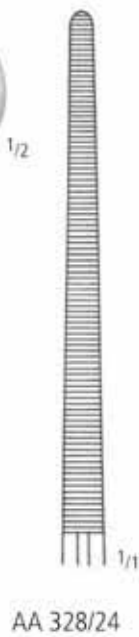
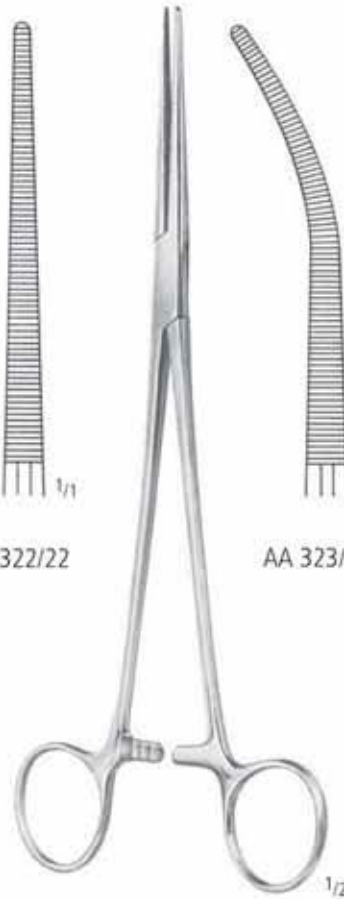
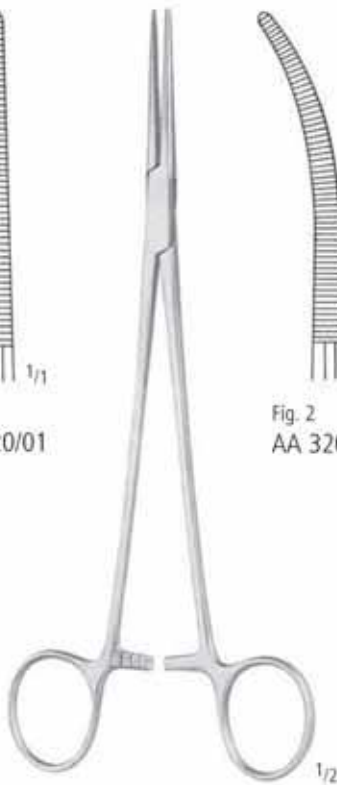
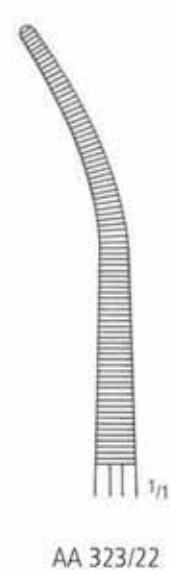
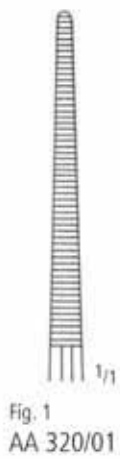

Präparier- und Ligaturklemmen  
 Dissecting and Ligature Forceps  
 Pinzas para preparaciones y ligaduras  
 Pincès à disséquer et à ligatures  
 Pinze per preparazioni e legature

AA  
 AB  
 AC  
 AD  
 AE  
 AF  
 AK  
 AL  
 AO  
 KA  
 KK  
 X



**RUMEL**  
 23,0 cm/9"

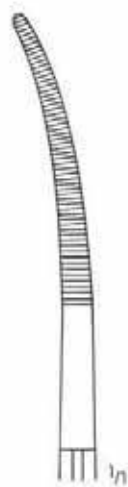

AA 335/01

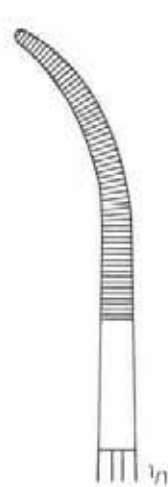

AA 335/02

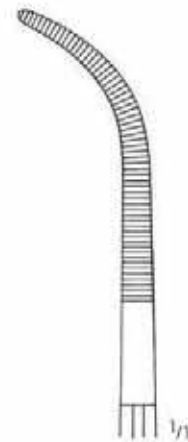

AA 335/03

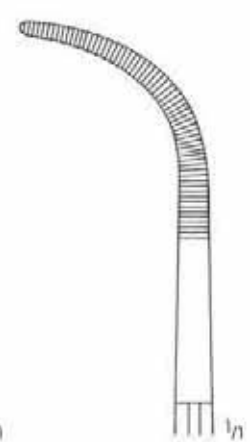

AA 335/04

Präparier- und Ligaturklemmen  
 Dissecting and Ligature Forceps  
 Pinzas para preparaciones y ligaduras  
 Pincès à disséquer et à ligatures  
 Pinze per preparazioni e legature

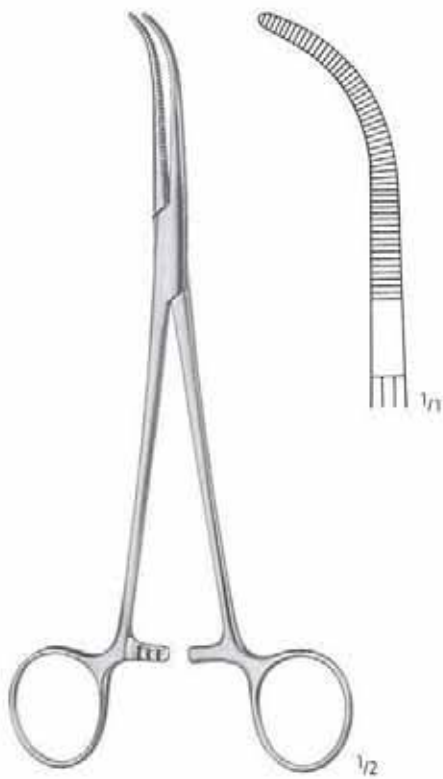

**JOHNS HOPKINS**  
 AA 338/20  
 20,0 cm/8"

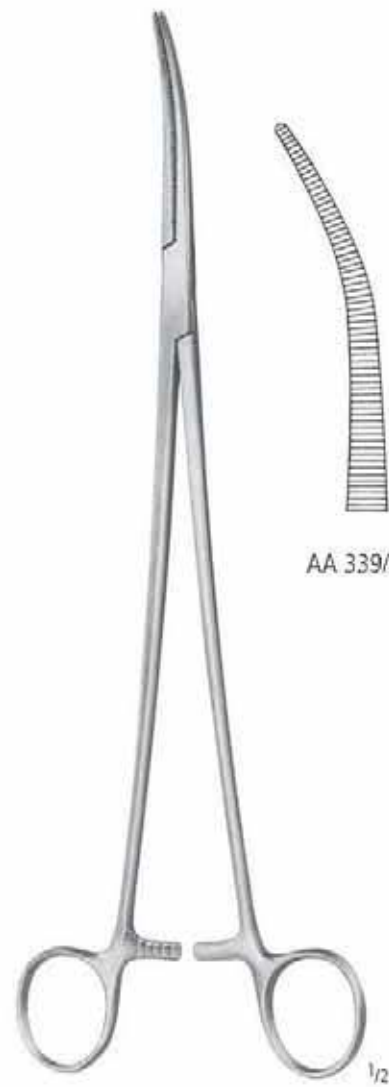

**ZENKER**  
 29,5 cm/11 1/2"

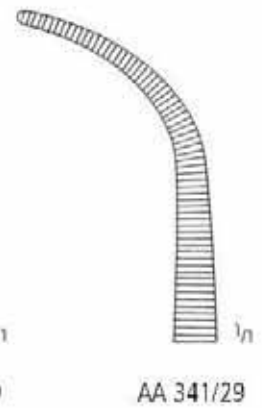
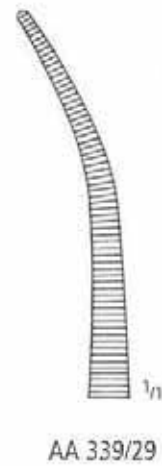



Präparier- und Ligaturklemmen  
 Dissecting and Ligature Forceps  
 Pinzas para preparaciones y ligaduras  
 Pincès à disséquer et à ligatures  
 Pinze per preparazioni e legature

AA  
 AB  
 AC  
 AD  
 AE  
 AF  
 AG  
 AH  
 AI  
 AJ  
 AK  
 AL  
 AM  
 AN  
 AO  
 AP  
 AQ  
 AR  
 AS  
 AT  
 AU  
 AV  
 AW  
 AX  
 AY  
 AZ



**MIXTER**  
 15,5 cm/6"  
 19,0 cm/7½"

AA 345/15  
 AA 345/19

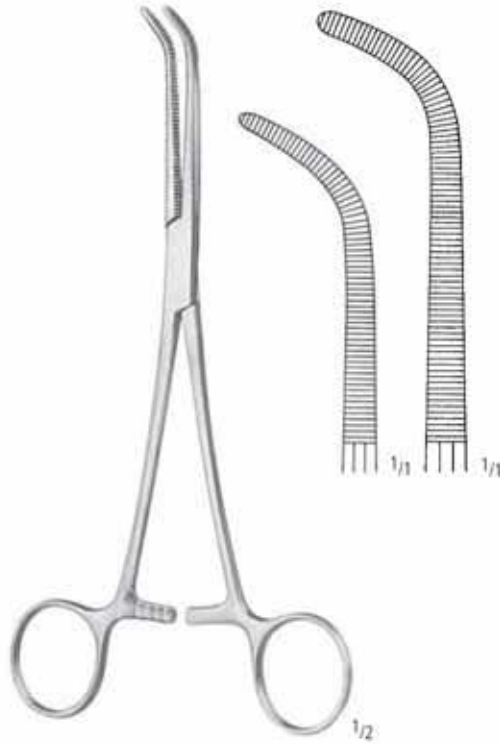

**MIXTER-O'SHAUGNESSY**  
 15,5 cm/6"  
 19,0 cm/7½"

AA 347/15  
 AA 347/19



**BABY-MIXTER**  
 AA 348/18  
 18,0 cm/7"



AA 349/01 AA 349/02

**BABY-MIXTER**  
 14,0 cm/5½"



**MIXTER**



Fig. 1  
 AA 353/22  
 22,0 cm/8¾"



Fig. 2  
 AA 353/25  
 25,0 cm/10"

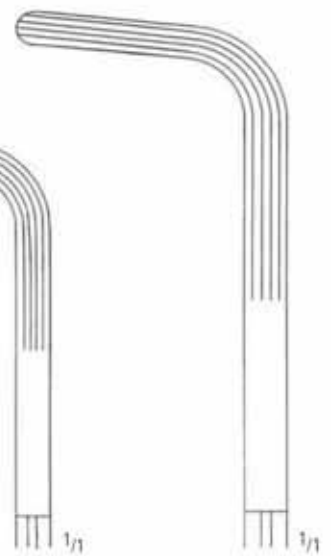
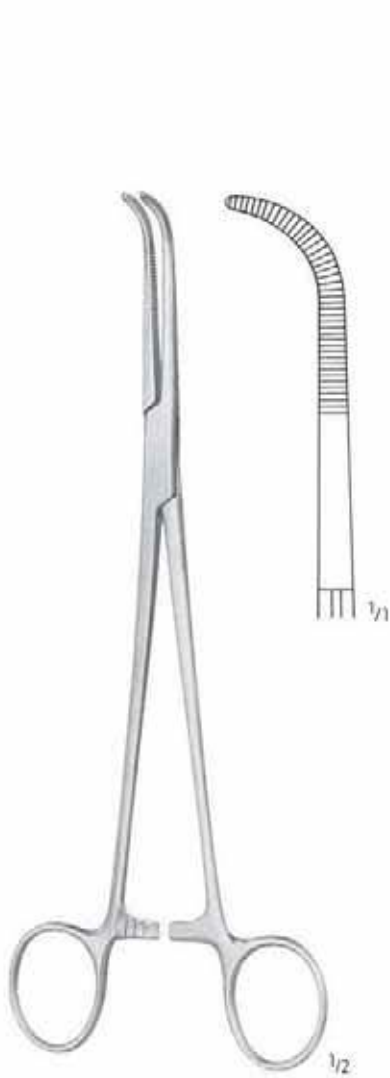
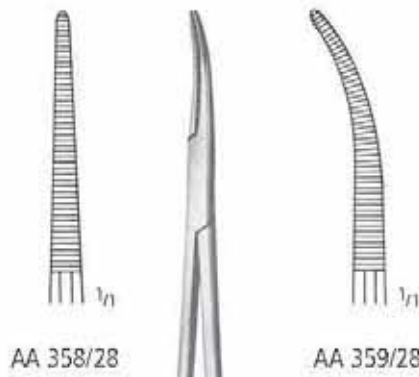

Fig. 3  
 AA 353/28  
 28,0 cm/11"

Präparier- und Ligaturklemmen  
 Dissecting and Ligature Forceps  
 Pinzas para preparaciones y ligaduras  
 Pincès à disséquer et à ligatures  
 Pinze per preparazioni e legature



**MIXTER**  
 AA 355/23  
 23,0 cm/9"



AA 358/28

AA 359/28



**BRIDGE**  
 28,0 cm/11"



**LAWRENCE**  
 AA 361/28  
 28,0 cm/11"

Präparier- und Ligaturklemmen  
 Dissecting and Ligature Forceps  
 Pinzas para preparaciones y ligaduras  
 Pincès à disséquer et à ligatures  
 Pinze per preparazioni e legature

AA  
 AB  
 AC  
 AD  
 AE  
 AF  
 AK  
 AL  
 AO  
 KA  
 KK  
 X



**KANTROWITZ**

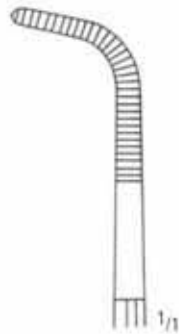

AA 363/20  
20,0 cm/8"

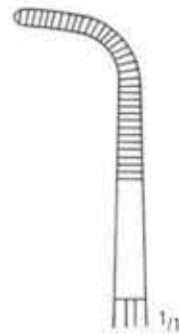

AA 363/24  
24,0 cm/9 1/2"

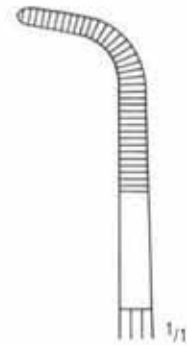

AA 363/28  
28,0 cm/11"



**GEMINI**

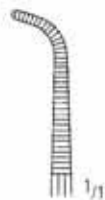

AA 365/14  
14,0 cm/5 1/2"



AA 365/18  
18,0 cm/7"



AA 365/22  
22,0 cm/8 3/4"

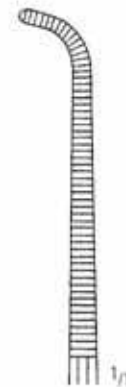

AA 365/25  
25,0 cm/10"



AA 365/28  
28,0 cm/11"

Präparier- und Ligaturklemmen  
 Dissecting and Ligature Forceps  
 Pinzas para preparaciones y ligaduras  
 Pincès à disséquer et à ligatures  
 Pinze per preparazioni e legature

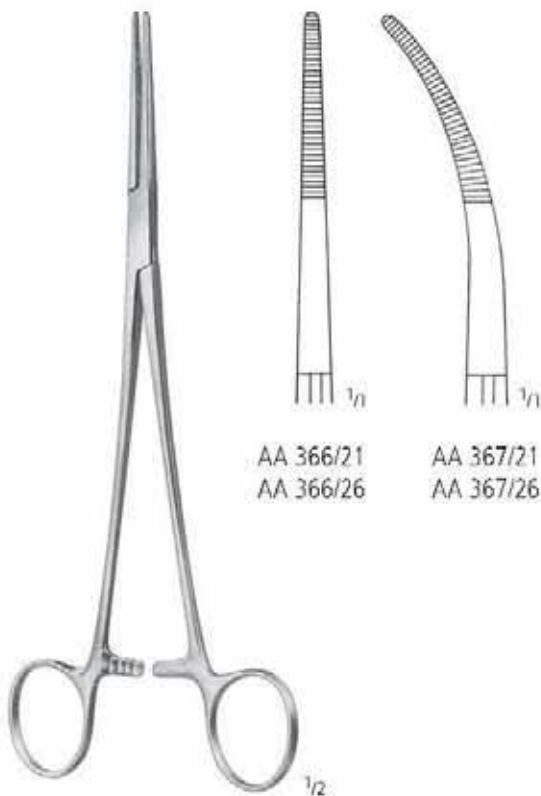

**TOENNIS**  
 21,0 cm/8<sup>1</sup>/<sub>4</sub>"  
 26,0 cm/10<sup>1</sup>/<sub>2</sub>"

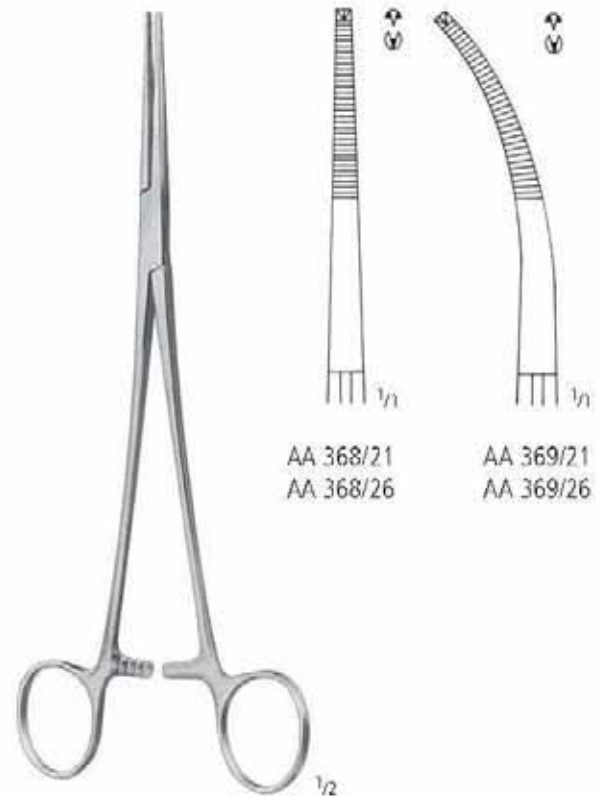

**TOENNIS 1:2**  
 21,0 cm/8<sup>1</sup>/<sub>4</sub>"  
 26,0 cm/10<sup>1</sup>/<sub>2</sub>"

Präparier- und Ligaturklemmen  
 Dissecting and Ligature Forceps  
 Pinzas para preparaciones y ligaduras  
 Pincès à disséquer et à ligatures  
 Pinze per preparazioni e legature

AA  
 AB  
 AC  
 AD  
 AE  
 AF  
 AK  
 AL  
 AO  
 KA  
 KK  
 X

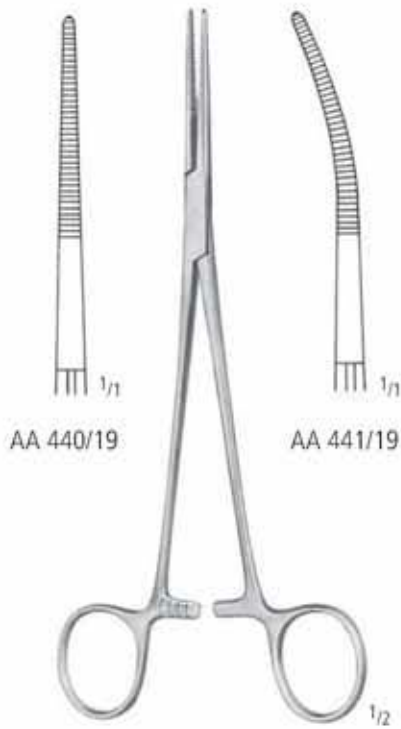

**BIRKETT**  
 19,0 cm/7<sup>1</sup>/<sub>2</sub>"



**WIKSTROEM**  
 AA 443/19  
 19,0 cm/7<sup>1</sup>/<sub>2</sub>"



Tuchklemmen  
Towel Forceps  
Pinzas para compresas, Pinzas de campo  
Pincas à champs, Pincas à compresas  
Pinze per fissare le compresse (fissatele)



**SCHAEDEL**  
AA 710/09  
9,0 cm/3 1/2"



**JONES**  
5,0 cm/2" AA 711/05  
9,0 cm/3 1/2" AA 711/09



**ENGL. MODELL**  
AA 717/09  
9,0 cm/3 1/2"



**DOYEN**  
AA 721/18  
18,0 cm/7"



**BERNHARD**  
AA 726/16  
16,5 cm/6 1/2"



**LANE**  
15,0 cm/6" AA 730/15  
18,0 cm/7" AA 730/18  
20,0 cm/8" AA 730/20

Tuchklemmen  
Towel Forceps  
Pinzas para compresas, Pinzas de campo  
Pinces à champs, Pinces à compresses  
Pinze per fissare le compresse (Fissatele)



AA 749/11  
11,0 cm/4<sup>1</sup>/<sub>3</sub>"

- mit Schlauch- oder Kabelhalter
- with clip for tubing or cable
- con porta-tubo o porta-cable
- avec clamp porte-tube ou porte-corton d'alimentation
- con porta tubo o porta cavo



**BACKHAUS**

8,0 cm/3" AA 751/08  
11,0 cm/4<sup>1</sup>/<sub>3</sub>" AA 751/11  
13,0 cm/5" AA 751/13  
15,0 cm/6" AA 751/15



**BALL & SOCKET**

11,0 cm/4<sup>1</sup>/<sub>3</sub>" AA 753/11  
13,0 cm/5" AA 753/13

für Papiertücher  
for paper tissues  
para servilletas de papel  
pour serviettes en papier  
per tessuti di carta



**ROEDER**

13,0 cm/5" AA 761/13  
15,0 cm/6" AA 761/15



**LORNA**

10,0 cm/4" AA 763/10  
13,0 cm/5" AA 763/13



**TOHOKU-JAPAN**

10,0 cm/4" AA 764/10  
13,0 cm/5" AA 764/13



**PEERS**

AA 765/14  
14,5 cm/5<sup>3</sup>/<sub>4</sub>"

AA  
AB  
AC  
AD  
AE  
AF  
AK  
AL  
AO  
KA  
KK  
X

Schlauchklemmen  
Tubing Clamps  
Pinzas para tubos  
Presses-tube  
Pinze serratubi



**PRESBYTERIAN**

16,5 cm/6<sup>1</sup>/<sub>2</sub>" AA 790/16  
18,0 cm/7" AA 790/18



**KLINIKUM BERLIN**

AA 792/14  
14,5 cm/5<sup>3</sup>/<sub>4</sub>"  
mit langer Sperre  
with long ratchet  
con cremallera larga  
à crémaillère extra longue  
con cremagliera extra lunga



AA 794/15 AA 794/18 AA 794/20

AA 794/15 15,5 cm/6"  
AA 794/18 18,0 cm/7"  
AA 794/20 20,0 cm/8"



AA 796/15 AA 796/18 AA 796/20

AA 796/15  
AA 796/18  
AA 796/20

---

**tini**<sup>®</sup> instruments

**nopa**<sup>®</sup> instruments

**ti**tan-**ni**trid Beschichtung  
**ti**tan-**ni**tride surface coating



tini

AB

>> Pinzetten • Forceps • Pinzas • Pincas • Pinze



AC

>> Scheren • Scissors • Tijeras • Ciseaux • Forbici



AE

>> Naht • Suture • Sutura • Suture • Sutura



KA

>> Orthopädie • Orthopaedics • Ortopedia • Orthopédie • Ortopedia

KK

>> Herz/Thorax • Cardiovascular • Cardiovascular • Cardiovasculaire • Cardiovascolare

KS

>> Neurochirurgie • Neurosurgery • Neurocirugia • Neurochirurgie • Neurochirurgia

- >> extrem lange Lebensdauer und Einsatzfähigkeit
- >> enorm hohe Verschleißfestigkeit - nur selten Nachschleifen notwendig
- >> blendfreie Oberfläche - keine störenden Lichtreflexionen
- >> mikroglatte Oberfläche - deutlich verbesserte Korrosionsbeständigkeit
- >> titan-nitrid ist gewebeverträglich und biokompatibel
- >> anti-allergene Schutzfunktion
  
- >> longer durability and usability
- >> enormous high abrasion resistance - sharpening is hardly ever necessary
- >> reduction of reflective glare - no incommoding luminous reflectance
- >> micro-smooth surface - obviously improved corrosion resistance
- >> titan-nitride is tissuecompatible and biocompatible
- >> anallergenic protection





PINZETTEN  
FORCEPS  
PINZAS  
PINCES  
PINZE

AB

nopa<sup>®</sup> instruments

Weitere Pinzetten finden Sie in unserem Katalog  
"Allgemeine Chirurgie" in Gruppe AB.

For further forceps kindly refer to our catalogue  
"General Surgery", section AB.

Para pinzas adicionales, por favor consulte nuestro  
catálogo de "Cirugía general", grupo AB.

Pour des pinces supplémentaires, consultez notre  
catalogue "Chirurgie Generale", section AB.

Per gli altri pinze, consultare il nostro catalogo  
"Chirurgia Generale", gruppo AB.







titan instruments

nopa<sup>®</sup> instruments

**Besonderheit:**

nopa Titan Instrumente bieten insbesondere in der Herz-Thorax-Chirurgie Vorteile gegenüber herkömmlichen Instrumenten. Titan ist ca. 45% leichter als rostfreier Edelstahl, weshalb Titan Instrumente weniger traumatisierend sind. Titan ist außerdem ein vollkommen korrosionsbeständiges und antimagnetisches Material. nopa Titan Instrumente bedeuten größtmöglichen Komfort für den Chirurgen.

**Features:**

nopa Titan Instruments provide especially in Cardiovascular surgery a significant advantage compared to other Instruments. Titan is approximately 45% lighter than stainless steel. For that reason, Titan Instruments are less traumatic. Besides that, Titan is a completely stainless and anti-magnetic material. nopa Titan Instruments are the most comfortable choice for the Cardiovascular surgeon.

AB 100/12 T	ADSON DRESSING FORCEPS 12,0 CM
AB 110/12 T	ADSON TISSUE FCPS 1X2 TEETH 12,0 CM
AB 116/07 T	ADSON-BROWN TISS. FCPS STR 7X7 TEETH 12,0 CM
AB 120/15 T	SEMKEN DRESSING FORCEPS STR 15,5 CM
AB 160/18 T	GERALD DRESSING FORCEPS STR 18,0 CM
AB 170/18 T	GERALD TISSUE FORCEPS STR 1X2 TEETH 17,0 CM
AB 542/15 T	SUTURE TYING FORCEPS 0,3 MM STR 15,0 CM
AB 860/16 T	DE BAKEY ATRAUMA FCPS STR 1,5 MM 16,0 CM
AB 860/20 T	DE BAKEY ATRAUMA FCPS STR 1,5 MM 20,0 CM
AB 860/24 T	DE BAKEY ATRAUMA FCPS STR 1,5 MM 24,0 CM
AB 862/16 T	DE BAKEY ATRAUMA FCPS STR 2,0 MM 16,0 CM
AB 862/20 T	DE BAKEY ATRAUMA FCPS STR 2,0 MM 20,0 CM
AB 862/24 T	DE BAKEY ATRAUMA FCPS STR 2,0 MM 24,0 CM
AB 864/16 T	DE BAKEY ATRAUMA FCPS STR 2,8 MM 16,0 CM
AB 864/20 T	DE BAKEY ATRAUMA FCPS STR 2,8 MM 20,0 CM



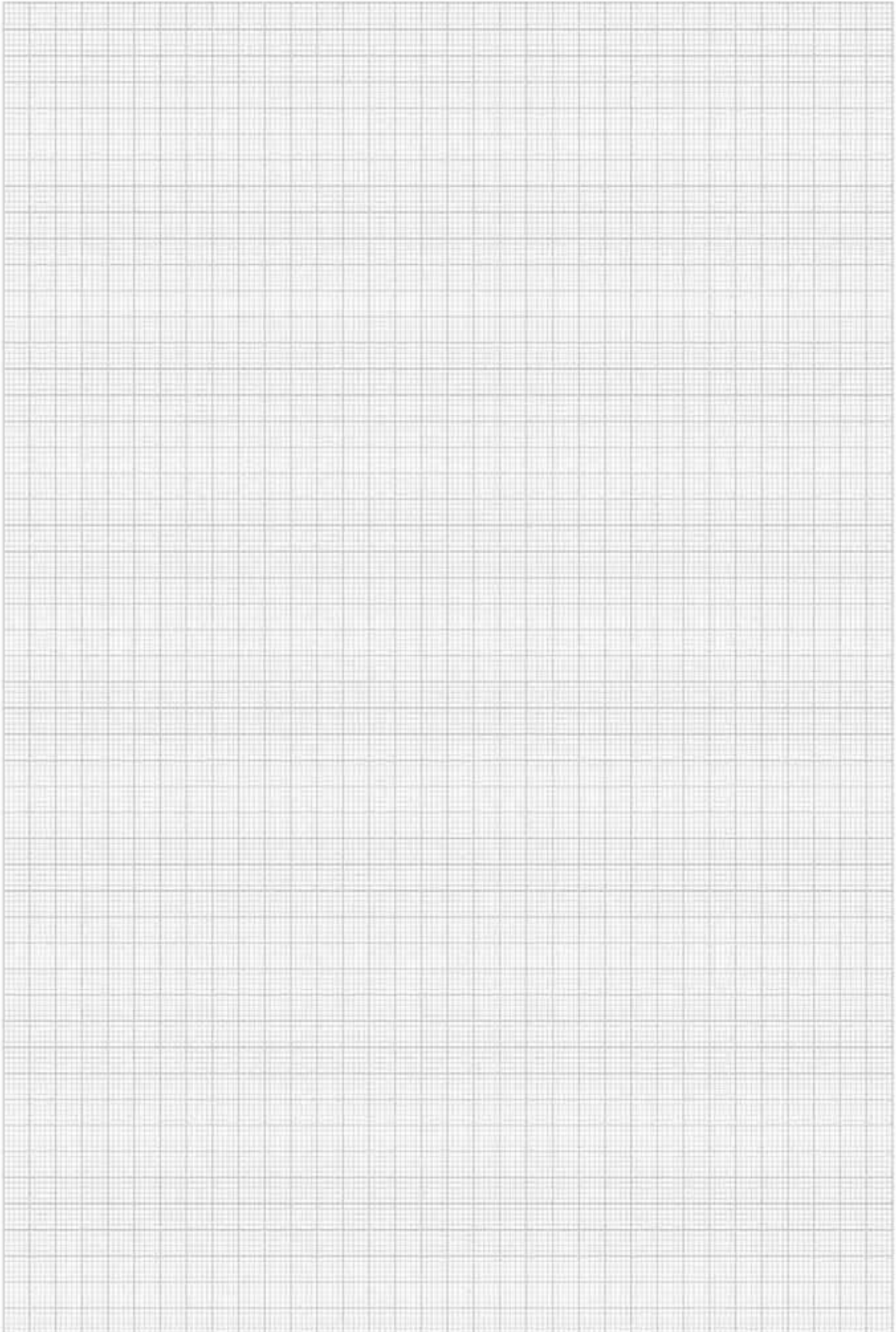



PINZETTEN FORCEPS PINZAS PINCES PINZE

Anatomische Pinzetten, Chirurgische Pinzetten  
 Dressing forceps, Tissue forceps  
 Pinzas de disección, Pinzas de disección con dientes  
 Pincers à dissection, Pincers à griffes  
 Pinze anatomiche per dissezione, Pinze chirurgiche a denti di topo



1/2

STANDARD

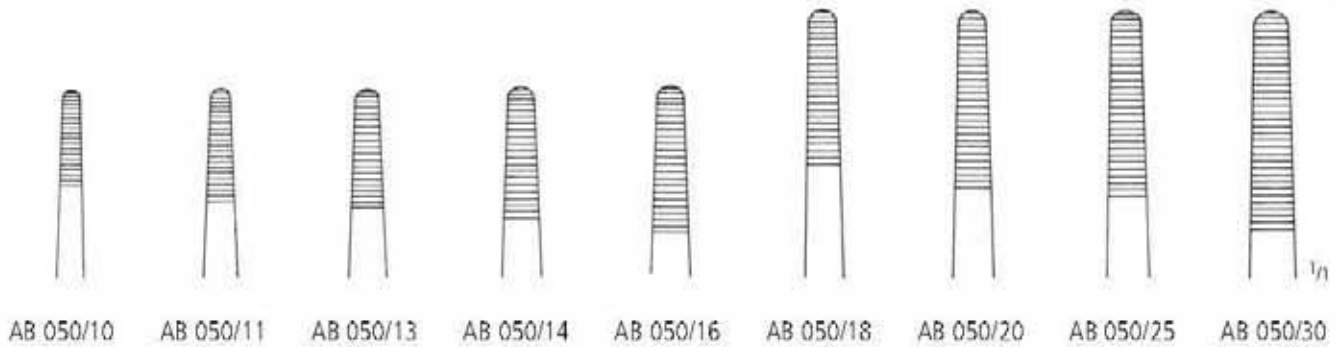

AB 050/10 AB 050/11 AB 050/13 AB 050/14 AB 050/16 AB 050/18 AB 050/20 AB 050/25 AB 050/30

10,5 cm/4 1/4"	AB 050/10
11,5 cm/4 1/2"	AB 050/11
13,0 cm/5"	AB 050/13
14,5 cm/5 3/4"	AB 050/14
16,0 cm/6 1/4"	AB 050/16
18,0 cm/7"	AB 050/18
20,0 cm/8"	AB 050/20
25,0 cm/10"	AB 050/25
30,0 cm/12"	AB 050/30



1/2

1:2  
STANDARD

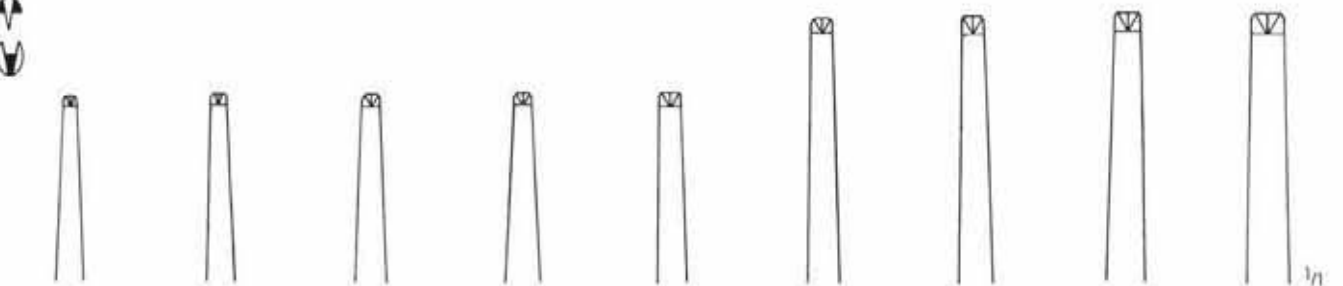

AB 060/10 AB 060/11 AB 060/13 AB 060/14 AB 060/16 AB 060/18 AB 060/20 AB 060/25 AB 060/30

10,5 cm/4 1/4"	AB 060/10
11,5 cm/4 1/2"	AB 060/11
13,0 cm/5"	AB 060/13
14,5 cm/5 3/4"	AB 060/14
16,0 cm/6 1/4"	AB 060/16
18,0 cm/7"	AB 060/18
20,0 cm/8"	AB 060/20
25,0 cm/10"	AB 060/25
30,0 cm/12"	AB 060/30

AA  
AB  
AC  
AD  
AE  
AF  
AK  
AL  
AO  
KA  
KK  
X



Anatomische Pinzetten, Chirurgische Pinzetten  
 Dressing Forceps, Tissue forceps  
 Pinzas de disección, Pinzas de disección con dientes  
 Pincers à dissection, Pincers à griffes  
 Pinze anatomiche per dissezione, Pinze chirurgiche a denti di topo



AB 100/12



AB 102/12



AB 110/12



AB 112/12

12,0 cm/4<sup>3</sup>/<sub>4</sub>"  
 15,0 cm/6"

**ADSON**  
 AB 100/12  
 AB 100/15

**MICRO-ADSON**  
 AB 102/12  
 AB 102/15

**ADSON 1:2**  
 AB 110/12  
 AB 110/15

**MICRO-ADSON 1:2**  
 AB 112/12  
 AB 112/15

PINZETTEN FORCEPS PINZAS PINCES PINZE

Anatomische Pinzetten, Chirurgische Pinzetten  
 Dressing Forceps, Tissue Forceps  
 Pinzas de disección, Pinzas de disección con dientes  
 Pincés à dissection, Pincés à griffes  
 Pinze anatomiche per dissezione, Pinze chirurgiche a denti di topo



**ADSON**  
 AB 114/12  
 12,0 cm/4<sup>3</sup>/<sub>4</sub>"



**ADSON 1:2**  
 AB 115/12  
 12,0 cm/4<sup>3</sup>/<sub>4</sub>"



**ADSON-BROWN**  
 12,0 cm/4<sup>3</sup>/<sub>4</sub>"



**ADSON-BROWN**  
 AB 117/09  
 12,0 cm/4<sup>3</sup>/<sub>4</sub>"



**EWALD**  
 AB 118/01  
 12,0 cm/4<sup>3</sup>/<sub>4</sub>"

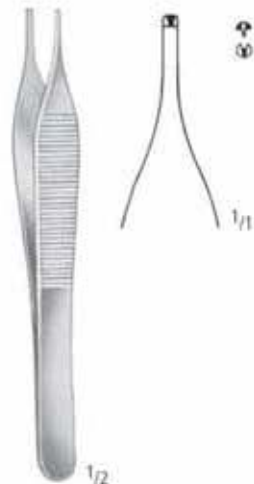

**EWALD 1:2**  
 AB 118/02  
 12,0 cm/4<sup>3</sup>/<sub>4</sub>"



**McINDOE**  
 AB 119/15  
 15,0 cm/6"

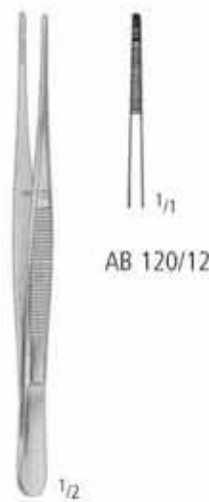

AB 120/12  
 AB 120/15

**SEMKEN**  
 12,5 cm/5"  
 15,5 cm/6"



AB 121/12  
 AB 121/15

AA  
 AB  
 AC  
 AD  
 AE  
 AF  
 AG  
 AH  
 AI  
 AJ  
 AK  
 AL  
 AM  
 AN  
 AO  
 AP  
 AQ  
 AR  
 AS  
 AT  
 AU  
 AV  
 AW  
 AX

**AB** PINZETTEN FORCEPS PINZAS PINCES PINZE

Anatomische Pinzetten, Chirurgische Pinzetten  
 Dressing Forceps, Tissue Forceps  
 Pinzas de disección, Pinzas de disección con dientes  
 Pincers à dissection, Pincers à griffes  
 Pinze anatomiche per dissezione, Pinze chirurgiche a denti di topo



AB 130/12



AB 131/12



**TAYLOR**  
 AB 140/17  
 17,5 cm/7"



**TAYLOR**  
 AB 141/17  
 17,5 cm/7"



**TAYLOR**  
 AB 142/17  
 17,5 cm/7"



**TAYLOR**  
 AB 143/17  
 17,5 cm/7"

**SEMKEN 1:2**  
 AB 130/12 12,5 cm/5"  
 AB 130/15 15,5 cm/6"  
 AB 131/12  
 AB 131/15

PINZETTES FORCEPS PINZAS PINCES PINZE

Anatomische Pinzetten, Chirurgische Pinzetten  
 Dressing forceps, Tissue forceps  
 Pinzas de disección, Pinzas de disección con dientes  
 Pincès à dissection, Pincès à griffes  
 Pinze anatomiche per dissezione, Pinze chirurgiche a denti di topo

AA

AB

AC

AD

AE

AF

AK

AL

AO

KA

KK

X

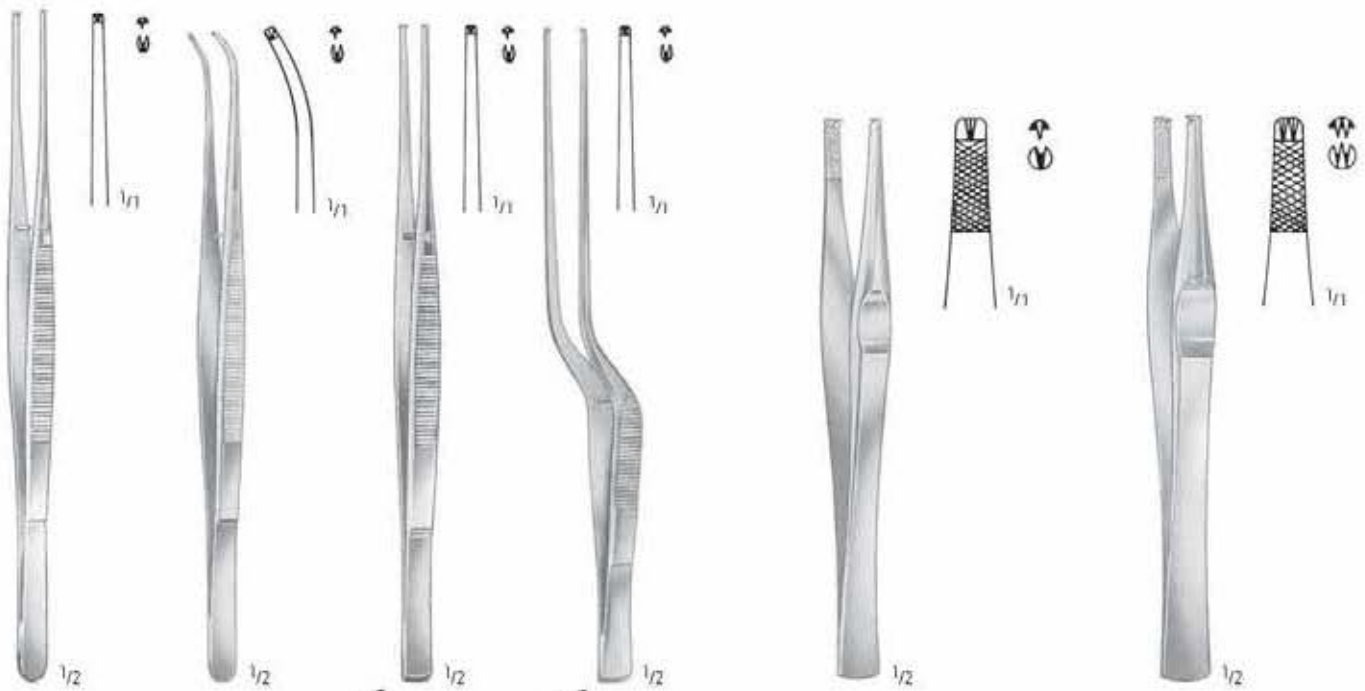

**TAYLOR**  
**1:2**  
 AB 150/17  
 17,5 cm/7"

**TAYLOR**  
**1:2**  
 AB 151/17  
 17,5 cm/7"

**TAYLOR**  
**1:2**  
 AB 152/17  
 17,5 cm/7"

**TAYLOR**  
**1:2**  
 AB 153/17  
 17,5 cm/7"

**LANE**  
**1:2**  
 AB 156/14 14,5 cm/5<sup>3</sup>/<sub>4</sub>"  
 AB 156/20 20,0 cm/8"

**LANE**  
**2:3**  
 AB 158/14  
 AB 158/20

**AB** PINZETTEN FORCEPS PINZAS PINCES PINZE

Anatomische Pinzetten, Chirurgische Pinzetten  
 Dressing Forceps, Tissue Forceps  
 Pinzas de disección, Pinzas de disección con dientes  
 Pincés à dissection, Pincés à griffes  
 Pinze anatomiche per dissezione, Pinze chirurgiche a denti di topo



**GERALD**  
 AB 160/18 18,0 cm/7"



**GERALD**  
 AB 161/18



**GERALD 1:2**  
 AB 170/18 18,0 cm/7"



**GERALD 1:2**  
 AB 171/18



**CUSHING**  
 AB 180/17 17,5 cm/7"



**CUSHING**  
 AB 181/17



**CUSHING 1:2**  
 AB 190/17 17,5 cm/7"



**CUSHING 1:2**  
 AB 191/17



PINZETTEN FORCEPS PINZAS PINCES PINZE

Anatomische Pinzetten, Chirurgische Pinzetten  
 Dressing Forceps, Tissue Forceps  
 Pinzas de disección, Pinzas de disección con dientes  
 Pincés à dissection, Pincés à griffes  
 Pinze anatomiche per dissezione, Pinze chirurgiche a denti di topo

AA

AB

AC

AD

AE

AF

AK

AL

AO

KA

KK

X



AB 200/18

**POTTS-SMITH**



AB 201/18



AB 210/18

**POTTS-SMITH  
1:2**



AB 211/18

18,0 cm/7"  
 21,0 cm/8 1/4"  
 25,0 cm/10"

AB 200/18  
 AB 200/21  
 AB 200/25

AB 201/18  
 AB 201/21  
 AB 201/25

AB 210/18  
 AB 210/21  
 AB 210/25

AB 211/18  
 AB 211/21  
 AB 211/25



**BROPHY**



AB 251/20



**BROPHY  
1:2**

AB 260/20



AB 261/20

20,0 cm/8"

AB 250/20

**AB** PINZETTEN FORCEPS PINZAS PINCES PINZE

Mikro-Pinzetten, Knüpfpinzetten mit Plateau  
 Micro Forceps, Suture Tying forceps with platform  
 Micro-Pinzas, Pinzas de ligadura con plataforma  
 Micro-Pinces, Pinces à ligature avec plate-forme  
 Micro-Pinze, Pinze per ligature con piattaforma

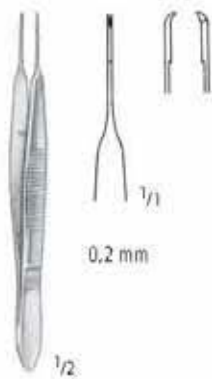

**1:2**  
 AB 530/09  
 9,5 cm/3<sup>3</sup>/<sub>4</sub>"



**AUSTIN**  
 AB 532/14  
 14,0 cm/5<sup>1</sup>/<sub>2</sub>"

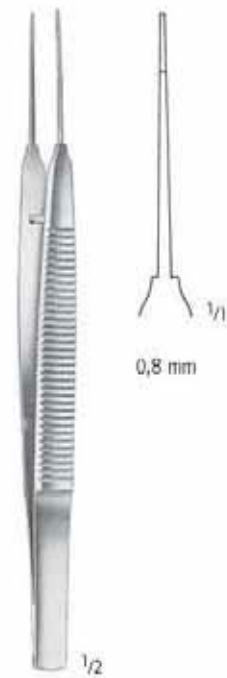

**AUSTIN**  
 AB 532/18  
 18,0 cm/7"

PINZETTEN FORCEPS PINZAS PINCES PINZE

Mikro-Pinzetten, Knüpfpinzetten mit Plateau, Gefäßdilator  
 Micro Forceps, Suture Tying Forceps with platform, Vessel Dilator  
 Micro-Pinzas, Pinzas de ligadura con plataforma, Dilatador para vasos  
 Micro-Pinces, Pinces à ligature avec plate-forme, Dilatateur pour vaisseaux  
 Micro-Pinze, Pinze per ligature con piattaforma, Dilatatore per vasi

AA  
 AB  
 AC  
 AD  
 AE  
 AF  
 AG  
 AH  
 AI  
 AJ  
 AK  
 AL  
 AM  
 AN  
 AO  
 AP  
 AQ  
 AR  
 AS  
 AT  
 AU  
 AV  
 AW  
 AX



AB 536/14  
 14,0 cm/5 1/2"



AB 538/14 1:2  
 14,0 cm/5 1/2"



AB 540/14 1:2  
 14,0 cm/5 1/2"

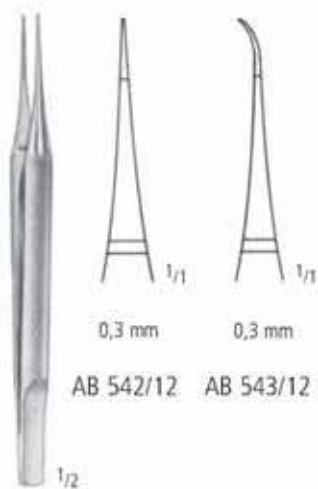

12,0 cm/4 3/4" AB 542/12 AB 543/12  
 15,0 cm/6" AB 542/15 AB 543/15



18,0 cm/7"



AB 546/11  
 11,0 cm/4 1/3"

**AB** PINZETTEN FORCEPS PINZAS PINCES PINZE

Atraumatische Pinzetten  
 Non-traumatic Vascular Tissue Forceps  
 Pinzas Atrauma  
 Pincas Atrauma  
 Pinze Atrauma

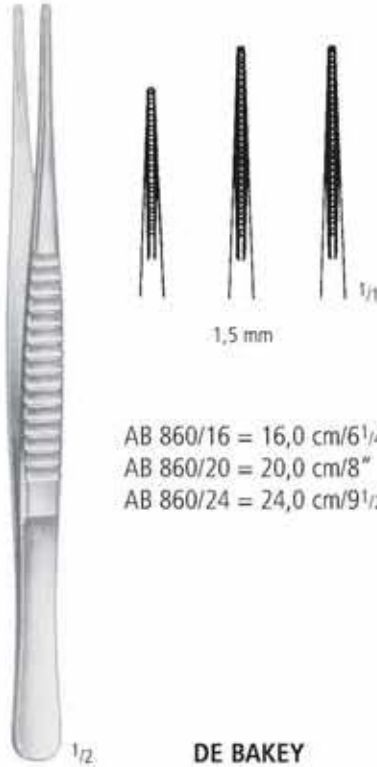

1,5 mm

AB 860/16 = 16,0 cm/6<sup>1</sup>/<sub>4</sub>"  
 AB 860/20 = 20,0 cm/8"  
 AB 860/24 = 24,0 cm/9<sup>1</sup>/<sub>2</sub>"

**DE BAKAY**

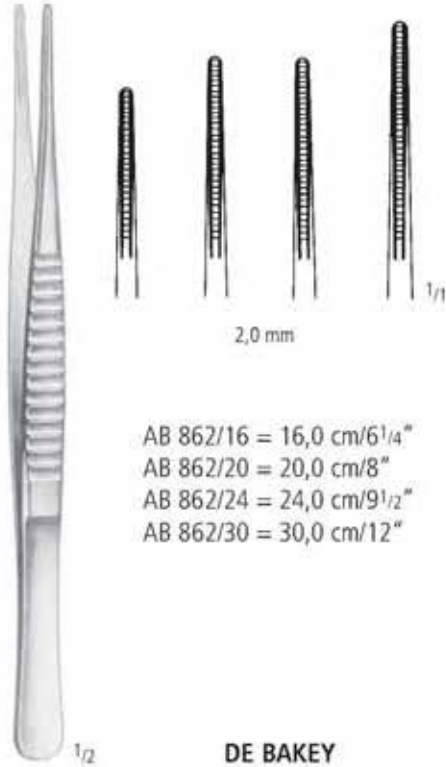

2,0 mm

AB 862/16 = 16,0 cm/6<sup>1</sup>/<sub>4</sub>"  
 AB 862/20 = 20,0 cm/8"  
 AB 862/24 = 24,0 cm/9<sup>1</sup>/<sub>2</sub>"  
 AB 862/30 = 30,0 cm/12"

**DE BAKAY**

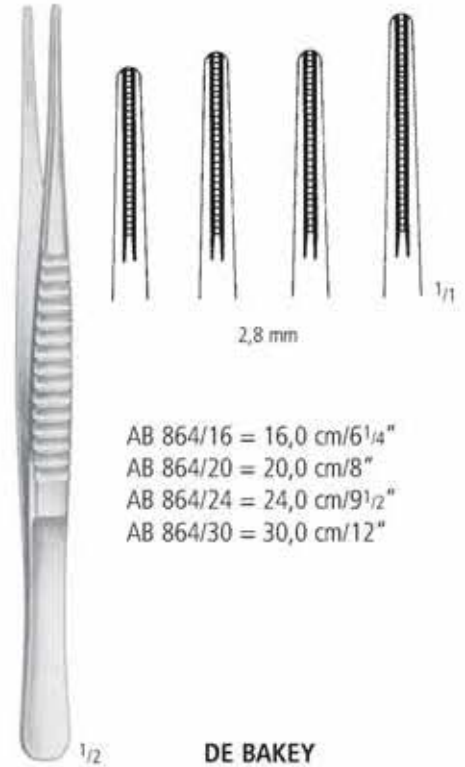

2,8 mm

AB 864/16 = 16,0 cm/6<sup>1</sup>/<sub>4</sub>"  
 AB 864/20 = 20,0 cm/8"  
 AB 864/24 = 24,0 cm/9<sup>1</sup>/<sub>2</sub>"  
 AB 864/30 = 30,0 cm/12"

**DE BAKAY**

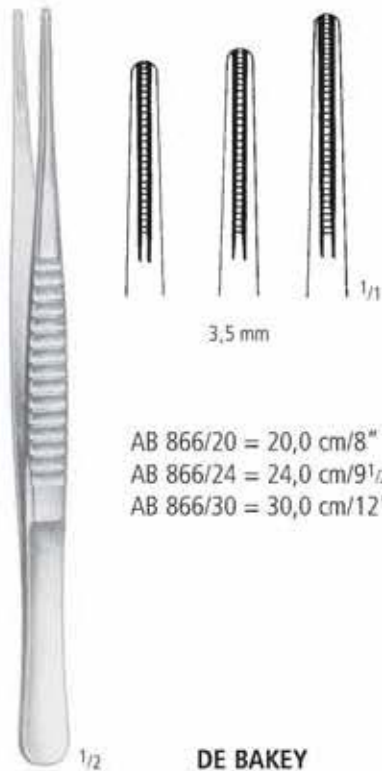

3,5 mm

AB 866/20 = 20,0 cm/8"  
 AB 866/24 = 24,0 cm/9<sup>1</sup>/<sub>2</sub>"  
 AB 866/30 = 30,0 cm/12"

**DE BAKAY**

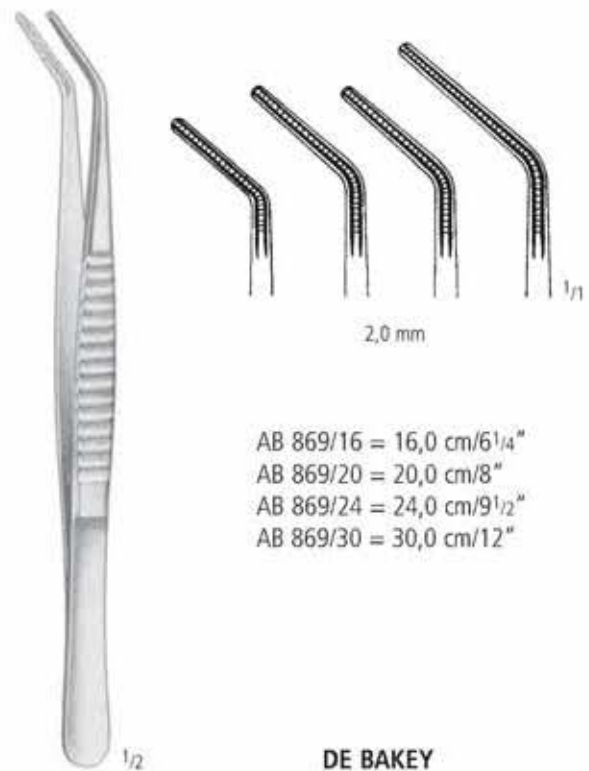

2,0 mm

AB 869/16 = 16,0 cm/6<sup>1</sup>/<sub>4</sub>"  
 AB 869/20 = 20,0 cm/8"  
 AB 869/24 = 24,0 cm/9<sup>1</sup>/<sub>2</sub>"  
 AB 869/30 = 30,0 cm/12"

**DE BAKAY**

PINZETTEN FORCEPS PINZAS PINCES PINZE

Pinzetten mit Hartmetalleinsätzen  
 Dissecting forceps with Tungsten Carbide Inserts  
 Pinzas de disección con bocas de carburo de tungsteno  
 Pincers à dissection avec mors en carbure de tungstène  
 Pinze per dissezione con punte di carburo di tungsteno

AA

AB

AC

AD

AE

AF

AK

AL

AO

KA

KK

X



POTTS-SMITH



AB 880/15  
15,0 cm/6"



AB 880/18  
18,0 cm/7"



AB 880/20  
20,0 cm/8"



AB 880/23  
23,0 cm/9"



AB 880/25  
25,0 cm/10"



OEHLER 1:2



AB 882/14  
14,0 cm/5 1/2"



AB 882/16  
16,0 cm/6 1/4"



AB 882/18  
18,0 cm/7"



AB 882/20  
20,0 cm/8"



AB 882/25  
25,0 cm/10"



AB 882/30  
30,0 cm/12"



SEMKEN  
AB 890/12  
AB 890/15



AB 890/12

12,5 cm/5"  
15,5 cm/6"



GILLIES 1:2  
AB 900/15



15,0 cm/6"



JEWELER  
AB 902/15



15,0 cm/6"



Pinzetten mit Hartmetalleinsätzen  
 Dissecting Forceps with Tungsten Carbide Inserts  
 Pinzas de disección con bocas de carburo de tungsteno  
 Pincès à dissection avec mors en carbure de tungstène  
 Pinze per dissezione con punte di carburo di tungsteno

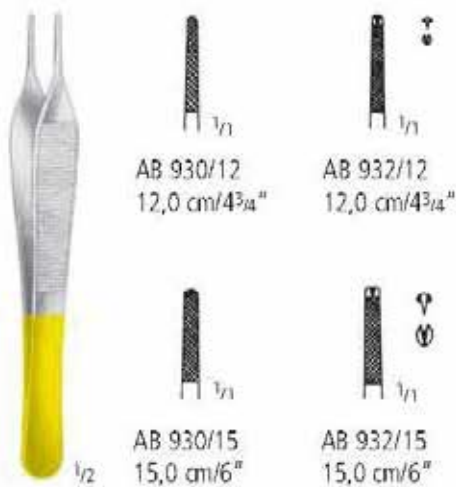

**ADSON**



**CUSHING**  
17,5 cm/7"

**CUSHING-TAYLOR**  
AB 943/18  
18,0 cm/7"

PINZETTEN FORCEPS PINZAS PINCES PINZE

Pinzetten mit Hartmetalleinsätzen  
 Dissecting Forceps with Tungsten Carbide Inserts  
 Pinzas de disección con bocas de carburo de tungsteno  
 Pincès à dissection avec mors en carbure de tungstène  
 Pinze per dissezione con punte di carburo di tungsteno



**DE BAKEY**  
 16,0 cm/6<sup>1</sup>/<sub>4</sub>"      1,5 mm      2,0 mm  
 20,0 cm/8"      AB 944/16      AB 946/16  
 24,0 cm/9<sup>1</sup>/<sub>2</sub>"      AB 944/20      AB 946/20  
                          AB 944/24      AB 946/24



**BONNEY 1:2**  
 AB 948/18  
 18,0 cm/7"



**WANGENSTEEN**

AB 950/15  
 15,0 cm/6"

AB 950/23  
 23,0 cm/9"

AA  
 AB  
 AC  
 AD  
 AE  
 AF  
 AK  
 AL  
 AO  
 KA  
 KK  
 X

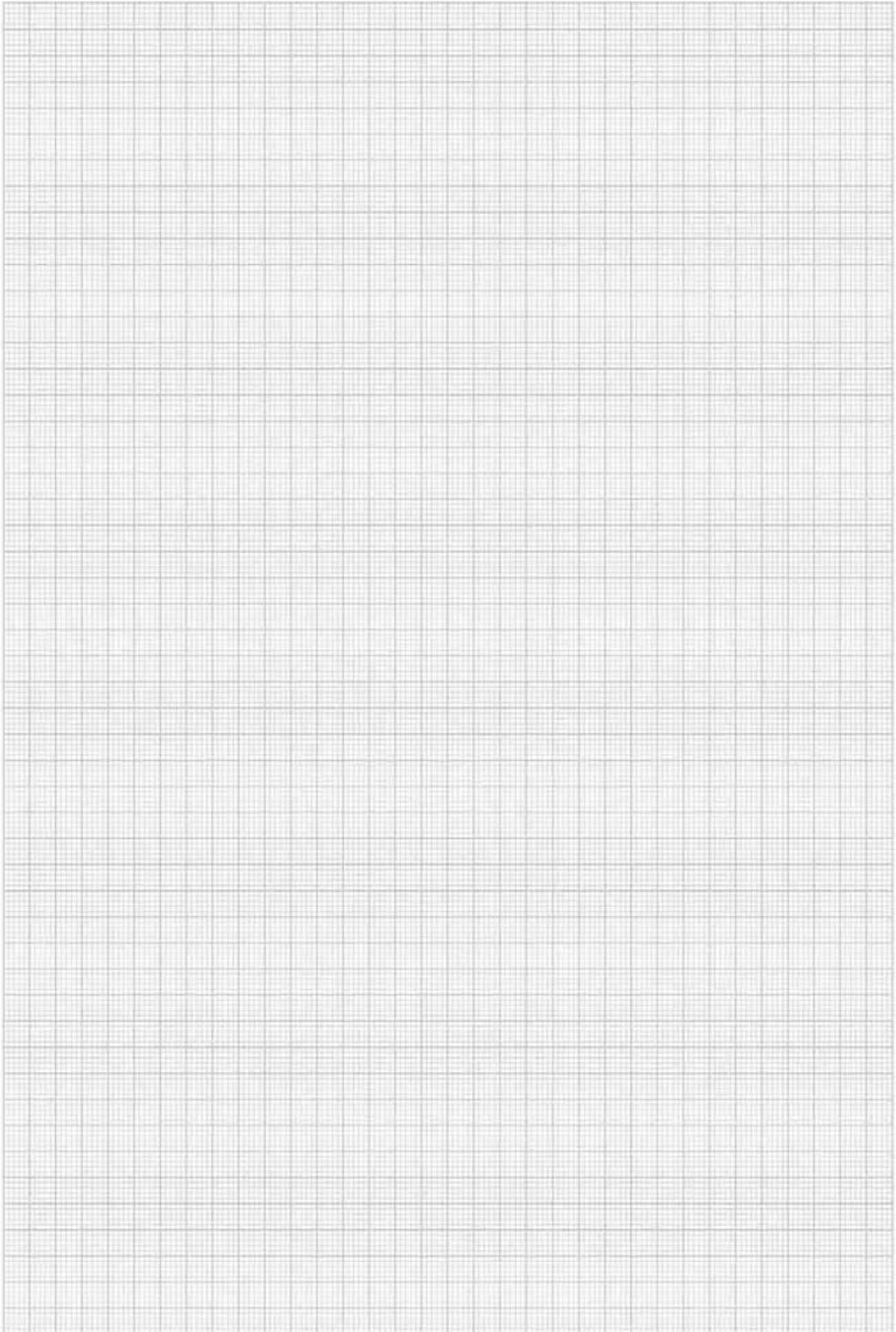

SCHEREN  
SCISSORS  
TIJERAS  
CISEAUX  
FORBICI

AC

nopa<sup>®</sup> instruments

Weitere Scheren finden Sie in unserem Katalog  
"Allgemeine Chirurgie" in Gruppe AC.

For further scissors kindly refer to our catalogue  
"General Surgery", section AC.

Para tijeras adicionales, por favor consulte nuestro  
catálogo de "Cirugía general", grupo AC.

Pour des ciseaux supplémentaires, consultez notre  
catalogue "Chirurgie Generale", section AC.

Per gli altri forbici, consultare il nostro catalogo  
"Chirurgia Generale", gruppo AC.







nopa® SC  
**SUPER CUT**



**SUPER CUT**

#### Besonderheit:

**nopa Super Cut** Scheren haben eine rasierklingenscharfe Schneide, kombiniert mit einer mikrogezahnten Schneide.

>> Diese Scheren sind durch schwarze Ringe gekennzeichnet.

#### Features:

**nopa Super Cut** scissors have a razor-like edge combined with one micro serrated blade.

>> Black rings for easy identification.

#### Verfügbare Modelle / Available Patterns

Im Katalog durch \* markiert. / Marked in catalog with \*.

- AC 110/18 SC METZENBAUM-NELSON SCS STR. BL/BL 18,0 CM SC
- AC 110/20 SC METZENBAUM-NELSON SCS STR. BL/BL 20,0 CM SC
- AC 110/23 SC METZENBAUM-NELSON SCS STR. BL/BL 23,0 CM SC
- AC 111/18 SC METZENBAUM-NELSON SCS CVD. BL/BL 18,0 CM SC
- AC 111/20 SC METZENBAUM-NELSON SCS CVD. BL/BL 20,0 CM SC
- AC 111/23 SC METZENBAUM-NELSON SCS CVD. BL/BL 23,0 CM SC
- AC 141/14 SC METZENBAUM-DELICATE SCS BL/BL CVD. 14,5 CM SC
- AC 151/18 SC METZENBAUM-DELICATE SCS BL/BL CVD. 18,0 CM SC
- AC 214/15 SC REYNOLDS DISS. SCS STR. SH/SH 15,0 CM SC
- AC 214/18 SC REYNOLDS DISS. SCS CVD. SH/SH 18,0 CM SC
- AC 450/11 SC IRIS SCS STR. SH/SH 11,5 CM SC
- AC 451/11 SC IRIS SCS CVD. SH/SH 11,5 CM SC
- AC 476/11 SC STEVENS TENOTOMY SCS STR. BL/BL 11,5 CM SC
- AC 477/11 SC STEVENS TENOTOMY SCS CVD. BL/BL 11,5 CM SC





titan instruments

# nopa<sup>®</sup> instruments

## Besonderheit:

nopa Titan Instrumente bieten insbesondere in der Herz-Thorax-Chirurgie Vorteile gegenüber herkömmlichen Instrumenten. Titan ist ca. 45% leichter als rostfreier Edelstahl, weshalb Titan Instrumente weniger traumatisierend sind. Titan ist außerdem ein vollkommen korrosionsbeständiges und antimagnetisches Material. nopa Titan Instrumente bedeuten größtmöglichen Komfort für den Chirurgen.

## Features:

nopa Titan Instruments provide especially in Cardiovascular surgery a significant advantage compared to other Instruments. Titan is approximately 45% lighter than stainless steel. For that reason, Titan Instruments are less traumatic. Besides that, Titan is a completely stainless and anti-magnetic material. nopa Titan Instruments are the most comfortable choice for the Cardiovascular surgeon.

AC 870/11 T	MICRO SCISSORS 18,0 CM, 25°
AC 870/12 T	MICRO SCISSORS 18,0 CM, 45°
AC 870/13 T	MICRO SCISSORS 18,0 CM, 60°
AC 870/14 T	MICRO SCISSORS 18,0 CM, 90°
AC 870/15 T	MICRO SCISSORS 18,0 CM, 125°
AC 871/11 T	MICRO SCISSORS 18,0 CM, 25°
AC 871/12 T	MICRO SCISSORS 18,0 CM, 45°
AC 871/13 T	MICRO SCISSORS 18,0 CM, 60°
AC 871/14 T	MICRO SCISSORS 18,0 CM, 90°
AC 871/15 T	MICRO SCISSORS 18,0 CM, 125°





SCHEREN SCISSORS TIJERAS CISEAUX FORBICI

Präparierscheren  
Dissecting Scissors  
Tijeras para preparaciones  
Ciseaux à dissection  
Forbici per preparazioni



**METZENBAUM-NELSON**



**METZENBAUM-NELSON**



Fig. 1



Fig. 2



Fig. 3

18,0 cm/7"	AC 110/18*	AC 111/18*	AC 120/18	AC 121/18	AC 130/18	AC 131/18
20,0 cm/8"	AC 110/20*	AC 111/20*	AC 120/20	AC 121/20	AC 130/20	AC 131/20
23,0 cm/9"	AC 110/23*	AC 111/23*	AC 120/23	AC 121/23	AC 130/23	AC 131/23
25,0 cm/10"	AC 110/25	AC 111/25	AC 120/25	AC 121/25	AC 130/25	AC 131/25
28,0 cm/11"	AC 110/28	AC 111/28	AC 120/28	AC 121/28	AC 130/28	AC 131/28
30,0 cm/12"	AC 110/30	AC 111/30	AC 120/30	AC 121/30	AC 130/30	AC 131/30



Präparierscheren, DELICATE  
 Dissecting Scissors, DELICATE  
 Tijeras para preparaciones, DELICATE  
 Ciseaux à dissection, DELICATE  
 Forbici per preparazioni, DELICATE

METZENBAUM-DELICATE

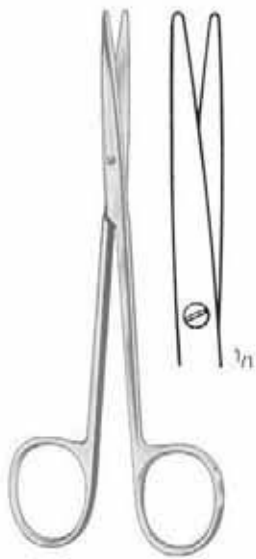

Fig. 1  
 AC 140/14  
 14,5 cm/5<sup>3</sup>/<sub>4</sub>"



Fig. 1  
 AC 141/14\*  
 14,5 cm/5<sup>3</sup>/<sub>4</sub>"



Fig. 3  
 AC 142/14  
 14,5 cm/5<sup>3</sup>/<sub>4</sub>"

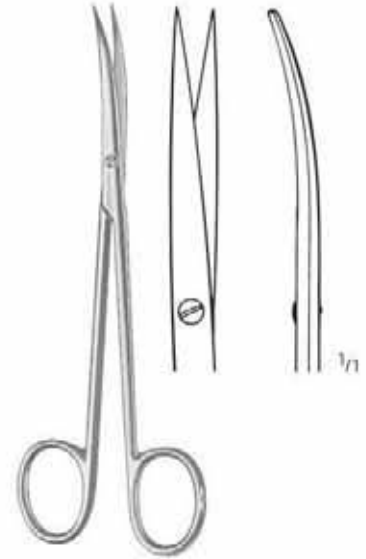

Fig. 3  
 AC 143/14  
 14,5 cm/5<sup>3</sup>/<sub>4</sub>"

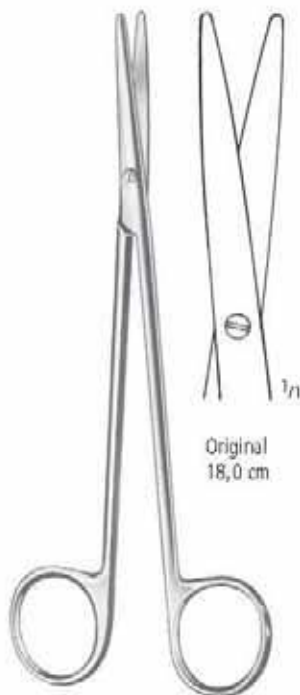

Fig. 1

Original  
 18,0 cm



Fig. 1

Original  
 18,0 cm

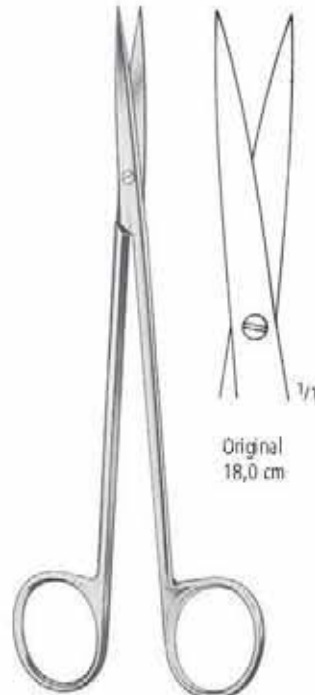

Fig. 3

Original  
 18,0 cm

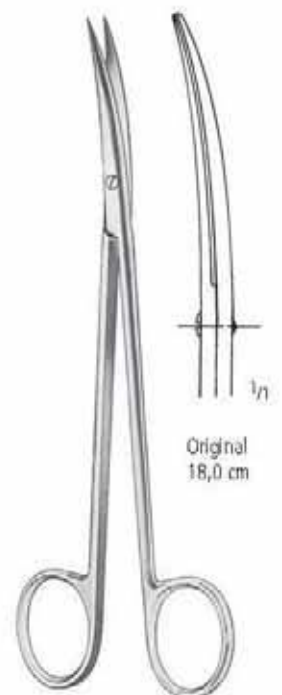

Fig. 3

Original  
 18,0 cm

18,0 cm/7"	AC 150/18	AC 151/18*	AC 152/18	AC 153/18
20,0 cm/8"	AC 150/20	AC 151/20	AC 152/20	AC 153/20
23,0 cm/9"	AC 150/23	AC 151/23	AC 152/23	AC 153/23
25,0 cm/10"			AC 152/25	AC 153/25
28,0 cm/11"			AC 152/28	AC 153/28
30,0 cm/12"			AC 152/30	AC 153/30

SCHEREN SCISSORS TIJERAS CISEAUX FORBICI

Präparierscheren  
Dissecting Scissors  
Tijeras para preparaciones  
Ciseaux à dissection  
Forbici per preparazioni

AA  
AB  
AC  
AD  
AE  
AF  
AK  
AL  
AO  
KA  
KK  
X

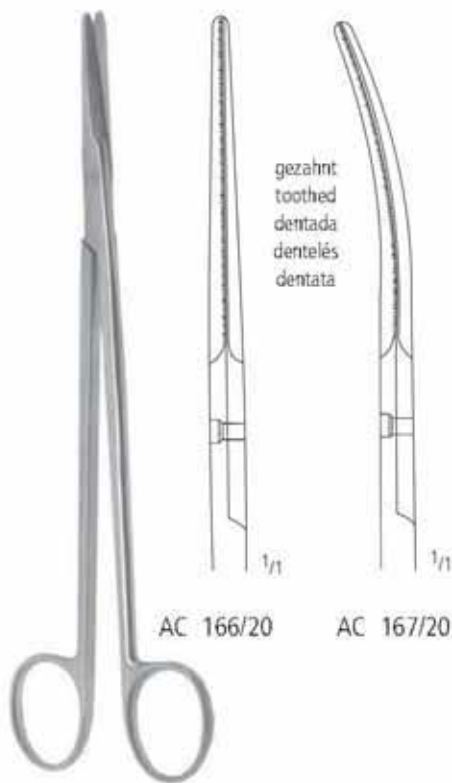

**GORNEY**  
19,5 cm/7<sup>3</sup>/<sub>4</sub>"

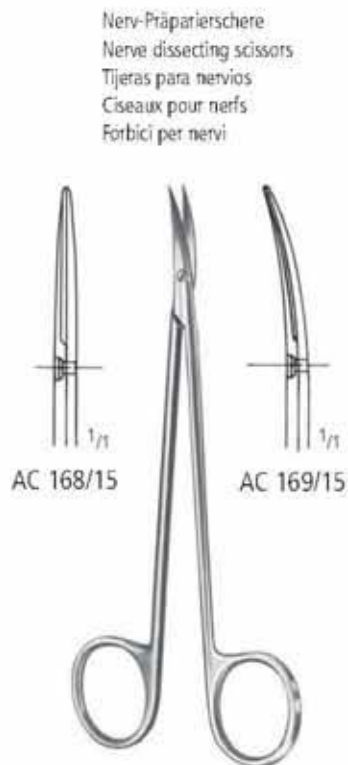

15,0 cm/6"



**LEXER**  
AC 170/16  
16,0 cm/6<sup>1</sup>/<sub>4</sub>"



**LEXER**  
AC 171/16  
16,0 cm/6<sup>1</sup>/<sub>4</sub>"

**AC** SCHEREN SCISSORS TIJERAS CISEAUX FORBICI

Präparierscheren  
Dissecting Scissors  
Tijeras para preparaciones  
Ciseaux à dissection  
Forbici per preparazioni



**SANVENERO**

AC 200/14  
14,0 cm/5 1/2"

AC 201/14  
14,0 cm/5 1/2"

**JOSEPH**

AC 204/14  
14,0 cm/5 1/2"

AC 205/14  
14,0 cm/5 1/2"



**KILNER (RAGNELL)**

AC 208/12	12,0 cm/4 3/4"	AC 210/12
AC 208/15	15,0 cm/6"	AC 210/15
AC 208/18	18,0 cm/7"	AC 210/18
AC 208/20	20,0 cm/8"	AC 210/20

**REYNOLDS**

AC 214/15*	15,0 cm/6"	AC 215/15
AC 214/18*	18,0 cm/7"	AC 215/18

SCHEREN SCISSORS TIJERAS CISEAUX FORBICI

Scheren für Gefäß-Chirurgie  
 Scissors for Vascular Surgery  
 Tijeras para cirugía vasculares  
 Ciseaux pour chirurgie vasculaire  
 Forbici per chirurgia vascolare

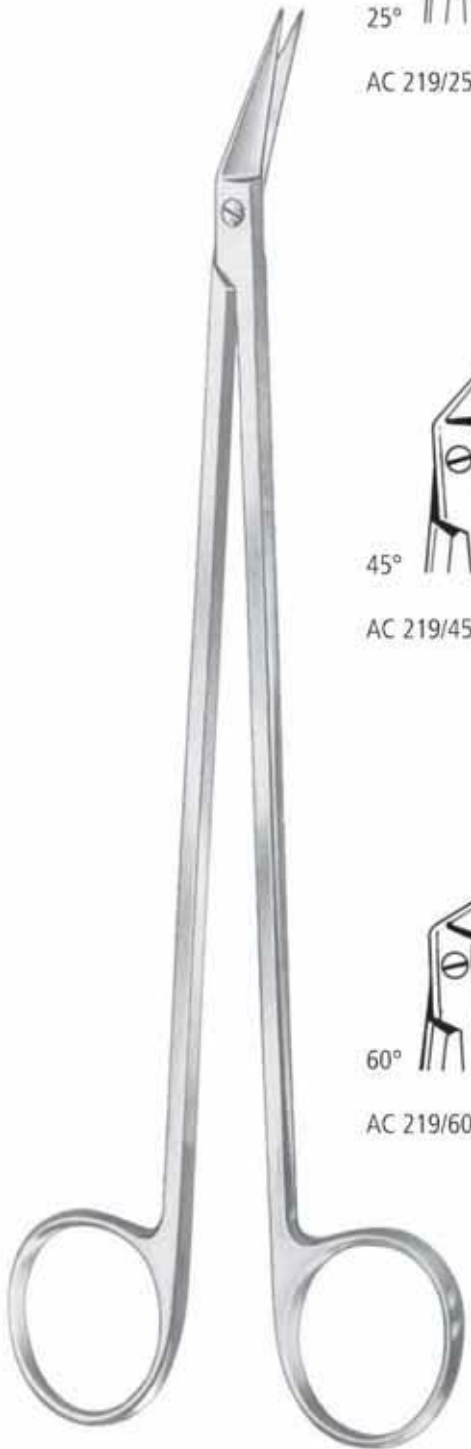

25°

AC 219/25



45°

AC 219/45



60°

AC 219/60



**POTT-SMITH**  
 19,0 cm/7 1/2"



25°

AC 220/16 16,0 cm/6 1/4"  
 AC 220/19 19,0 cm/7 1/2"  
 AC 220/23 23,0 cm/9"  
 AC 220/28 28,0 cm/11"



45°

AC 221/16 16,0 cm/6 1/4"  
 AC 221/19 19,0 cm/7 1/2"  
 AC 221/23 23,0 cm/9"  
 AC 221/28 28,0 cm/11"

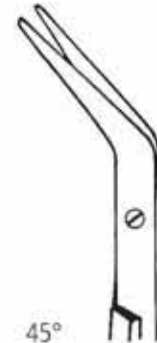

60°



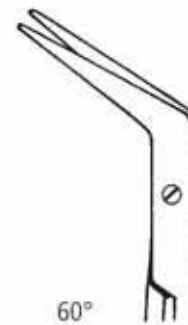

AC 222/16 16,0 cm/6 1/4"  
 AC 222/19 19,0 cm/7 1/2"  
 AC 222/23 23,0 cm/9"  
 AC 222/28 28,0 cm/11"



**DE BAKEY**

AA  
 AB  
 AC  
 AD  
 AE  
 AF  
 AK  
 AL  
 AO  
 KA  
 KK  
 X

Scheren für Gefäß-Chirurgie  
 Scissors for Vascular Surgery  
 Tijeras para cirugía vasculares  
 Ciseaux pour chirurgie vasculaire  
 Forbici per chirurgia vascolare

		25° AC 223/01 AC 224/01	18,0 cm/7" 19,0 cm/7 1/2"	
		45° AC 223/02 AC 224/02	18,0 cm/7" 19,0 cm/7 1/2"	
		60° AC 223/03 AC 224/03	17,5 cm/7" 19,0 cm/7 1/2"	
		90° AC 223/04 AC 224/04	17,0 cm/6 3/4" 19,0 cm/7 1/2"	
		125° AC 223/05 AC 224/05	17,0 cm/6 3/4" 19,0 cm/7 1/2"	
18,0 cm/7"		<b>HEGEMANN-DIETHRICH</b>		125°
				AC 225/19 19,0 cm/7 1/2"



SCHEREN SCISSORS TIJERAS CISEAUX FORBICI

Scheren für Gefäß- und Neurochirurgie  
 Scissors for Vascular and Neuro Surgery  
 Tijeras para cirugía vasculares y neurocirugía  
 Ciseaux pour chirurgie vasculaire et neurochirurgie  
 Forbici vascolari, Forbici per neurochirurgia

AA  
 AB  
 AC  
 AD  
 AE  
 AF  
 AK  
 AL  
 AO  
 KA  
 KK  
 X

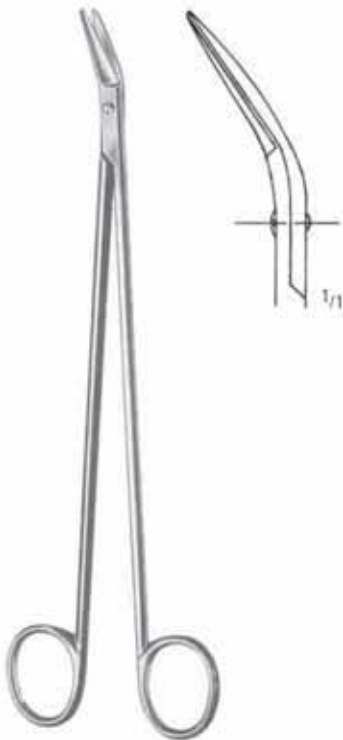

**POTTS-SMITH**  
 AC 227/19  
 19,5 cm/7<sup>3</sup>/<sub>4</sub>"

Coronar-Schere  
 Coronary-Scissors  
 Tijeras coronarias  
 Ciseaux coronaires  
 Forbici coronaria



AC 228/11  
 11,5 cm/4<sup>1</sup>/<sub>2</sub>"



AC 230/14  
 14,5 cm/5<sup>3</sup>/<sub>4</sub>"

geknöpft  
 probe pointed  
 con botón  
 boutonne  
 bottenuto



AC 231/22  
 22,0 cm/8<sup>3</sup>/<sub>4</sub>"

**STRULLY**



AC 232/22  
 22,0 cm/8<sup>3</sup>/<sub>4</sub>"



**DANDY**  
 AC 233/17  
 17,0 cm/6<sup>3</sup>/<sub>4</sub>"

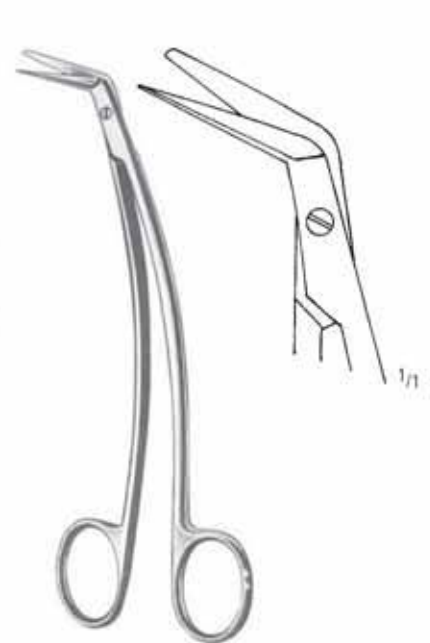

**FAVALORO**  
 AC 234/15  
 15,0 cm/6"

**AC** SCHEREN SCISSORS TIJERAS CISEAUX FORBICI

Scheren für Gefäß- und Neurochirurgie  
 Scissors for Vascular and Neuro Surgery  
 Tijeras para cirugía vasculares y neurocirugía  
 Ciseaux pour chirurgie vasculaire et neurochirurgie  
 Forbici vascolari, Forbici per neurochirurgia

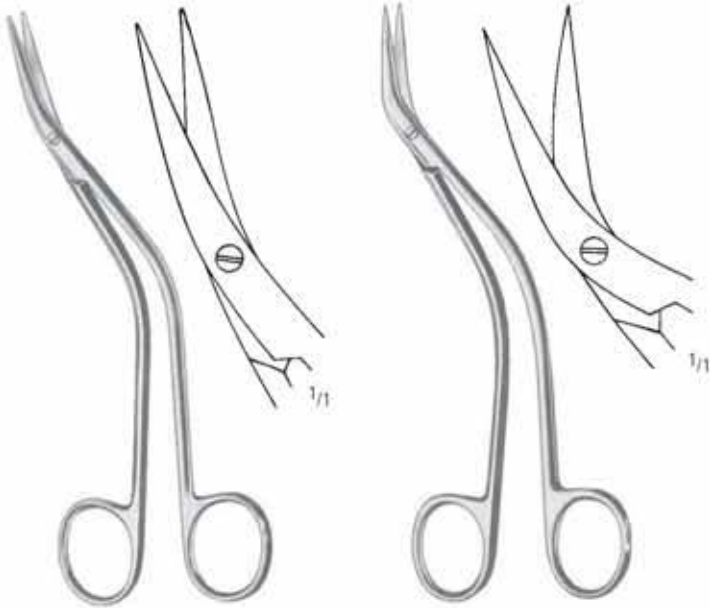

**DE BAKEY**

AC 235/15  
15,5 cm/6"

AC 236/15  
15,5 cm/6"



**POTTS-DE MARTEL**

AC 237/21  
21,0 cm/8<sup>1</sup>/<sub>4</sub>"

**MILLS**

AC 238/21  
21,0 cm/8<sup>1</sup>/<sub>4</sub>"



**SCHMIEDEN-TAYLOR**

14,5 cm/5<sup>1</sup>/<sub>2</sub>" AC 241/15  
17,0 cm/6<sup>3</sup>/<sub>4</sub>" AC 241/17

**TOENNIS-ADSON**

AC 247/17  
17,5 cm/7"

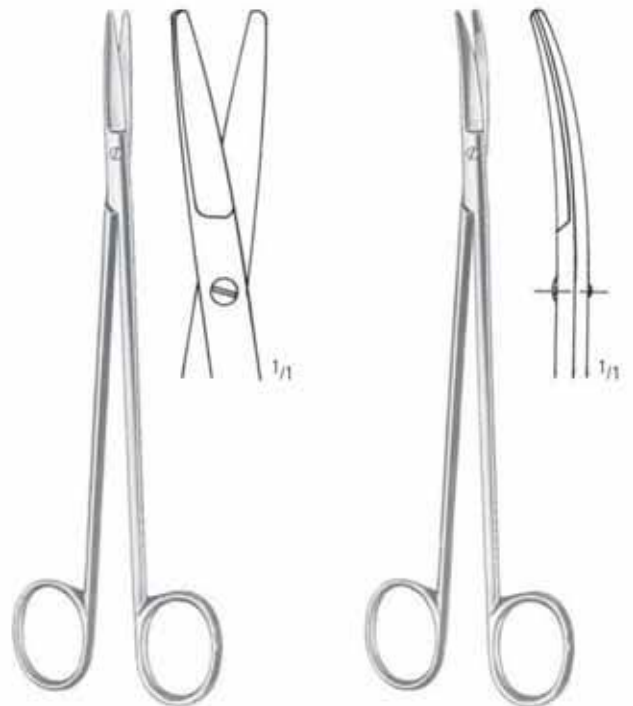

**TOENNIS**

AC 248/18  
18,0 cm/7"

AC 249/18  
18,0 cm/7"

SCHEREN SCISSORS TIJERAS CISEAUX FORBICI

Scheren für Gefäß- und Neurochirurgie  
 Scissors for Vascular and Neuro Surgery  
 Tijeras para cirugía vasculares y neurocirugía  
 Ciseaux pour chirurgie vasculaire et neurochirurgie  
 Forbici vascolari, Forbici per neurochirurgia

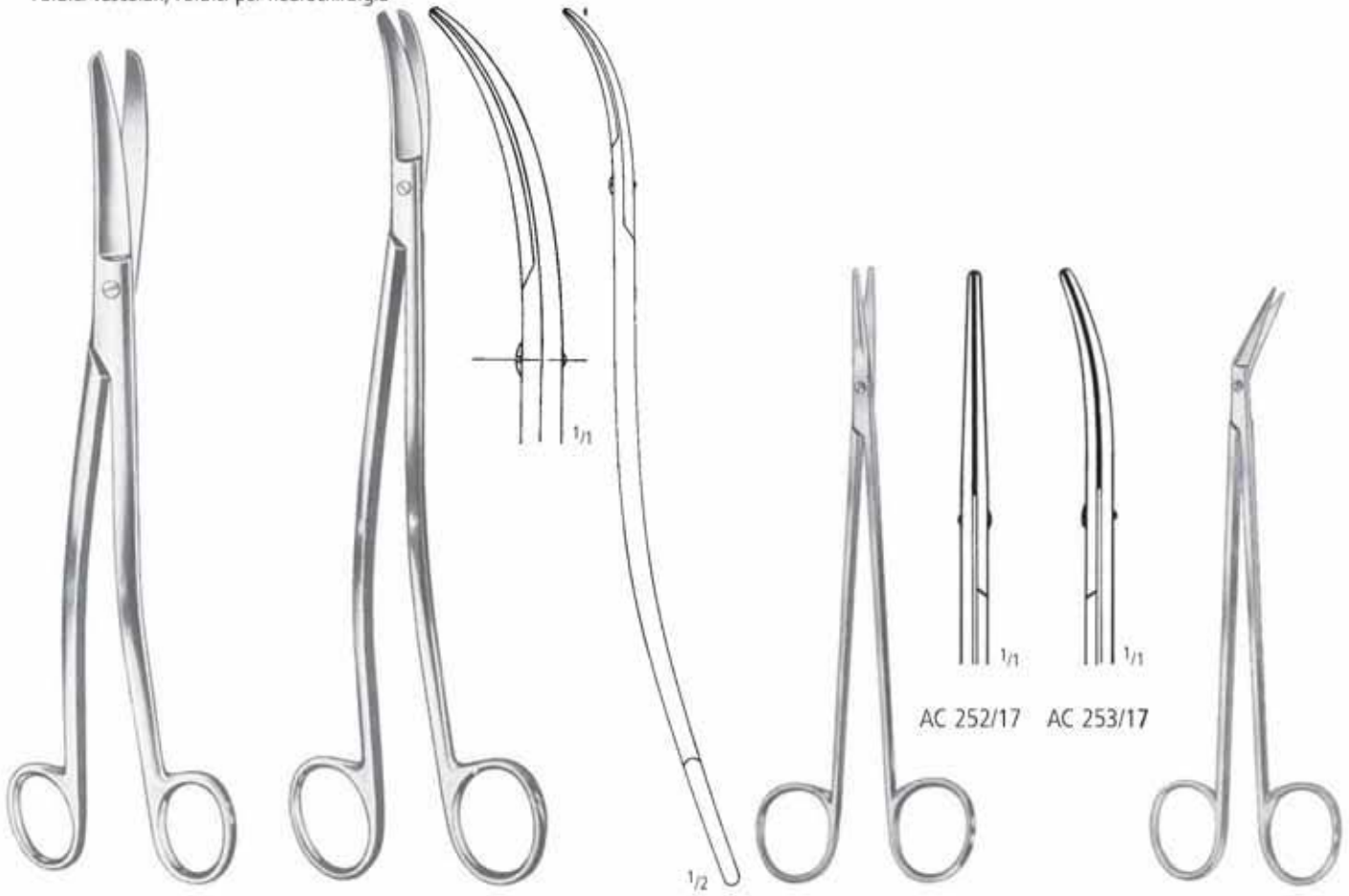

**KLINKENBERGH-LOTH**  
 AC 250/23  
 23,0 cm/9"

**SATINSKY**  
 AC 251/24  
 24,5 cm/9<sup>3</sup>/<sub>4</sub>"

**LINCOLN**  
 17,0 cm/6<sup>3</sup>/<sub>4</sub>"

**FULTON**  
 AC 255/17  
 17,0 cm/6<sup>3</sup>/<sub>4</sub>"



**CHURCH**  
 17,0 cm/6<sup>3</sup>/<sub>4</sub>"



**CLASSON**  
 AC 258/17  
 17,0 cm/6<sup>3</sup>/<sub>4</sub>"

AA  
 AB  
 AC  
 AD  
 AE  
 AF  
 AG  
 AH  
 AI  
 AJ  
 AK  
 AL  
 AM  
 AN  
 AO  
 AP  
 AQ  
 AR  
 AS  
 AT  
 AU  
 AV  
 AW  
 AX

**AC** SCHEREN SCISSORS TIJERAS CISEAUX FORBICI

Knorpel-, Lungenlappen-, Darm- und Anatomiescheren  
 Cartilage-, Lobectomy-, Enterotomy- and Dissecting Scissors  
 Tijeras para cartilago, lobectomia, enterótomos y disección  
 Ciseaux pour le cartilage, à lobectomie, à épisiotomie et à préparation  
 Forbici per cartilagini, lobectomia, episiotomia e anatomia

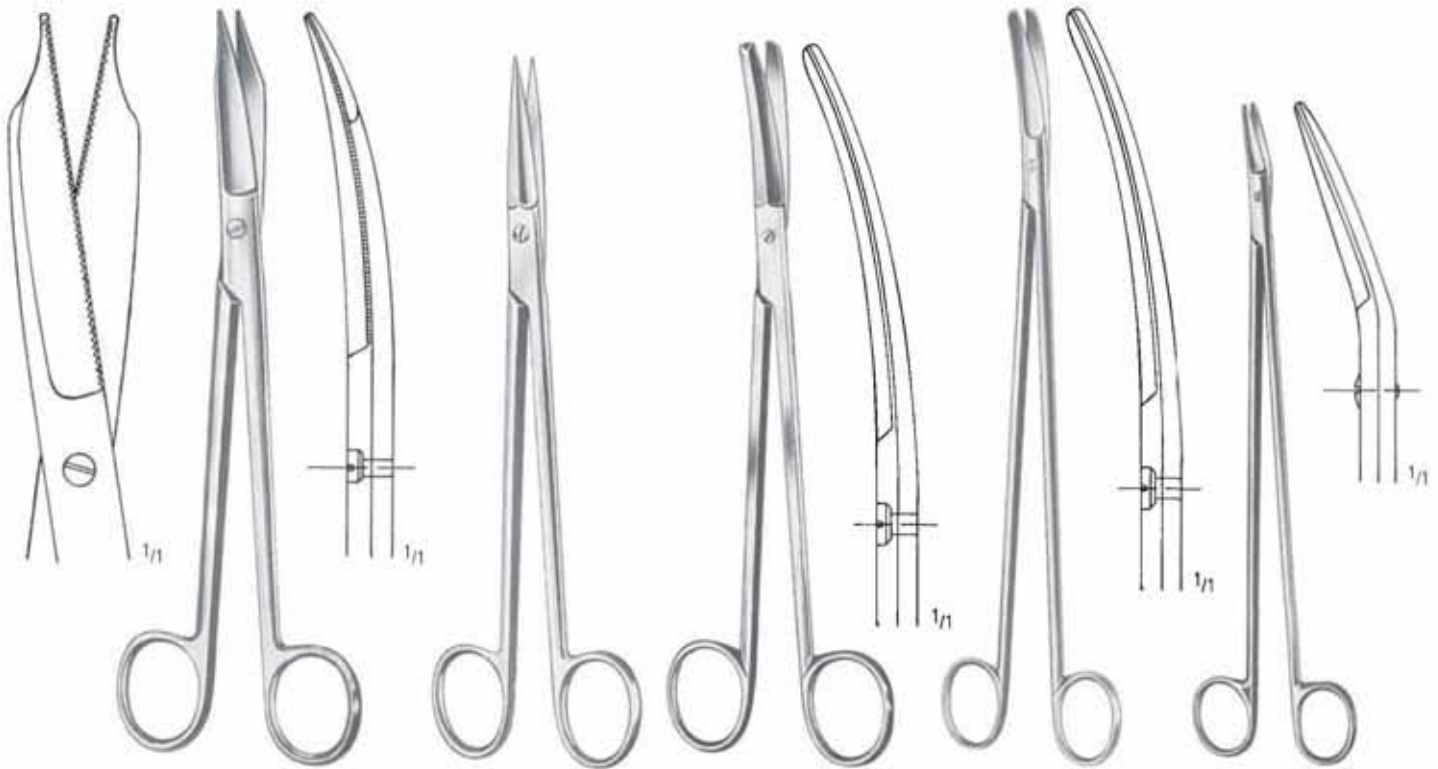

**MARTIN-CARTILAGE**  
 AC 275/20  
 20,0 cm/8"

**MC INDOE**  
 AC 276/19  
 19,0 cm/7½"

**POTTS-SMITH**  
 AC 277/19  
 19,0 cm/7½"

**CRAFOORD**  
 AC 280/30  
 30,0 cm/12"

**FINOCHIETTO**  
 AC 281/27  
 27,0 cm/10¾"

SCHEREN SCISSORS TIJERAS CISEAUX FORBICI

Feine Scheren  
Fine Scissors  
Tijeras finas  
Ciseaux fins  
Forbici fini

AA  
AB  
AC  
AD  
AE  
AF  
AK  
AL  
AO  
KA  
KK  
X

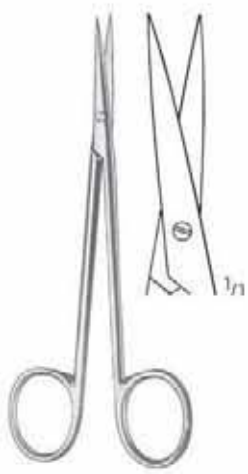

AC 410/11  
11,5 cm/4 1/2"



AC 411/11  
11,5 cm/4 1/2"

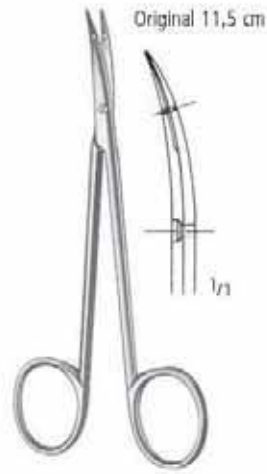

**LITTLER**  
AC 412/11 11,5 cm/4 1/2"  
AC 412/14 14,0 cm/5 1/2"

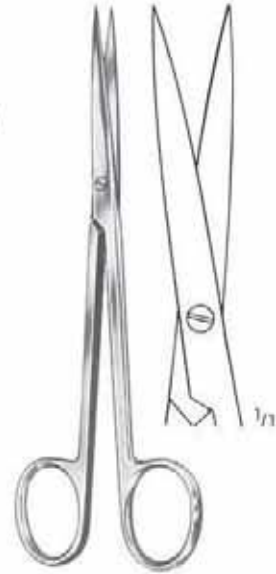

**BROPHY (SULLIVAN)**  
AC 414/14  
14,5 cm/5 3/4"



AC 415/14  
14,5 cm/5 3/4"

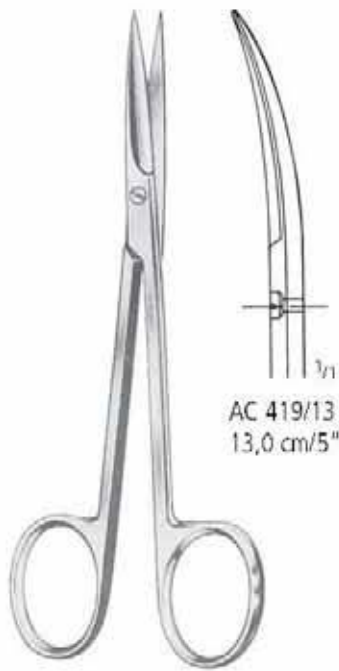

AC 418/13  
13,0 cm/5"

AC 419/13  
13,0 cm/5"



AC 422/10  
AC 422/11

10,5 cm/4 1/4"  
11,5 cm/4 1/2"



AC 423/10  
AC 423/11



AC 424/11  
11,5 cm/4 1/2"



**AC** SCHEREN SCISSORS TIJERAS CISEAUX FORBICI

Feine Scheren  
Fine Scissors  
Tijeras finas  
Ciseaux fins  
Forbici fini

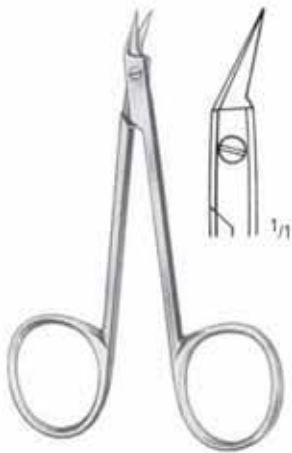

**O'BRIEN**  
AC 427/09  
9,0 cm/3 1/2"



**WALTON**  
AC 429/10  
10,0 cm/4"

sehr fein  
extra delicate  
muy finas  
très fin  
molto sottile



AC 430/08  
8,0 cm/3"

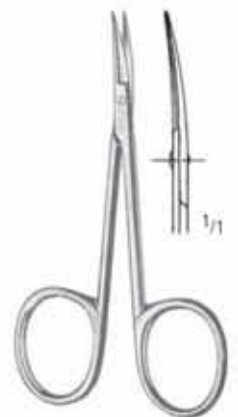

**MOD. BONN**  
AC 431/08  
8,0 cm/3"



**LANDOLT**  
AC 434/12  
12,5 cm/5"



**LANDOLT**  
AC 435/12  
12,5 cm/5"



**LANDOLT**  
AC 436/12  
12,5 cm/5"



**LANDOLT**  
AC 437/12  
12,5 cm/5"

SCHEREN SCISSORS TIJERAS CISEAUX FORBICI

Feine Scheren  
Fine Scissors  
Tijeras finas  
Ciseaux fins  
Forbici fini

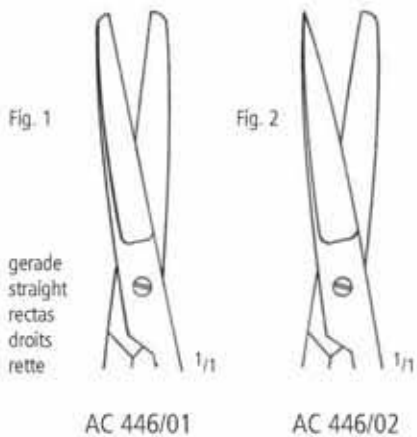

gerade  
straight  
rectas  
droits  
rette

AC 446/01

AC 446/02



11,5 cm/4 1/2"

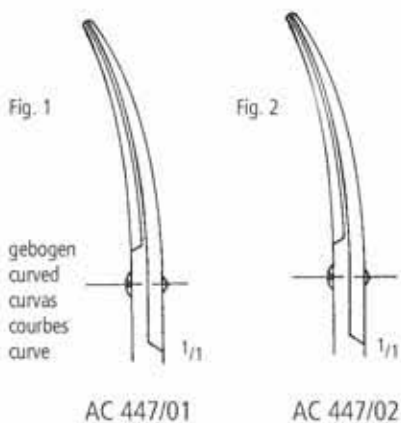

gebogen  
curved  
curvas  
courbes  
curve

AC 447/01

AC 447/02



AC 448/11  
11,5 cm/4 1/2"



AC 449/11  
11,5 cm/4 1/2"

Irisscheren  
Iris Scissors  
Tijeras para iridectomia  
Ciseaux à iridectomie  
Forbici per iridectomia



Original 10,5 cm

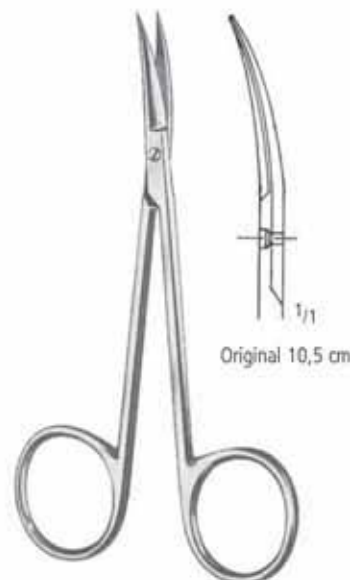

Original 10,5 cm

9,0 cm/3 1/2"	AC 450/09	AC 451/09
10,5 cm/4 1/4"	AC 450/10	AC 451/10
11,5 cm/4 1/2"	AC 450/11*	AC 451/11*

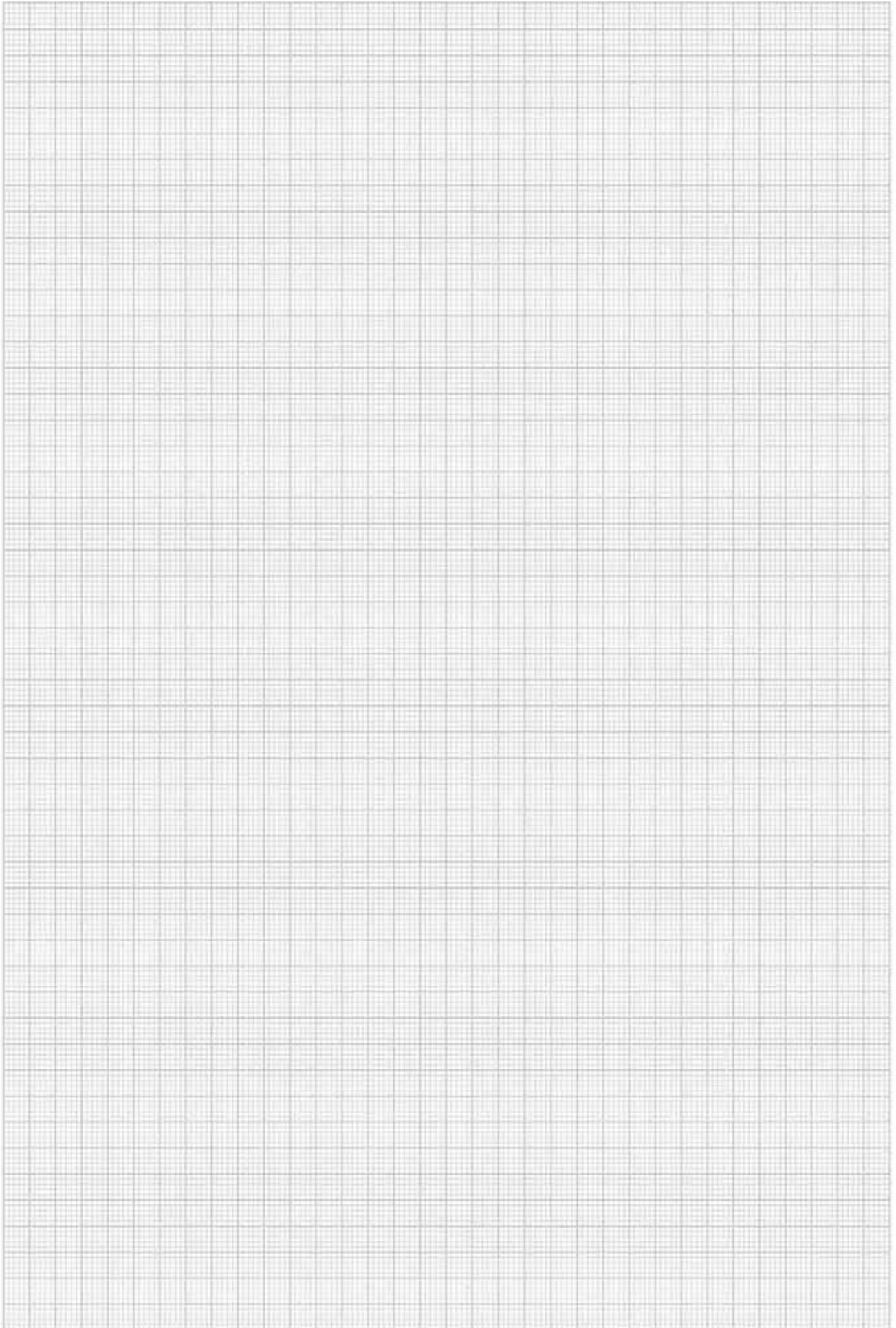

SCHEREN SCISSORS TIJERAS CISEAUX FORBICI

Feine Scheren  
Fine Scissors  
Tijeras finas  
Ciseaux fins  
Forbici fini

Schnenscheren  
Tenotomy Scissors  
Tijeras para tenotomía  
Ciseaux à ténatomie  
Forbici per tenotomia

Original 11,5 cm

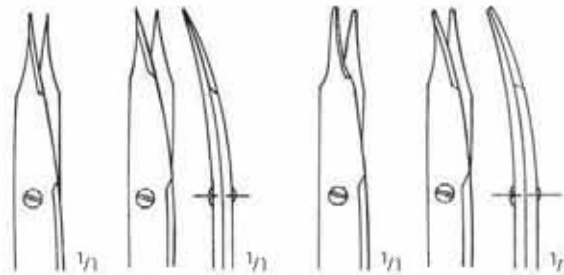

spitz  
pointed  
agudas  
pointues  
acuta

stumpf  
blunt  
romas  
mousses  
smussa

gerade  
straight  
rectas  
droits  
rette

gebogen  
curved  
curvas  
courbes  
curve

gerade  
straight  
rectas  
droits  
rette

gebogen  
curved  
curvas  
courbes  
curve

**STEVENS**

10,5 cm/4 1/4"  
11,5 cm/4 1/2"

AC 474/10  
AC 474/11

AC 475/10  
AC 475/11

AC 476/10  
AC 476/11\*

AC 477/10  
AC 477/11\*



**AC** SCHEREN SCISSORS TIJERAS CISEAUX FORBICI

Mikroscheren  
Micro Scissors  
Micro Tijeras  
Micro Ciseaux  
Micro Forbici

- >> Alle unsere Mikroscheren werden von Fachkräften mit jahrelanger Erfahrung hergestellt. Die Endkontrolle findet unter dem Mikroskop statt. Um Ihnen ein ermüdungsfreies Arbeiten zu ermöglichen, wird dem Federdruck größte Aufmerksamkeit gewidmet.
- >> Bitte wählen Sie unter Rund- oder Flachgriffscheren.

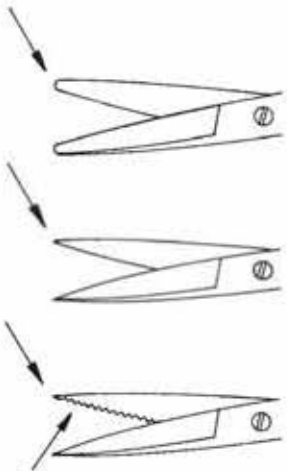

**Dissection:** **Gebogene Blätter, abgerundete Spitzen** ermöglichen eine gute und sichere Dissektion, ohne Nerven und Blutgefäße zu beschädigen.

**Adventitia:** **Gerade Blätter, sehr scharfe Spitzen** gewährleisten präzises Anfrischen von Gefäßenden.

**Nerve:** Ein Blatt ist **fein gezahnt**, um ein Herausgleiten des Nervs zu vermeiden.

- >> All our Micro Scissors are manufactured by skilled craftsmen with many years of experience. Final inspection is carried out under a microscope. Careful attention is paid to the closing pressure of the spring handle, to ensure precise work during surgeries, without fatigue.
- >> Round or flat handle scissors according to your preference.

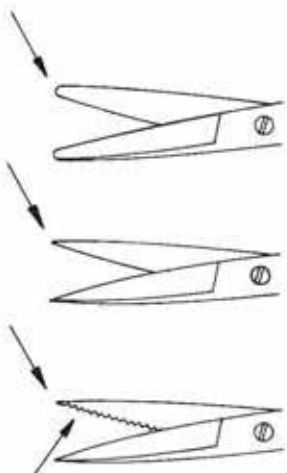

**Dissection:** **Curved blades, slightly rounded tips** ensure safe dissection without damage to nerves and vessels.

**Adventitia:** **Straight blades, very sharp tips** for finest trimming of vessel ends.

**Nerve:** One blade is **fine-toothed** to avoid slipping of the nerve.



SCHEREN SCISSORS TIJERAS CISEAUX FORBICI

Mikroscheren  
Micro Scissors  
Micro Tijeras  
Micro Ciseaux  
Micro Forbici

AA

AB

AC

AD

AE

AF

AK

AL

AO

KA

KK

X



14,5 cm/5<sup>3</sup>/<sub>4</sub>"



**Dissection**  
AC 801/15



**Adventitia**  
AC 803/15



18,0 cm/7"



**Dissection**  
AC 801/18



**Adventitia**  
AC 803/18

Mikroscheren  
Micro Scissors  
Micro Tijeras  
Micro Ciseaux  
Micro Forbici

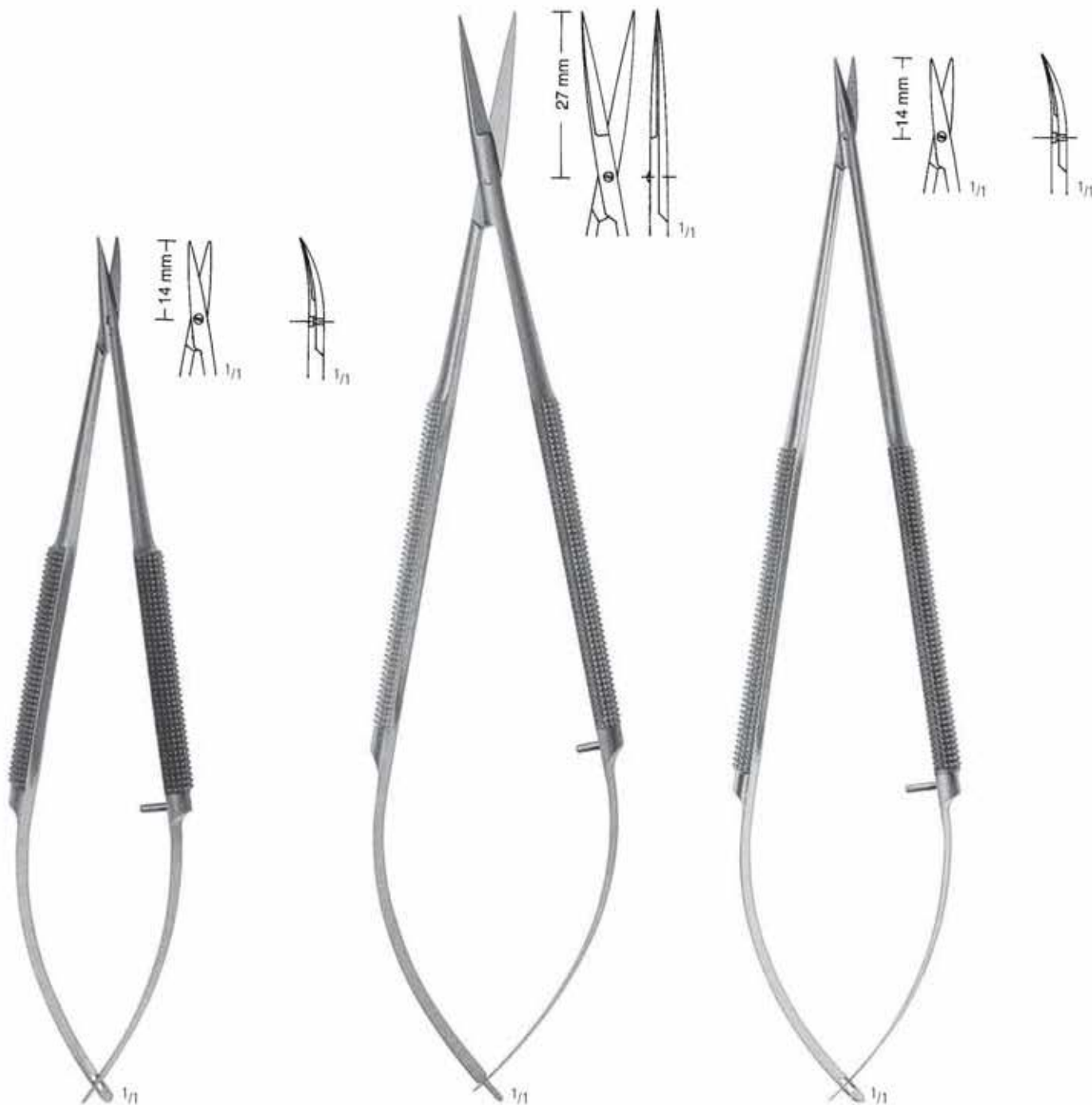

AC 807/14  
14,5 cm/5<sup>3</sup>/<sub>4</sub>"

AC 812/18  
18,0 cm/7"

AC 817/18  
18,0 cm/7"

SCHEREN SCISSORS TIJERAS CISEAUX FORBICI

Mikroscheren  
Micro Scissors  
Micro Tijeras  
Micro Ciseaux  
Micro Forbici

AA

AB

AC

AD

AE

AF

AK

AL

AO

KA

KK

X



11,0 cm/4<sup>1</sup>/<sub>3</sub>"

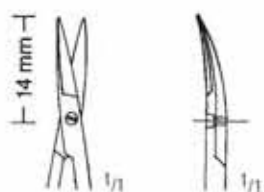

Dissection  
AC 821/11

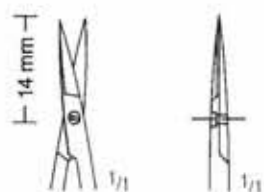

Adventitia  
AC 830/11



15,0 cm/6"

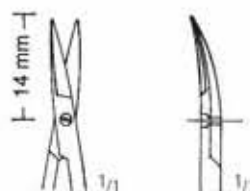

Dissection  
AC 823/15

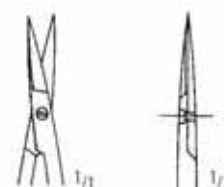

Adventitia  
AC 832/15

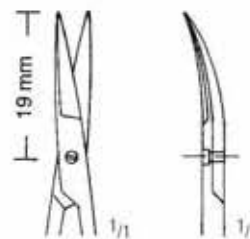

Dissection  
AC 825/15

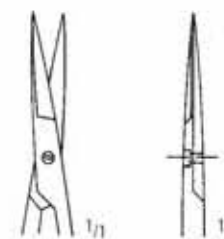

Adventitia  
AC 834/15

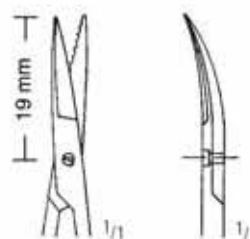

Dissection

>> Nerve >>

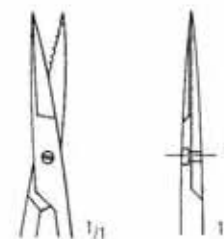

Adventitia  
AC 836/15

AC SCHEREN SCISSORS TIJERAS CISEAUX FORBICI

Mikroscheren  
Micro Scissors  
Micro Tijeras  
Micro Ciseaux  
Micro Forbici



18,5 cm/7<sup>1</sup>/<sub>3</sub>"



AC 850/19



AC 851/19



16,0 cm/6<sup>1</sup>/<sub>4</sub>"  
20,0 cm/8"  
22,5 cm/9"

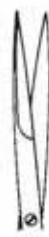

AC 860/16  
AC 860/20  
AC 860/22



AC 861/16  
AC 861/20  
AC 861/22



AC 862/16  
AC 862/20  
AC 862/22



AC 863/16  
AC 863/20  
AC 863/22



AC 864/16  
AC 864/20  
AC 864/22



AC 865/16  
AC 865/20  
AC 865/22

SCHEREN SCISSORS TIJERAS CISEAUX FORBICI

Mikroscheren  
Micro Scissors  
Micro Tijeras  
Micro Ciseaux  
Micro Forbici



18,0 cm/7"



AC 870/01  
25°



AC 870/02  
45°



AC 870/03  
60°



AC 870/04  
90°



AC 870/05  
125°



18,0 cm/7"



AC 871/01  
25°



AC 871/02  
45°



AC 871/03  
60°



AC 871/04  
90°



AC 871/05  
125°

AA  
AB  
AC  
AD  
AE  
AF  
AK  
AL  
AO  
KA  
KK  
X



Mikroscheren  
Micro Scissors  
Micro Tijeras  
Micro Ciseaux  
Micro Forbici



18,0 cm/7"



AC 870/11 T  
25°



AC 870/12 T  
45°



AC 870/13 T  
60°



AC 870/14 T  
90°



AC 870/15 T  
125°

## TITANIUM



18,0 cm/7"



AC 871/11 T  
25°



AC 871/12 T  
45°



AC 871/13 T  
60°



AC 871/14 T  
90°



AC 871/15 T  
125°

# nopa<sup>®</sup> TUC<sup>®</sup>

## SC Super Cut

### SUPER-CUT TUC



#### Besonderheit:

Nutzen Sie die Vorteile von Hartmetalleinsätzen.

**nopa TUC Super Cut** Scheren haben eine rasierklingscharfe Schneide, kombiniert mit einer mikrogezahnten Schneide.

>> Diese Scheren sind durch schwarz/goldene Ringe gekennzeichnet.

#### Features:

Use the advantages of Tungsten Carbide.

**nopa TUC Super Cut** scissors have a razor-like edge combined with one micro serrated blade.

>> Black/golden rings for easy identification.

#### Verfügbare Modelle / Available Patterns

Im Katalog durch \* markiert. / Marked in catalog with \*.

AC 902/14	SC	STANDARD SCS TUC STR.	SH/BL	14,5 CM	SC
AC 903/14	SC	STANDARD SCS TUC CVD.	SH/BL	14,5 CM	SC
AC 910/14	SC	MAYO DISS. SCS TUC STR.	BL/BL	14,5 CM	SC
AC 910/17	SC	MAYO DISS. SCS TUC STR.	BL/BL	17,0 CM	SC
AC 911/14	SC	MAYO DISS. SCS TUC CVD.	BL/BL	14,5 CM	SC
AC 911/17	SC	MAYO DISS. SCS TUC CVD.	BL/BL	17,0 CM	SC
AC 930/14	SC	METZENBAUM SCS TUC STR.	BL/BL	14,5 CM	SC
AC 931/14	SC	METZENBAUM SCS TUC CVD.	BL/BL	14,5 CM	SC
AC 940/18	SC	METZENBAUM SCS TUC STR.	BL/BL	18,0 CM	SC
AC 940/20	SC	METZENBAUM SCS TUC STR.	BL/BL	20,0 CM	SC
AC 941/18	SC	METZENBAUM SCS TUC CVD.	BL/BL	18,0 CM	SC
AC 941/20	SC	METZENBAUM SCS TUC CVD.	BL/BL	20,0 CM	SC
AC 941/23	SC	METZENBAUM SCS TUC CVD.	BL/BL	23,0 CM	SC
AC 941/25	SC	METZENBAUM SCS TUC CVD.	BL/BL	25,0 CM	SC
AC 941/28	SC	METZENBAUM SCS TUC CVD.	BL/BL	28,0 CM	SC
AC 960/14	SC	METZENBAUM-DEL. SCS TUC STR.	BU/BL	14,5 CM	SC
AC 961/14	SC	METZENBAUM-DEL. SCS TUC CVD.	BL/BL	14,5 CM	SC
AC 970/18	SC	METZENBAUM-DEL. SCS TUC STR.	BL/BL	18,0 CM	SC
AC 970/20	SC	METZENBAUM-DEL. SCS TUC STR.	BL/BL	20,0 CM	SC
AC 971/18	SC	METZENBAUM-DEL. SCS TUC CVD.	BL/BL	18,0 CM	SC
AC 971/20	SC	METZENBAUM-DEL. SCS TUC CVD.	BL/BL	20,0 CM	SC
AC 974/11	SC	STEVENS TENOTOMY SCS STR.	POINTED	11,5 CM	SC
AC 975/11	SC	STEVENS TENOTOMY SCS CVD.	POINTED	11,5 CM	SC
AC 984/11	SC	IRIS SCS TUC STR.	SH/SH	11,5 CM	SC
AC 985/11	SC	IRIS SCS TUC CVD.	SH/SH	11,5 CM	SC

**AC** SCHEREN SCISSORS TIJERAS CISEAUX FORBICI

Scheren mit Hartmetalleinlagen  
 Scissors with Tungsten Carbide Inserts  
 Tijeras con filos de carburo de tungsteno  
 Ciseaux avec plaquettes en carbure de tungstène  
 Forbici con taglio al carburo di tungsteno

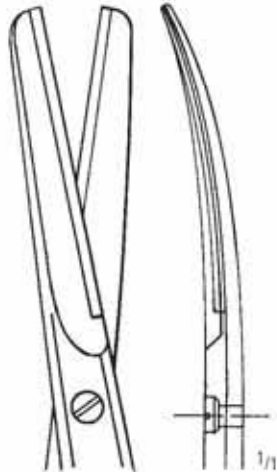

**STANDARD**  
 Fig. 1

straight: 14,5 cm/5<sup>3</sup>/<sub>4</sub>"  
 AC 900/14  
 curved: AC 901/14

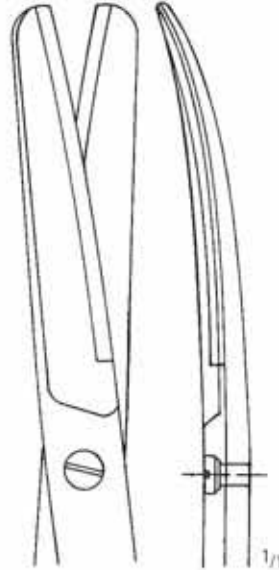

16,5 cm/6<sup>1</sup>/<sub>2</sub>"  
 AC 900/16  
 AC 901/16

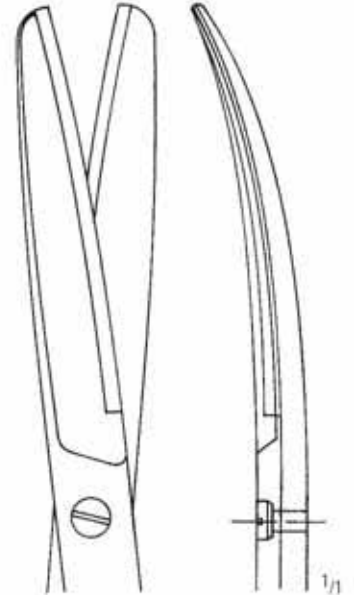

18,5 cm/7<sup>1</sup>/<sub>3</sub>"  
 AC 900/18  
 AC 901/18

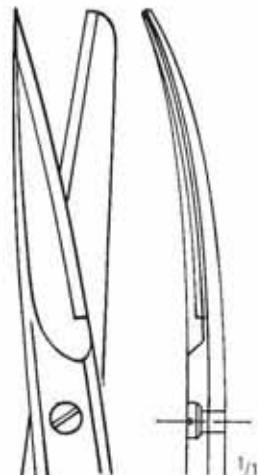

**STANDARD**  
 Fig. 2

straight: 14,5 cm/5<sup>3</sup>/<sub>4</sub>"  
 AC 902/14\*  
 curved: AC 903/14\*

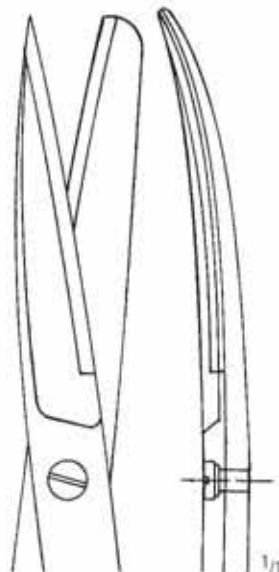

16,5 cm/6<sup>1</sup>/<sub>2</sub>"  
 AC 902/16  
 AC 903/16

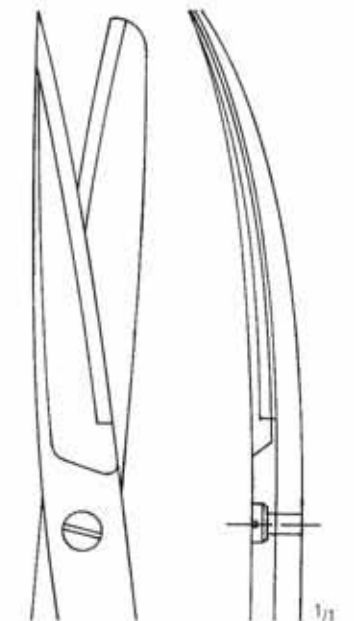

18,5 cm/7<sup>1</sup>/<sub>3</sub>"  
 AC 902/18  
 AC 903/18



SCHEREN SCISSORS TIJERAS CISEAUX FORBICI

Scheren mit Hartmetalleinlagen  
 Scissors with Tungsten Carbide Inserts  
 Tijeras con filos de carburo de tungsteno  
 Ciseaux avec plaquettes en carbure de tungstène  
 Forbici con taglio al carburo di tungsteno

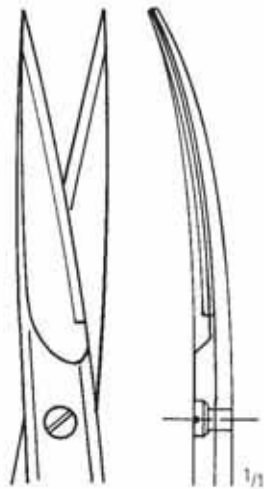

**STANDARD**  
 Fig. 3

straight: 14,5 cm/5<sup>3</sup>/<sub>4</sub>"  
 AC 904/14  
 curved: AC 905/14

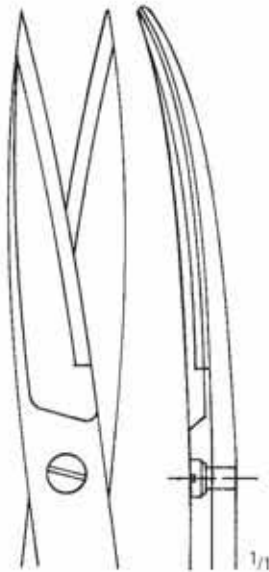

16,5 cm/6<sup>1</sup>/<sub>2</sub>"  
 AC 904/16  
 AC 905/16

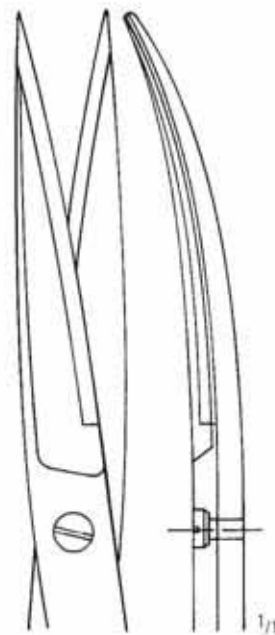

18,5 cm/7<sup>1</sup>/<sub>3</sub>"  
 AC 904/18  
 AC 905/18

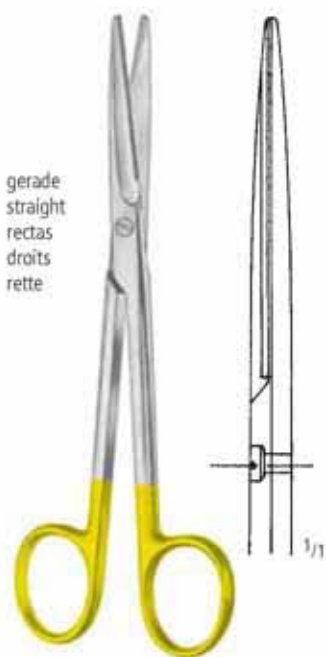

gerade  
 straight  
 rectas  
 droits  
 rette

**MAYO**  
 AC 910/14\*  
 AC 910/17\*  
 AC 910/23

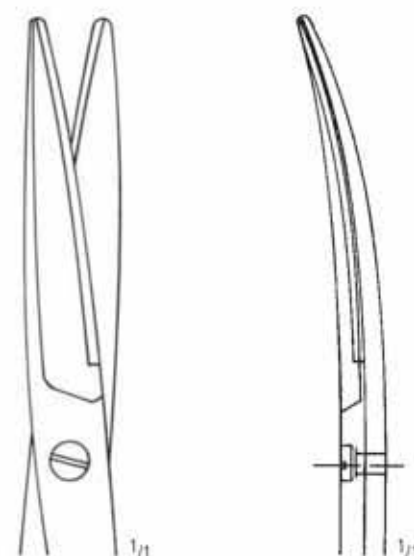

Original 17,0 cm

14,5 cm/5<sup>1</sup>/<sub>2</sub>"  
 17,0 cm/6<sup>3</sup>/<sub>4</sub>"  
 23,0 cm/9"



gebogen  
 curved  
 curvas  
 courbes  
 curve

**MAYO**  
 AC 911/14\*  
 AC 911/17\*  
 AC 911/23

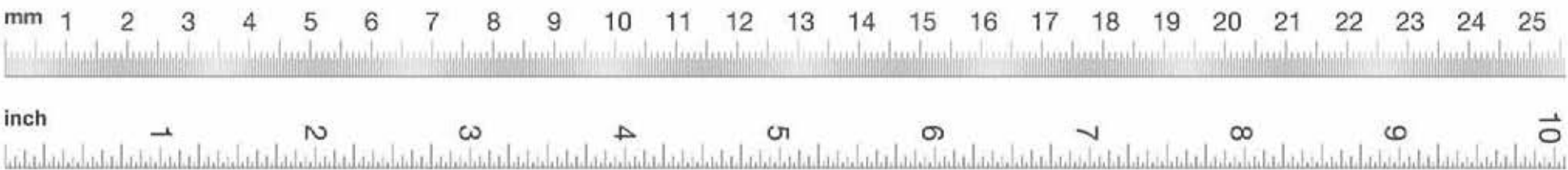



SCHEREN SCISSORS TIJERAS CISEAUX FORBICI

Scheren mit Hartmetalleinlagen  
 Scissors with Tungsten Carbide Inserts  
 Tijeras con filos de carburo de tungsteno  
 Ciseaux avec plaquettes en carbure de tungstène  
 Forbici con taglio al carburo di tungsteno

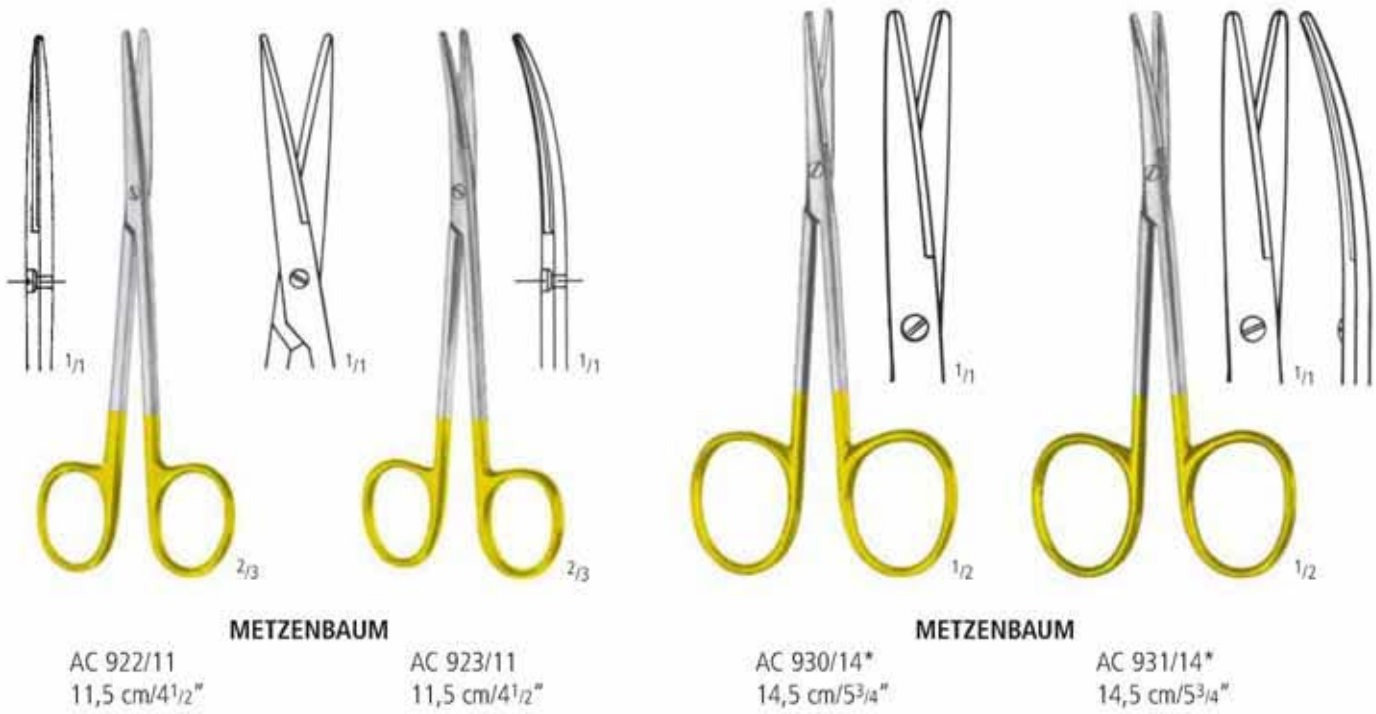

**AC** SCHEREN SCISSORS TIJERAS CISEAUX FORBICI

Scheren mit Hartmetalleinlagen  
 Scissors with Tungsten Carbide Inserts  
 Tijeras con filos de carburo de tungsteno  
 Ciseaux avec plaquettes en carbure de tungstène  
 Forbici con taglio al carburo di tungsteno

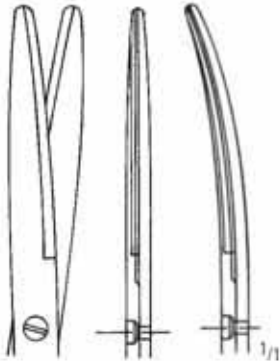

Original 18,0 cm

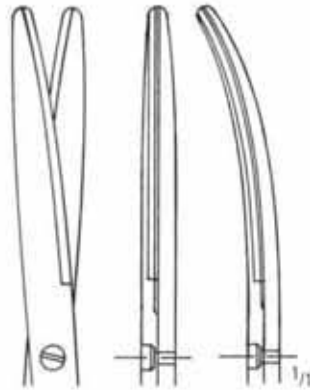

Original 20,0 cm

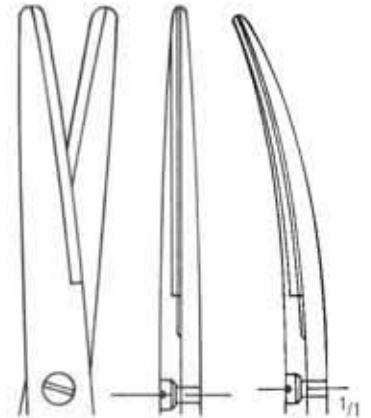

Original 23,0 cm



**nopa**  
**TUC<sup>®</sup>**

gerade  
 straight  
 rectas  
 droits  
 rette

gebogen  
 curved  
 curvas  
 courbes  
 curve

AC 940/18*	18,0 cm/7"	AC 941/18*
AC 940/20*	20,0 cm/8"	AC 941/20*
AC 940/23	23,0 cm/9"	AC 941/23*
AC 940/25	25,0 cm/10"	AC 941/25*
AC 940/28	28,0 cm/11"	AC 941/28*
AC 940/30	30,0 cm/12"	AC 941/30

**METZENBAUM**

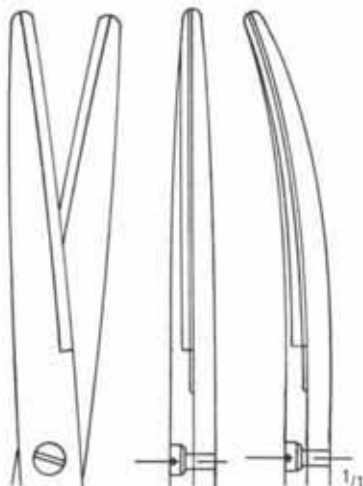

Original 25,0 cm

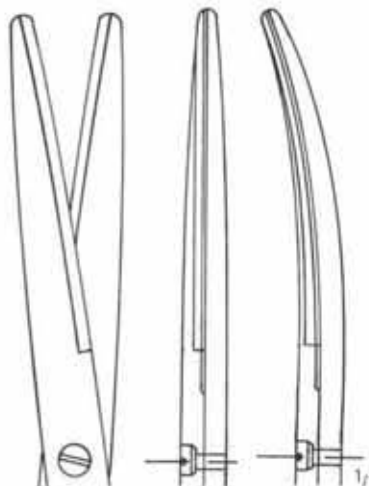

Original 28,0 cm

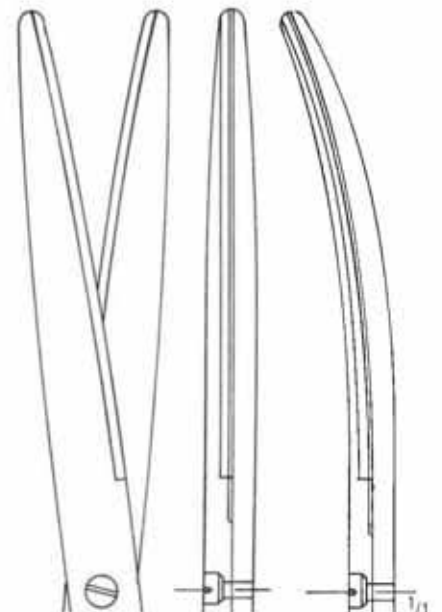

Original 30,0 cm

SCHEREN SCISSORS TIJERAS CISEAUX FORBICI

Scheren mit Hartmetalleinlagen  
 Scissors with Tungsten Carbide Inserts  
 Tijeras con filos de carburo de tungsteno  
 Ciseaux avec plaquettes en carbure de tungstène  
 Forbici con taglio al carburo di tungsteno



**POTT-SMITH**  
 19,0 cm/7 1/2"

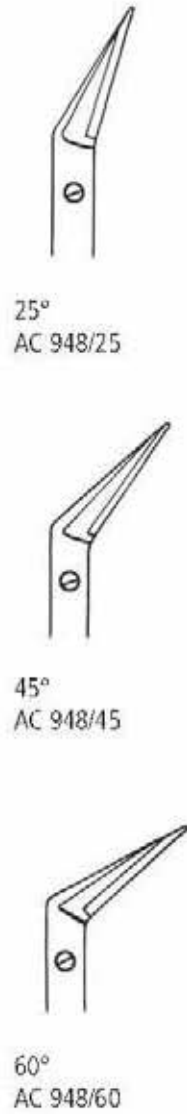

**DE BAKHEY**  
 18,0 cm/7"

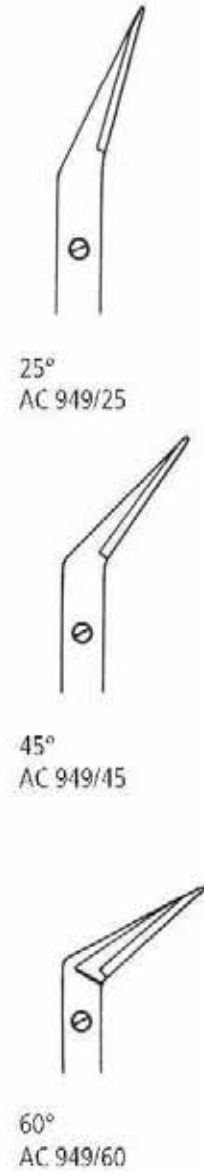

AA  
 AB  
 AC  
 AD  
 AE  
 AF  
 AK  
 AL  
 AO  
 KA  
 KK  
 X

**AC** SCHEREN SCISSORS TIJERAS CISEAUX FORBICI

Scheren mit Hartmetalleinlagen  
 Scissors with Tungsten Carbide Inserts  
 Tijeras con filos de carburo de tungsteno  
 Ciseaux avec plaquettes en carbure de tungstène  
 Forbici con taglio al carburo di tungsteno



**LEXER**  
 AC 952/16  
 16,0 cm/6<sup>1</sup>/<sub>4</sub>"

**LEXER**  
 AC 953/16  
 16,0 cm/6<sup>1</sup>/<sub>4</sub>"

nopa  
**TUC<sup>®</sup>**

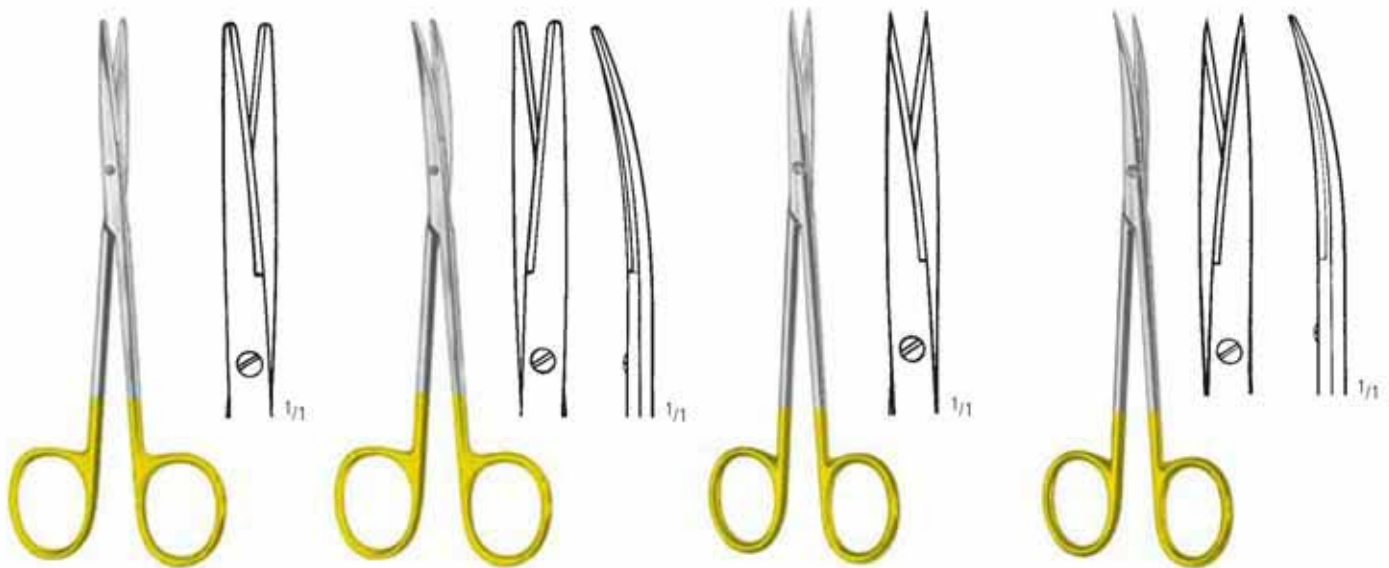

AC 960/14\*  
 14,5 cm/5<sup>3</sup>/<sub>4</sub>"

AC 961/14\*  
 14,5 cm/5<sup>3</sup>/<sub>4</sub>"

**METZENBAUM-DELICATE**

AC 962/14  
 14,5 cm/5<sup>3</sup>/<sub>4</sub>"

AC 963/14  
 14,5 cm/5<sup>3</sup>/<sub>4</sub>"

SCHEREN SCISSORS TIJERAS CISEAUX FORBICI

Scheren mit Hartmetalleinlagen  
 Scissors with Tungsten Carbide Inserts  
 Tijeras con filos de carburo de tungsteno  
 Ciseaux avec plaquettes en carbure de tungstène  
 Forbici con taglio al carburo di tungsteno

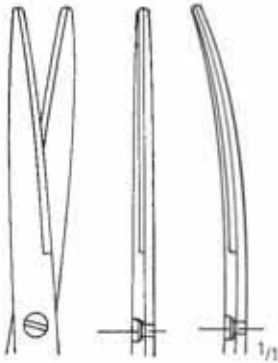

Original 18,0 cm

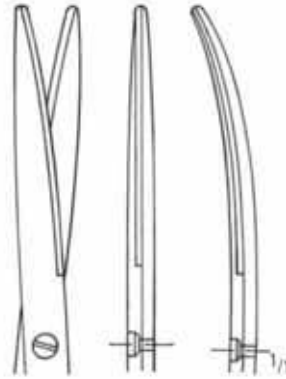

Original 20,0 cm

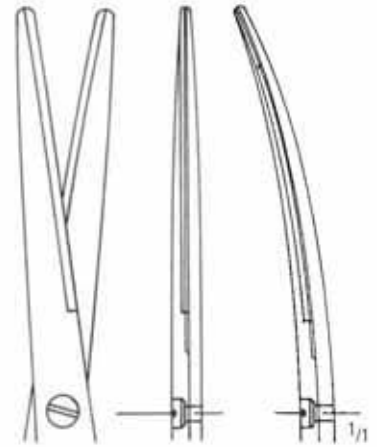

Original 23,0 cm



METZENBAUM-DELICATE



gerade  
 straight  
 rectas  
 droits  
 rette

gebogen  
 curved  
 curvas  
 courbes  
 curve

AC 970/18*	18,0 cm/7"	AC 971/18*
AC 970/20*	20,0 cm/8"	AC 971/20*
AC 970/23	23,0 cm/9"	AC 971/23
AC 970/25	25,0 cm/10"	AC 971/25
AC 970/28	28,0 cm/11"	AC 971/28

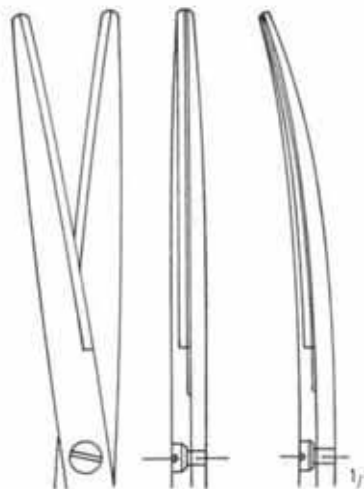

Original 25,0 cm

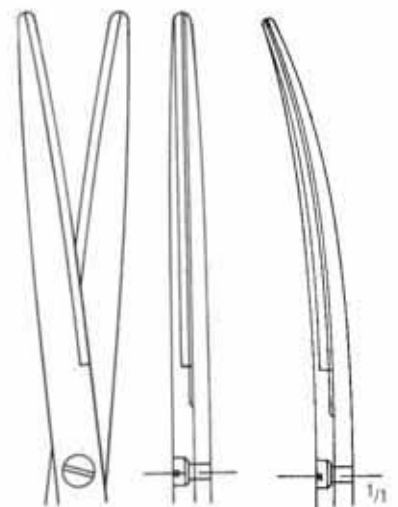

Original 28,0 cm

AA  
 AB  
 AC  
 AD  
 AE  
 AF  
 AG  
 AH  
 AI  
 AJ  
 AK  
 AL  
 AM  
 AN  
 AO  
 AP  
 AQ  
 AR  
 AS  
 AT  
 AU  
 AV  
 AW  
 AX



**AC** SCHEREN SCISSORS TIJERAS CISEAUX FORBICI

Scheren mit Hartmetalleinlagen  
 Scissors with Tungsten Carbide Inserts  
 Tijeras con filos de carburo de tungsteno  
 Ciseaux avec plaquettes en carbure de tungstène  
 Forbici con taglio al carburo di tungsteno

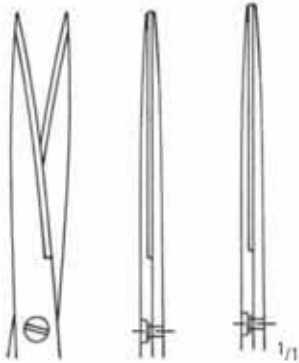

Original 18,0 cm

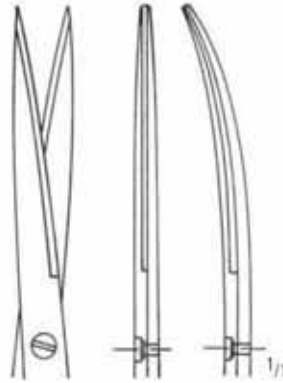

Original 20,0 cm

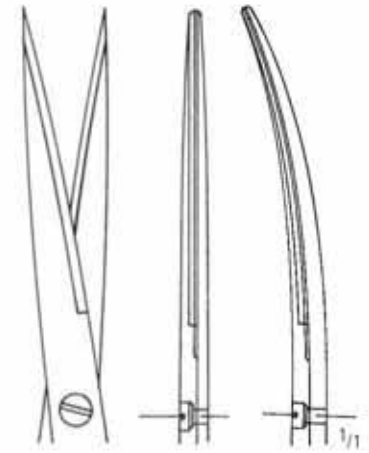

Original 23,0 cm



**METZENBAUM-DELICATE**

**nopa  
TUC<sup>®</sup>**

gerade  
straight  
rectas  
droits  
rette

gebogen  
curved  
curvas  
courbes  
curve

AC 972/18	18,0 cm/7"	AC 973/18
AC 972/20	20,0 cm/8"	AC 973/20
AC 972/23	23,0 cm/9"	AC 973/23
AC 972/25	25,0 cm/10"	AC 973/25
AC 972/28	28,0 cm/11"	AC 973/28

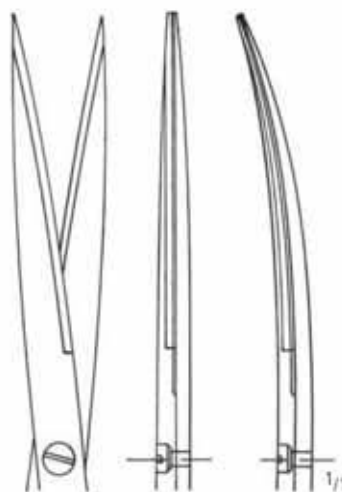

Original 25,0 cm

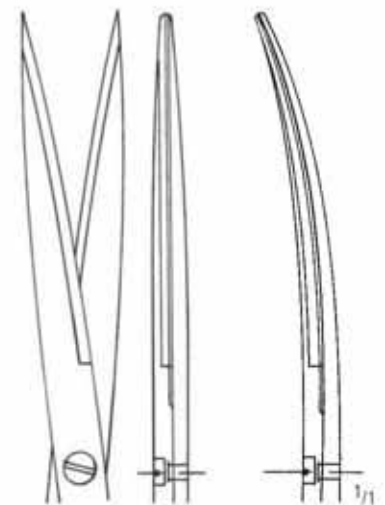

Original 28,0 cm

SCHEREN SCISSORS TIJERAS CISEAUX FORBICI

Scheren mit Hartmetalleinlagen  
 Scissors with Tungsten Carbide Inserts  
 Tijeras con filos de carburo de tungsteno  
 Ciseaux avec plaquettes en carbure de tungstène  
 Forbici con taglio al carburo di tungsteno



Original 11,5 cm

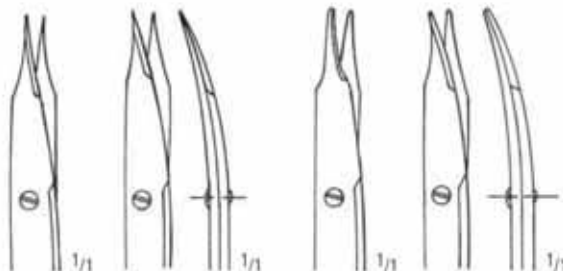

spitz  
pointed  
agudas  
pointues  
acuta

stumpf  
blunt  
romas  
mousses  
smussa

gerade  
straight  
rectas  
droits  
rette

gebogen  
curved  
curvas  
courbes  
curve

gerade  
straight  
rectas  
droits  
rette

gebogen  
curved  
curvas  
courbes  
curve

**STEVENS**

10,5 cm/4<sup>1</sup>/<sub>4</sub>"  
 11,5 cm/4<sup>1</sup>/<sub>2</sub>"

AC 974/10  
 AC 974/11\*

AC 975/10  
 AC 975/11\*

AC 976/10  
 AC 976/11

AC 977/10  
 AC 977/11

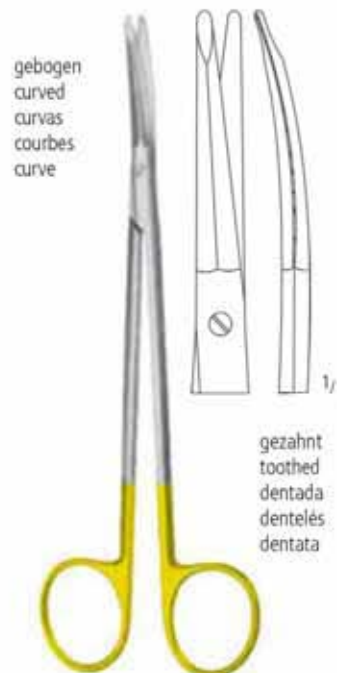
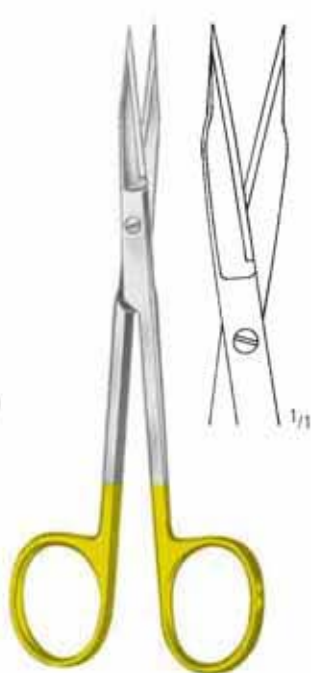
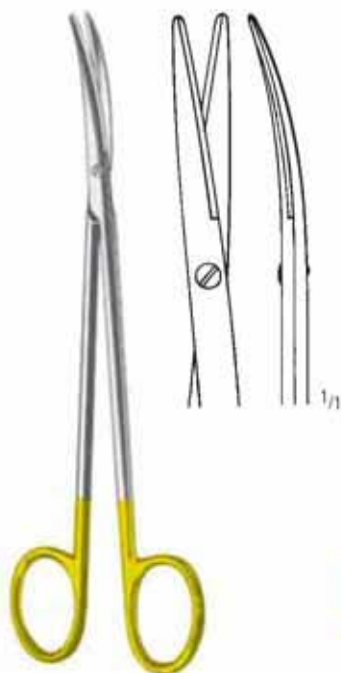

gebogen  
curved  
curvas  
courbes  
curve

gezahnt  
toothed  
dentada  
denteles  
dentata

**TOENNIS-ADSON-DELICATE**

AC 977/17  
 17,5 cm/7"

**GOLDMAN-FOX**

AC 980/13  
 13,0 cm/5"

AC 981/13  
 13,0 cm/5"

**KAYE**

AC 983/15  
 15,0 cm/6"

\* Auch erhältlich als SC \* Also available as SC

AA  
 AB  
 AC  
 AD  
 AE  
 AF  
 AK  
 AL  
 AO  
 KA  
 KK  
 X

AC SCHEREN SCISSORS TIJERAS CISEAUX FORBICI

Scheren mit Hartmetalleinlagen  
 Scissors with Tungsten Carbide Inserts  
 Tijeras con filos de carburo de tungsteno  
 Ciseaux avec plaquettes en carbure de tungstène  
 Forbici con taglio al carburo di tungsteno



AC 984/11\*  
 11,5 cm/4<sup>1</sup>/<sub>2</sub>"



AC 985/11\*  
 11,5 cm/4<sup>1</sup>/<sub>2</sub>"

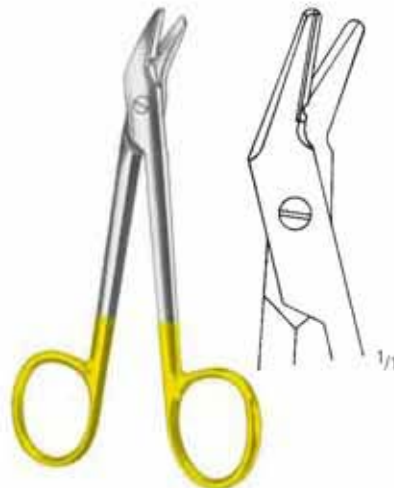

**UNIVERSAL**  
 AC 987/12  
 12,0 cm/4<sup>3</sup>/<sub>4</sub>"



**LISTER**  
 AC 999/18  
 18,0 cm/7"

SKALPELLE  
SCALPELS  
BISTURIES  
BISTOURIS  
BISTURI

AD

nopa<sup>®</sup> instruments

Weitere Skalpelle finden Sie in unserem Katalog "Allgemeine Chirurgie" in Gruppe AD.

For further scalpels kindly refer to our catalogue "General Surgery", section AD.

Para bisturías adicionales, por favor consulte nuestro catálogo de "Cirugía general", grupo AD.

Pour des bistouris supplémentaires, consultez notre catalogue "Chirurgie Generale", section AD.

Per gli altri bisturi, consultare il nostro catalogo "Chirurgia Generale", gruppo AD.





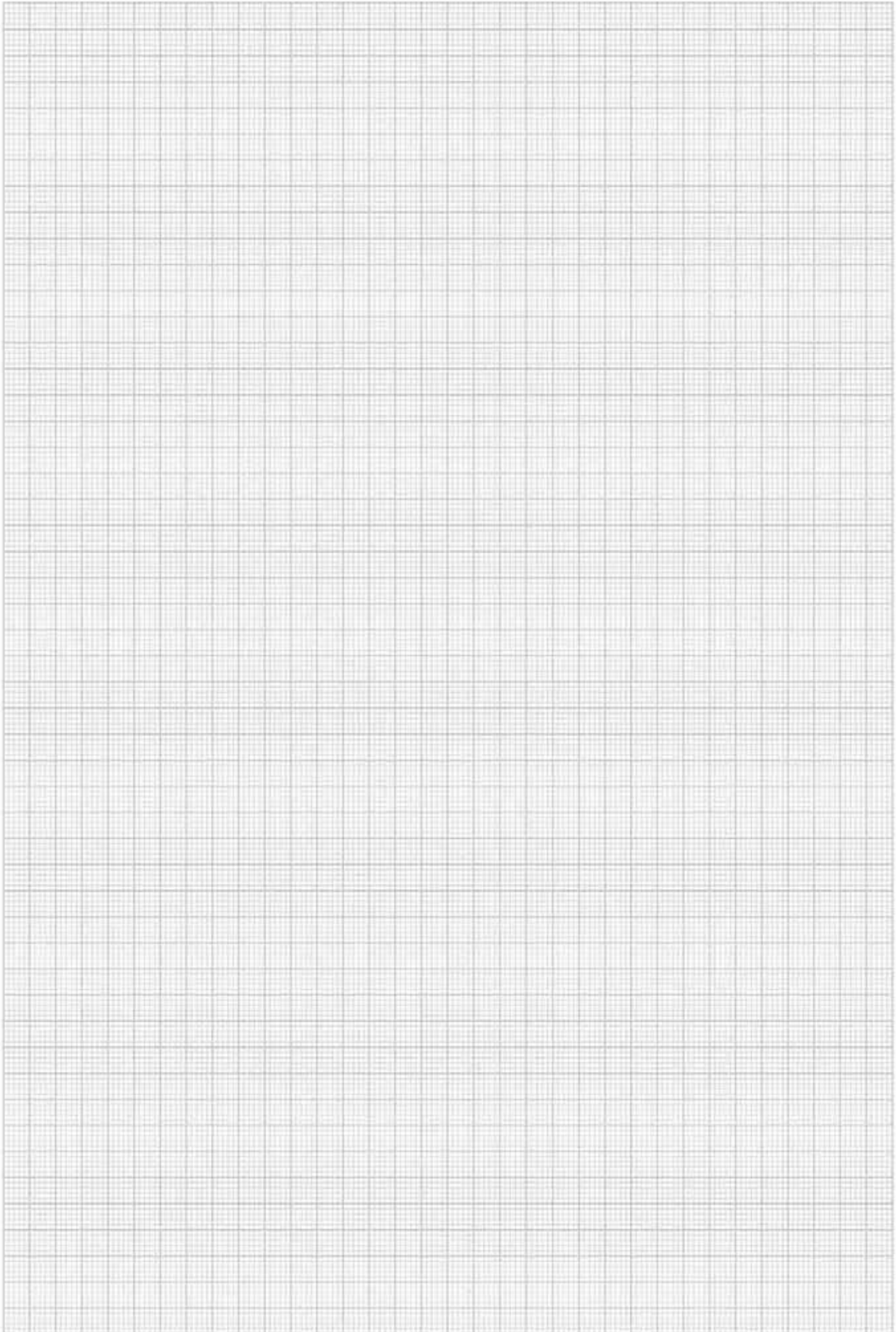



SKALPELLE SCALPELS BISTURIES BISTOURIS BISTURI

Skalpgriffe  
 Scalpel Handles  
 Mangos de bisturíes  
 Manches pour bistouris  
 Manici per bisturi



AD 009/03  
 No. 3

AD 010/03  
 No. 3

AD 010/04  
 No. 4

AD 010/05  
 No. 5K

AD 020/13  
 No. 3L

AD 020/14  
 No. 4L

AD 020/15  
 No. 5L

AA  
 AB  
 AC  
**AD**  
 AE  
 AF  
 AK  
 AL  
 AO  
 KA  
 KK  
 X

Skalpelli griffe  
 Scalpel Handles  
 Mangos de bisturles  
 Manches pour bistouris  
 Manici per bisturi



AD 025/07  
 No. 7



AD 027/07  
 No. 7K



AD 030/16



AD 031/21



**COLLIN**  
 AD 040/08  
 No. 8

hohl  
 hollow  
 hueco  
 creux  
 vuoto



**COLLIN**  
 AD 042/09  
 No. 9

Skalpelli-griffe, Skalpelli-klingen  
 Scalpel Handles, Scalpel Blades  
 Mangos de bisturías, Hojas de bisturías  
 Manches pour bistouris, Lames de bistouris  
 Manici per bisturi, Lame per bisturi

# MINI

Verpackungseinheit / packing unit = 10 St./pc.

AA

AB

AC

AD

AE

AF

AK

AL

AO

KA

KK

X



Fig. 61  
AD 065/61



Fig. 62  
AD 065/62



Fig. 62S  
AD 065/63



Fig. 64  
AD 065/64



Fig. 65  
AD 065/65



Fig. 67  
AD 065/67



Fig. 69  
AD 065/69

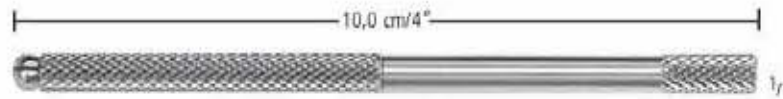

AD 065/10



AD 065/13



AD 065/15

**AD** SKALPELLE SCALPELS BISTURIES BISTOURIS BISTURI

Skalpellsklingen  
 Scalpel Blades  
 Hojas de bisturíes  
 Lames pour bistouris  
 Lame per bisturi

passend für die Griffe  
 for handles  
 para los mangos  
 pour les manches  
 per i manici

- AD 009/03
- AD 010/03
- AD 020/13
- AD 025/07
- AD 027/07
- AD 030/16
- AD 040/08



Fig.10  
AD 075/10



Fig.11  
AD 075/11



Fig.12d  
AD 076/12



Fig.15  
AD 075/15



Fig.15c  
AD 076/15



steril  
 sterile  
 estériles  
 stériles  
 sterili

passend für die Griffe  
 for handles  
 para los mangos  
 pour les manches  
 per i manici

- AD 010/04
- AD 020/14
- AD 042/09



Fig.20  
AD 075/20



Fig.21  
AD 075/21



Fig.22  
AD 075/22



Fig.23  
AD 075/23



Fig.24  
AD 075/24

NAHT  
SUTURE  
SUTURA  
SUTURE  
SUTURA

AE

nopa<sup>®</sup> instruments

Weitere Naht-Instrumente finden Sie in unserem Katalog "Allgemeine Chirurgie" in Gruppe AE.

For further suture instruments kindly refer to our catalogue "General Surgery", section AE.

Para instrumentos de sutura adicionales, por favor consulte nuestro catálogo de "Cirugía general", grupo AE.

Pour des instruments de suture supplémentaires, consultez notre catalogue "Chirurgie Generale", section AE.

Per gli altri accessori di sutura, consultare il nostro catalogo "Chirurgia Generale", gruppo AE.





**AE** NAHT SUTURE SUTURA SUTURE SUTURA

Hartmetalleinsatzplättchen mit Pyramidenprofil  
 Tungsten Carbide Tips with pyramidal profile  
 Bocas de carburo de tungsteno con perfil de estructura piramidal  
 Plaquettes en carbure de tungstène avec profil pyramidal  
 Placche di carburo di tungsteno con profilo in forma piramidale

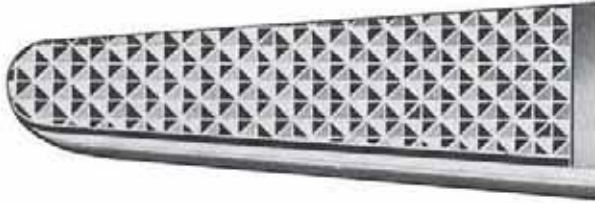

**"STANDARD"**

(Mayo-Hegar, Mathieu, Bozeman, New Orleans, Stratte, etc.)

Teilung:	0,5 mm	Für Nahtmaterial 3/0 und größer
Serration:	0,5 mm	For suture sizes 3/0 and larger
Graduación:	0,5 mm	Para sutura 3/0 y más grande
Graduation:	0,5 mm	Pour suture 3/0 et plus grand
Graduazione:	0,5 mm	Per sutura 3/0 e più grande

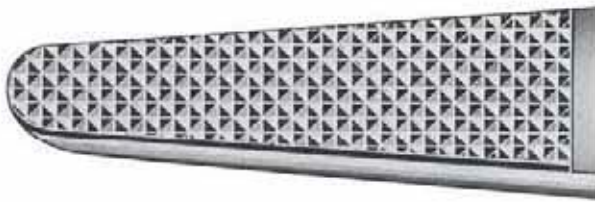

**"FINE"**

(Crile-Wood, Halsey, DeBakey, Ryder, etc.)

Teilung:	0,4 mm	Für Nahtmaterial zwischen 3/0 und 6/0
Serration:	0,4 mm	For suture sizes between 3/0 and 6/0
Graduación:	0,4 mm	Para suturas entre 3/0 y 6/0
Graduation:	0,4 mm	Pour sutures entre 3/0 et 6/0
Graduazione:	0,4 mm	Per sutura tra 3/0 e 6/0



**"MICRO"**

(Micro Ryder, Microvascular, Castroviejo, etc.)

Teilung:	0,2 mm	Für Nahtmaterial zwischen 7/0 und 10/0
Serration:	0,2 mm	For suture sizes between 7/0 and 10/0
Graduación:	0,2 mm	Para suturas entre 7/0 y 10/0
Graduation:	0,2 mm	Pour sutures entre 7/0 et 10/0
Graduazione:	0,2 mm	Per sutura tra 7/0 e 10/0



**"SMOOTH"**

(Eufrate Pasqué, Castroviejo, Jacobson, etc.)

glatt	Für extrem feines Nahtmaterial
smooth	For the smallest suture sizes available
lisa	Para suturas extremamente finas
lisses	Pour matériel de suture extrêmement fin
liscio	Per materiale di sutura finissima

NAHT SUTURE SUTURA SUTURE SUTURA

nopa-Service, Ersatzteile und Aufarbeitung aller Fabrikate  
 nopa-Service, Spare Inserts and Refurbishing of all brands  
 Servicio-nopa, piezas de recambio y renovar de todas las marcas  
 Service-nopa, pièces de rechange et remise à neuf de toutes les marques  
 Servizio-nopa, pezzi di ricambio e riparazione di tutte le marche

AA  
 AB  
 AC  
 AD  
**AE**  
 AF  
 AK  
 AL  
 AO  
 KA  
 KK  
 X

**TUC-Einsätze**  
**TUC-Inserts**  
**TUC-Bocas**  
**TUC-Plaquettes**  
**TUC-Placche**

AE 380/15	Smooth, 15 mm
AE 380/17	Smooth, 17 mm
AE 380/19	Smooth, 19 mm
AE 382/15	Micro, 0.2, 15 mm
AE 382/17	Micro, 0.2, 17 mm
AE 382/19	Micro, 0.2, 19 mm
AE 384/15	Fine, 0.4, 15 mm
AE 384/17	Fine, 0.4, 17 mm
AE 384/19	Fine, 0.4, 19 mm
AE 385/15	Standard, 0.5, 15 mm
AE 385/17	Standard, 0.5, 17 mm
AE 385/19	Standard, 0.5, 19 mm

**Reparaturservice**  
**Repair-Service**  
**Servicio de reparación**  
**Service de réparation**  
**Servizio di riparazione**

AE 390/00  
 neue Plättchen einsetzen, aufarbeiten, Ringe vergolden  
 replacement of inserts, refurbishing, gold handles refinished  
 soldar bocas nuevas, repasar, dorar los anillos  
 brasage des nouvelles plaquettes, remise à neuf, redorer les anneaux  
 saldare placche nuove, rinnovare, dorare gli anelli

AE 390/01  
 neue Plättchen einsetzen, aufarbeiten  
 replacement of inserts, refurbishing  
 soldar bocas nuevas, repasar  
 brasage des nouvelles plaquettes, remise à neuf  
 saldare placche nuove, rinnovare

AE 390/03  
 aufarbeiten  
 refurbishing  
 repasar  
 remise à neuf  
 rinnovare

AE 390/02  
 neue Plättchen einsetzen  
 replacement of inserts  
 soldar bocas nuevas  
 brasage des nouvelles plaquettes  
 saldare placche nuove

AE 390/04  
 Ringe vergolden  
 gold handles refinished  
 dorar los anillos  
 redorer les anneaux  
 dorare gli anelli





titan instruments

# nopa<sup>®</sup> instruments

## Besonderheit:

nopa Titan Instrumente bieten insbesondere in der Herz-Thorax-Chirurgie Vorteile gegenüber herkömmlichen Instrumenten. Titan ist ca. 45% leichter als rostfreier Edelstahl, weshalb Titan Instrumente weniger traumatisierend sind. Titan ist außerdem ein vollkommen korrosionsbeständiges und antimagnetisches Material. nopa Titan Instrumente bedeuten größtmöglichen Komfort für den Chirurgen.

## Features:

nopa Titan Instruments provide especially in Cardiovascular surgery a significant advantage compared to other Instruments. Titan is approximately 45% lighter than stainless steel. For that reason, Titan Instruments are less traumatic. Besides that, Titan is a completely stainless and anti-magnetic material. nopa Titan Instruments are the most comfortable choice for the Cardiovascular surgeon.

AE 400/16 T	MAYO-HEGAR NEEDLE HOLDER TUC 16,0 CM
AE 400/18 T	MAYO-HEGAR NEEDLE HOLDER TUC 18,0 CM
AE 400/20 T	MAYO-HEGAR NEEDLE HOLDER TUC 20,0 CM
AE 420/18 T	DE BAKKEY NEEDLE HOLDER TUC 18,0 CM
AE 420/20 T	DE BAKKEY NEEDLE HOLDER TUC 20,0 CM
AE 420/23 T	DE BAKKEY NEEDLE HOLDER TUC 23,0 CM
AE 420/26 T	DE BAKKEY NEEDLE HOLDER TUC 26,0 CM
AE 430/15 T	RYDER/FRENCH-EYE NEEDLE HOLDER TUC 15,0 CM
AE 430/18 T	RYDER/FRENCH-EYE NEEDLE HOLDER TUC 18,0 CM
AE 430/20 T	RYDER/FRENCH-EYE NEEDLE HOLDER TUC 20,0 CM
AE 438/18 T	MICROVASCULAR NEEDLE HOLDER TUC 18,0 CM
AE 438/20 T	MICROVASCULAR NEEDLE HOLDER TUC 20,0 CM
AE 438/23 T	MICROVASCULAR NEEDLE HOLDER TUC 23,0 CM
AE 466/13 T	HALSEY NEEDLE HOLDER TUC 13,0 CM
AE 572/14 T	CASTROVIEJO NH TUC STR RA SERRATED 14,0 CM
AE 580/02 T	JACOBSON MICRO-NH TUC RA SERRATED 21,0CM
AE 632/18 T	MICRO-NEEDLE HOLDER STR 18,0 CM
AE 633/18 T	MICRO-NEEDLE HOLDER CVD 18,0 CM



**AE** NAHT SUTURE SUTURA SUTURE SUTURA

Nadelhalter mit Hartmetalleinsätzen  
 Needle Holders with Tungsten Carbide Inserts  
 Porta-agujas con bocas de carburo de Tungsteno  
 Porte-aiguilles à mors en carbure de tungstène  
 Portaghi con placche di carburo di tungsteno



**MAYO-HEGAR**



AE 400/14  
14,0 cm/5<sup>1</sup>/<sub>2</sub>"



AE 400/16  
16,0 cm/6<sup>1</sup>/<sub>4</sub>"



AE 400/18  
18,0 cm/7"



AE 400/20  
20,0 cm/8"



AE 400/24  
24,0 cm/9<sup>1</sup>/<sub>2</sub>"



AE 400/26  
26,0 cm/10<sup>1</sup>/<sub>2</sub>"



AE 400/30  
30,0 cm/12"

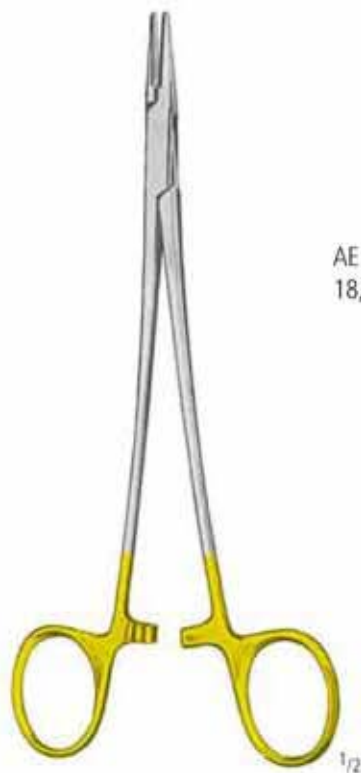

**DE-BAKEY  
 (MAYO-HEGAR-DELICATE)**



AE 420/18  
18,0 cm/7"



AE 420/20  
20,0 cm/8"



AE 420/23  
23,0 cm/9"



AE 420/26  
26,0 cm/10<sup>1</sup>/<sub>2</sub>"



AE 420/31  
31,0 cm/12<sup>1</sup>/<sub>4</sub>"



NAHT SUTURE SUTURA SUTURE SUTURA

Nadelhalter mit Hartmetalleinsätzen  
 Needle Holders with Tungsten Carbide Inserts  
 Porta-agujas con bocas de carburo de Tungsteno  
 Porte-aiguilles à mors en carbure de tungstène  
 Portaghi con placche di carburo di tungsteno

RYDER/FRENCH-EYE

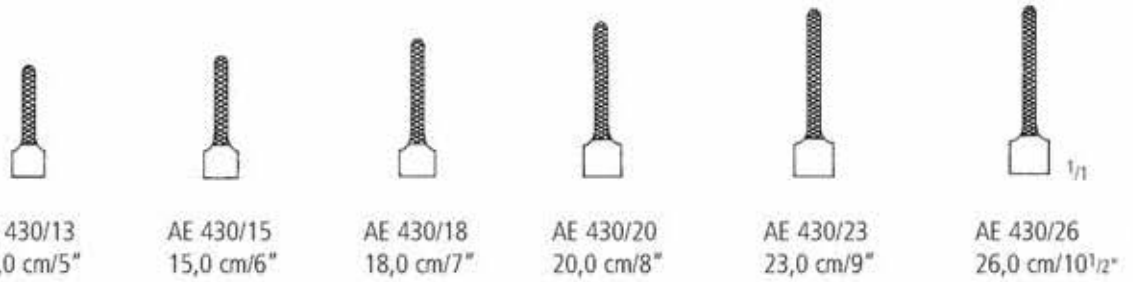

MICRO RYDER

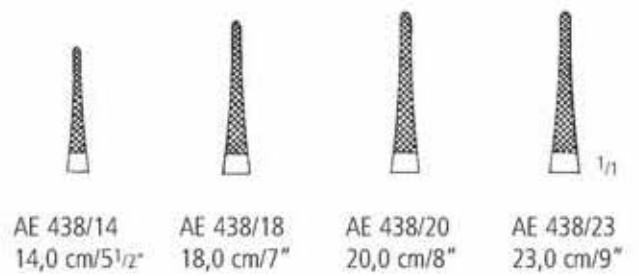
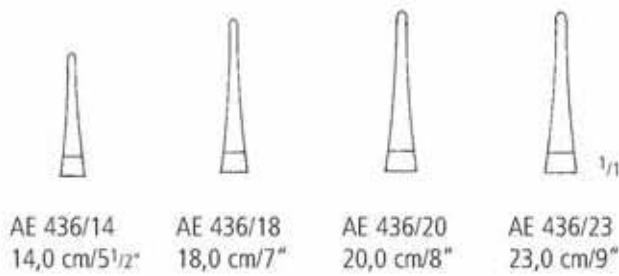
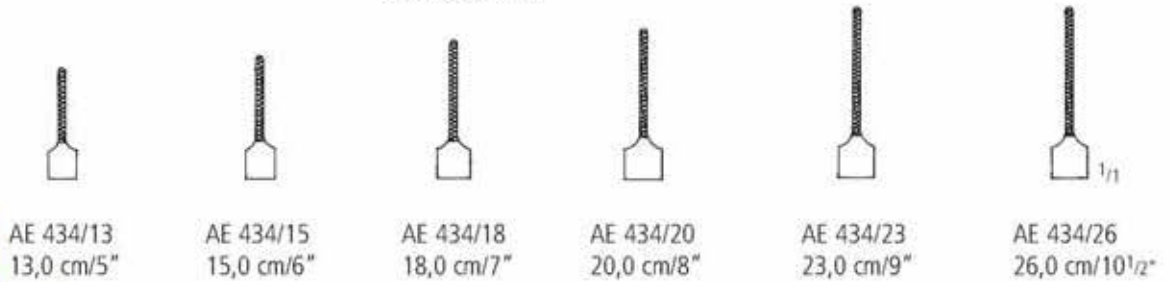

EUFRATE PASQUÉ

extrem fein  
 extremely delicate  
 muy fino  
 très fin  
 molto fino

MICROVASCULAR

AA  
 AB  
 AC  
 AD  
**AE**  
 AF  
 AK  
 AL  
 AO  
 KA  
 KK  
 X

**AE** NAHT SUTURE SUTURA SUTURE SUTURA

Nadelhalter mit Hartmetalleinsätzen  
 Needle Holders with Tungsten Carbide Inserts  
 Porta-agujas con bocas de carburo de Tungsteno  
 Porte-aiguilles à mors en carbure de tungstène  
 Portaghi con placche di carburo di tungsteno



**CARROLL**  
 AE 440/15  
 15,0 cm/6"

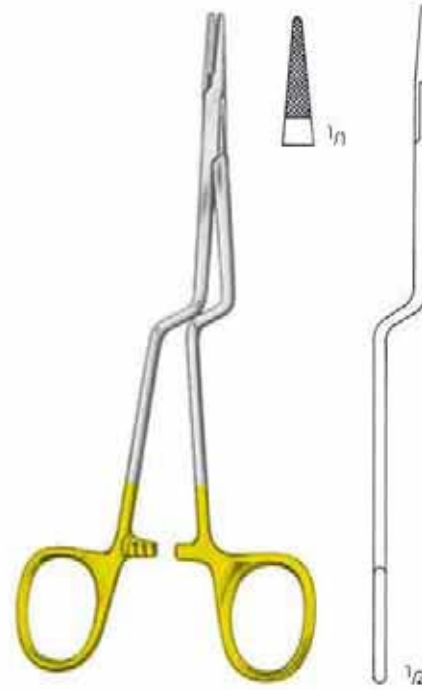

**JACOBSON**  
 AE 444/18  
 18,0 cm/7"



**NEW ORLEANS**  
 AE 446/18  
 18,0 cm/7"



**SENNING**  
 (SWEDISH PATTERN)



AE 448/15  
 15,0 cm/6"



AE 448/17  
 17,0 cm/6<sup>3</sup>/<sub>4</sub>"

NAHT SUTURE SUTURA SUTURE SUTURA

Nadelhalter mit Hartmetalleinsätzen  
 Needle Holders with Tungsten Carbide Inserts  
 Porta-agujas con bocas de carburo de Tungsteno  
 Porte-aiguilles à mors en carbure de tungstène  
 Portaghi con placche di carburo di tungsteno



**DERF**  
 AE 450/12  
 12,5 cm/5"



**CONVERSE**  
 AE 452/12  
 12,5 cm/5"

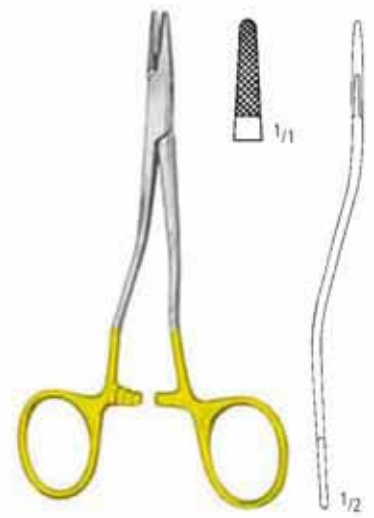

**KILNER**  
 AE 455/13  
 13,5 cm/5 1/4"



**NEIVERT**  
 AE 456/13  
 13,0 cm/5"



**WEBSTER**  
 AE 460/13  
 13,0 cm/5"



**HALSEY**  
 13,0 cm/5"

AA  
 AB  
 AC  
 AD  
**AE**  
 AF  
 AK  
 AL  
 AO  
 KA  
 KK  
 X

**AE** NAHT SUTURE SUTURA SUTURE SUTURA

Nadelhalter mit Hartmetalleinsätzen  
 Needle Holders with Tungsten Carbide Inserts  
 Porta-agujas con bocas de carburo de Tungsteno  
 Porte-aiguilles à mors en carbure de tungstène  
 Portaghi con placche di carburo di tungsteno



**BABY-CRILE-WOOD**  
 AE 468/15  
 15,0 cm/6"



**CRILE-WOOD**  
 AE 469/15  
 15,0 cm/6"



**CRILE-WOOD**  
 AE 470/15  
 15,0 cm/6"

nopa  
**TUC<sup>®</sup>**

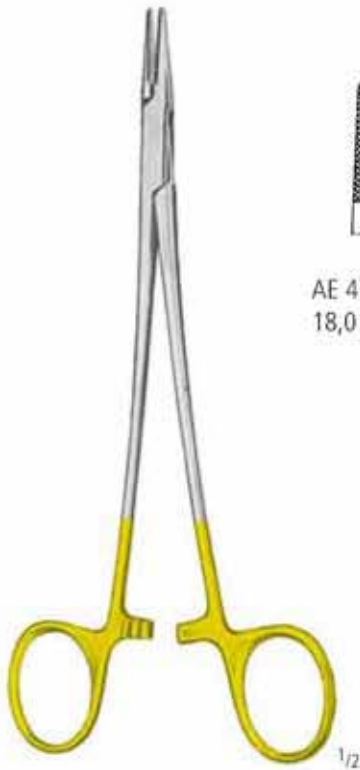

**CRILE-WOOD**



AE 470/18  
 18,0 cm/7"



AE 470/20  
 20,0 cm/8"



AE 470/23  
 23,0 cm/9"



AE 471/18  
 18,0 cm/7"



AE 471/23  
 23,0 cm/9"

NAHT SUTURE SUTURA SUTURE SUTURA

Nadelhalter mit Hartmetalleinsätzen  
 Needle Holders with Tungsten Carbide Inserts  
 Porta-agujas con bocas de carburo de Tungsteno  
 Porte-aiguilles à mors en carbure de tungstène  
 Portaghi con placche di carburo di tungsteno



**FINOCCHIETTO**  
 AE 472/27  
 27,0 cm/10<sup>3</sup>/<sub>4</sub>"

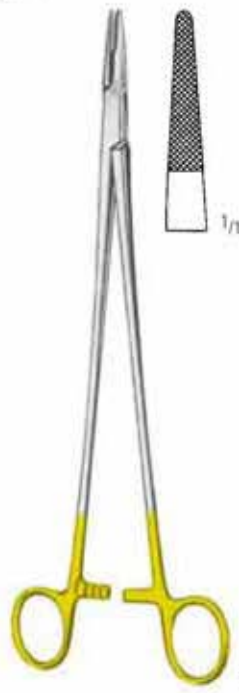

**WANGENSTEEN**  
 AE 474/27  
 27,0 cm/10<sup>3</sup>/<sub>4</sub>"

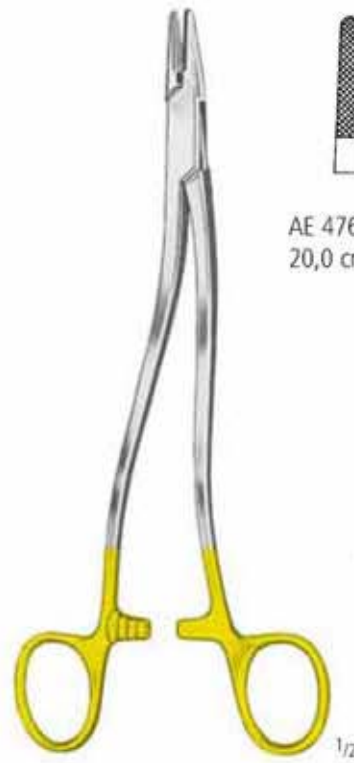

**BOZEMANN**

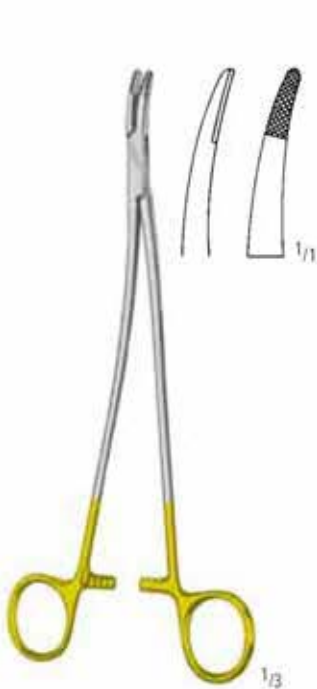
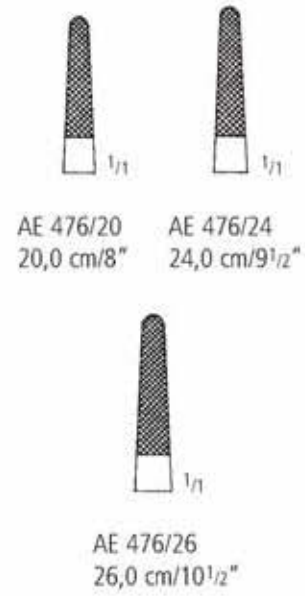

**STRATTE**  
 AE 478/23  
 23,0 cm/9"



**SAROT**

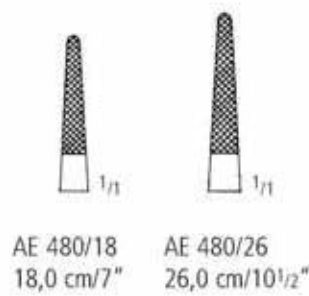

**MASSON**  
 AE 482/27  
 27,0 cm/10<sup>3</sup>/<sub>4</sub>"

AA  
 AB  
 AC  
 AD  
**AE**  
 AF  
 AK  
 AL  
 AO  
 KA  
 KK  
 X



**AE** NAHT SUTURE SUTURA SUTURE SUTURA

Nadelhalter mit Hartmetalleinsätzen  
 Needle Holders with Tungsten Carbide Inserts  
 Porta-agujas con bocas de carburo de Tungsteno  
 Porte-aiguilles à mors en carbure de tungstène  
 Portaghi con placche di carburo di tungsteno



**WERTHEIM**



AE 487/20  
20,0 cm/8"



AE 487/24  
24,0 cm/9 1/2"



AE 487/30  
30,0 cm/12"



AE 488/14  
14,0 cm/5 1/2"



AE 488/17  
17,0 cm/6 3/4"



AE 488/19  
19,0 cm/7 1/2"



AE 490/16  
16,0 cm/6 1/4"



AE 491/16  
16,0 cm/6 1/4"



**OLSEN-HEGAR**

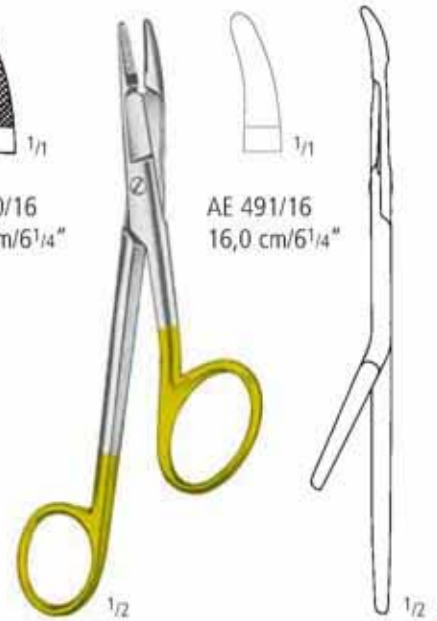

**GILLIES**

NAHT SUTURE SUTURA SUTURE SUTURA

Nadelhalter mit Hartmetalleinsätzen  
 Needle Holders with Tungsten Carbide Inserts  
 Porta-agujas con bocas de carburo de Tungsteno  
 Porte-aiguilles à mors en carbure de tungstène  
 Portaghi con placche di carburo di tungsteno

AA  
AB  
AC  
AD  
AE  
AF  
AK  
AL  
AO  
KA  
KK  
X



AE 500/14  
14,0 cm/5 1/2"



AE 500/17  
17,0 cm/6 3/4"



AE 500/20  
20,0 cm/8"



AE 500/24  
24,0 cm/9 1/2"

MATHIEU



AE 501/14  
14,0 cm/5 1/2"

MATHIEU



AE 502/17  
17,0 cm/6 3/4"



AE 502/20  
20,0 cm/8"



AE 502/23  
23,0 cm/9"

MATHIEU



AE 504/14  
14,0 cm/5 1/2"



AE 504/17  
17,0 cm/6 3/4"



AE 504/20  
20,0 cm/8"

MATHIEU-DELICATE



AE 507/17  
17,0 cm/6 3/4"



AE 507/19  
19,5 cm/7 1/2"

METZENBAUM

**AE** NAHT SUTURE SUTURA SUTURE SUTURA

Nadelhalter mit Hartmetalleinsätzen  
 Needle Holders with Tungsten Carbide Inserts  
 Porta-agujas con bocas de carburo de Tungsteno  
 Porte-aiguilles à mors en carbure de tungstène  
 Portaghi con placche di carburo di tungsteno



**MATHIEU-RYDER**



AE 510/17  
17,0 cm/6<sup>3</sup>/<sub>4</sub>"



AE 510/20  
20,0 cm/8"



AE 510/24  
24,0 cm/9<sup>1</sup>/<sub>2</sub>"



**MATHIEU-RYDER VASCULAR**



AE 512/17  
17,0 cm/6<sup>3</sup>/<sub>4</sub>"



AE 512/20  
20,0 cm/8"



AE 512/24  
24,0 cm/9<sup>1</sup>/<sub>2</sub>"

NAHT SUTURE SUTURA SUTURE SUTURA

Nadelhalter mit Hartmetalleinsätzen  
 Needle Holders with Tungsten Carbide Inserts  
 Porta-agujas con bocas de carburo de Tungsteno  
 Porte-aiguilles à mors en carbure de tungstène  
 Portaghi con placche di carburo di tungsteno

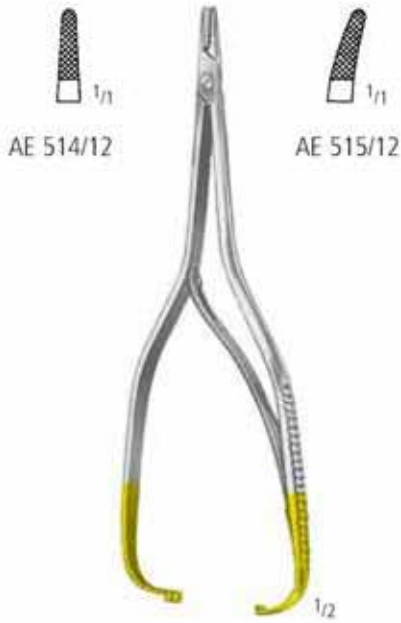

AE 514/12

AE 515/12



AE 516/16

AE 517/16



**BOYNTON**  
12,0 cm/4<sup>3</sup>/<sub>4</sub>"

**ARRUGA**  
16,0 cm/6<sup>1</sup>/<sub>4</sub>"



**HÖSEL**  
AE 520/25  
25,0 cm/10"



**TOENNIS**  
AE 522/18  
18,0 cm/7"



**LICHTENBERG**  
AE 524/20  
20,0 cm/8"

AA  
AB  
AC  
AD  
AE  
AF  
AK  
AL  
AO  
KA  
KK  
X

**AE** NAHT SUTURE SUTURA SUTURE SUTURA

Nadelhalter mit Hartmetalleinsätzen  
 Needle Holders with Tungsten Carbide Inserts  
 Porta-agujas con bocas de carburo de Tungsteno  
 Porte-aiguilles à mors en carbure de tungstène  
 Portaghi con placche di carburo di tungsteno



**ZWEIFEL**



AE 530/20  
20,0 cm/8"



AE 530/23  
23,0 cm/9"

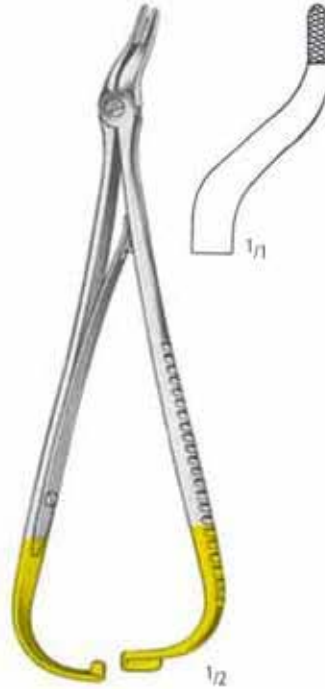

**EISELSBERG-MATHIEU**

AE 533/18  
18,5 cm/7<sup>1</sup>/<sub>3</sub>"



**LUETHY-BECK**

AE 535/20  
20,0 cm/8"



**LANGENBECK**



AE 540/16  
16,0 cm/6<sup>1</sup>/<sub>4</sub>"



AE 540/18  
18,0 cm/7"



AE 540/20  
20,0 cm/8"



AE 542/18  
18,0 cm/7"



AE 542/20  
20,0 cm/8"



AE 542/23  
23,0 cm/9"

**LANGENBECK-DELICATE**



AE 544/18  
18,0 cm/7"



AE 544/20  
20,0 cm/8"



AE 544/23  
23,0 cm/9"

**LANGENBECK-RYDER**



NAHT SUTURE SUTURA SUTURE SUTURA

Drahtzangen mit Hartmetalleinsätzen  
 Wire Twisting Forceps with Tungsten Carbide Inserts  
 Pinzas para torcer hilos con bocas de carburo de Tungsteno  
 Pincas à torsader le fil à mors en carbure de tungstène  
 Pinze per ritorcere fili con placche di carburo di tungsteno



STERNUM

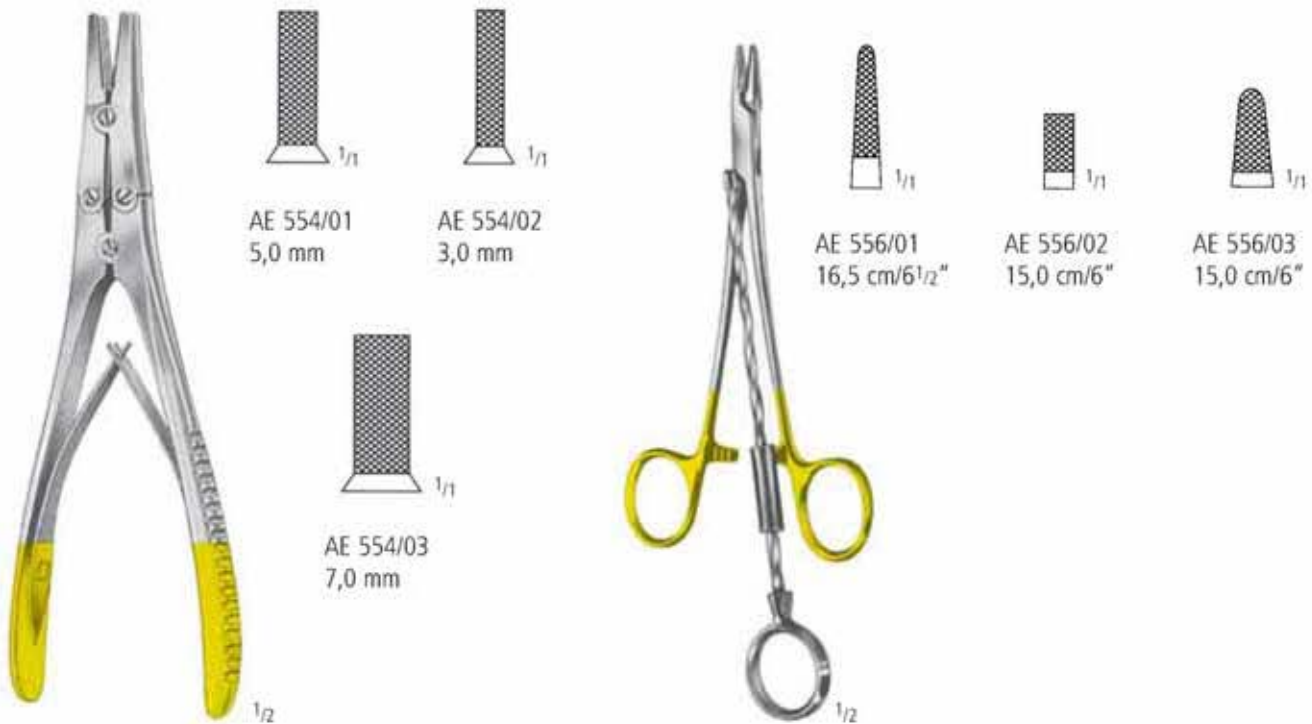

18,0 cm/7"

CORWIN

AA  
AB  
AC  
AD  
AE  
AF  
AK  
AL  
AO  
KA  
KK  
X

**AE** NAHT SUTURE SUTURA SUTURE SUTURA

Mikro-Nadelhalter mit Hartmetalleinsätzen  
 Micro-Needle Holders with Tungsten Carbide Inserts  
 Micro-Porta-agujas con bocas de carburo de Tungsteno  
 Micro-Porte-aiguilles à mors en carbure de tungstène  
 Micro-Portaghi con placche di carburo di tungsteno



**CASTROVIEJO**  
 14,0 cm/5 1/2"

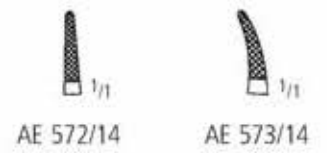

**CASTROVIEJO**  
 14,0 cm/5 1/2"

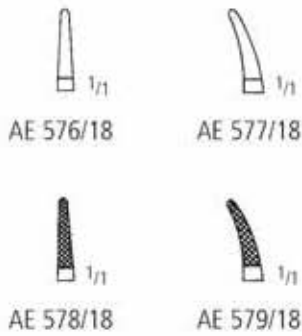

18,0 cm/7"



**JACOBSON**  
 21,0 cm/8 1/4"

NAHT SUTURE SUTURA SUTURE SUTURA

Mikro-Nadelhalter mit Hartmetalleinsätzen  
 Micro-Needle Holders with Tungsten Carbide Inserts  
 Micro-Porta-agujas con bocas de carburo de Tungsteno  
 Micro-Porte-aiguilles à mors en carbure de tungstène  
 Micro-Portaghi con placche di carburo di tungsteno



DIETRICH



AE 582/16  
16,0 cm/6 1/4"



AE 582/18  
18,0 cm/7"



AE 582/20  
20,0 cm/8"



AE 582/23  
23,0 cm/9"



AE 582/26  
26,0 cm/10 1/2"



KALT  
AE 584/14  
13,5 cm/5 1/4"



CASTROVIEJO  
AE 586/13  
13,0 cm/5"



POTTS-SMITH  
AE 588/22  
22,0 cm/8 3/4"

AA  
AB  
AC  
AD  
AE  
AF  
AK  
AL  
AO  
KA  
KK  
X

Nadelhalter  
Needle Holders  
Porta-agujas  
Porte-aiguilles  
Portaghi

nopa® DIAMOND



14,0 cm/5 1/2"



1/11

KS 080/14



1/11

18,0 cm/7"  
23,0 cm/9"

KS 080/18  
KS 080/23



14,0 cm/5 1/2"



1/11

KS 081/14



1/11

18,0 cm/7"  
23,0 cm/9"

KS 081/18  
KS 081/23

Nadelhalter  
Needle Holders  
Porta-agujas  
Porte-aiguilles  
Portaghi

nopa<sup>®</sup> DIAMOND



1/1  
21,0 cm/8 1/4"

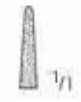

KS 082/21

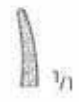

KS 083/21

- AA
- AB
- AC
- AD
- AE**
- AF
- AK
- AL
- AO
- KA
- KK
- X



**AE** NAHT SUTURE SUTURA SUTURE SUTURA

Mikro-Nadelhalter mit Rundgriff  
 Micro-Needle Holders with Pen-Type Handle  
 Micro-Porta-agujas con mango redondo  
 Micro-Porte-aiguilles à manches rondes  
 Micro-Portaghi con manici rotondi



**BARRAQUER-TROUTMAN**  
 AE 600/10  
 10,0 cm/4"



**BARRAQUER-TROUTMAN**  
 AE 601/10  
 10,0 cm/4"



**BARRAQUER-TROUTMAN**  
 AE 602/10  
 10,0 cm/4"



**BARRAQUER-TROUTMAN**  
 AE 603/10  
 10,0 cm/4"



**BARRAQUER**  
 AE 605/11  
 11,0 cm/4 1/3"



**BARRAQUER**  
 AE 605/13  
 13,0 cm/5"



**BARRAQUER**  
 AE 605/14  
 14,0 cm/5 1/2"



**BARRAQUER**  
 AE 606/14  
 14,0 cm/5 1/2"



**BARRAQUER**  
 AE 607/14  
 14,0 cm/5 1/2"

NAHT SUTURE SUTURA SUTURE SUTURA

Mikro-Nadelhalter mit Rundgriff  
 Micro-Needle Holders with Pen-Type Handle  
 Micro-Porta-agujas con mango redondo  
 Micro-Porte-aiguilles à manches rondes  
 Micro-Portaghi con manici rotondi

AA

AB

AC

AD

AE

AF

AK

AL

AO

KA

KK

X



**TROUTMAN**  
 AE 609/01  
 12,0 cm/4<sup>3</sup>/<sub>4</sub>"



**TROUTMAN**  
 AE 609/02  
 12,0 cm/4<sup>3</sup>/<sub>4</sub>"



**REILL**  
 15,0 cm/6"



**REILL**  
 15,0 cm/6"

**AE** NAHT SUTURE SUTURA SUTURE SUTURA

Mikro-Nadelhalter mit Rundgriff  
 Micro-Needle Holders with Pen-Type Handle  
 Micro-Porta-agujas con mango redondo  
 Micro-Porte-aiguilles à manches rondes  
 Micro-Portaghi con manici rotondi



AE 621/14  
 14,0 cm/5 1/2"



AE 623/14  
 14,0 cm/5 1/2"

...für Rechtshänder  
 ...for right handed surgeons  
 ...para diestros  
 ...pour des droitiers  
 ...per destrimanì

Maulteil konkav/konvex  
 Jaws concave/convex  
 Bocas concavas/convexas  
 Mors concave/convexe  
 Morso concavo/convesso



AE 625/14  
 14,0 cm/5 1/2"

...für Linkshänder  
 ...for left handed surgeons  
 ...para zurdos  
 ...pour gaucher  
 ...per manini

NAHT SUTURE SUTURA SUTURE SUTURA

Mikro-Nadelhalter mit Rundgriff  
 Micro-Needle Holders with Pen-Type Handle  
 Micro-Porta-agujas con mango redondo  
 Micro-Porte-aiguilles à manches rondes  
 Micro-Portaghi con manici rotondi



AE 630/18  
18,0 cm/7"



AE 631/18  
18,0 cm/7"



AE 632/18  
18,0 cm/7"



AE 633/18  
18,0 cm/7"

AA  
AB  
AC  
AD  
AE  
AF  
AK  
AL  
AO  
KA  
KK  
X

**AE** NAHT SUTURE SUTURA SUTURE SUTURA

Mikro-Nadelhalter  
 Micro-Needle Holders  
 Micro-Porta-agujas  
 Micro-Porte-aiguilles  
 Micro-Portaghi

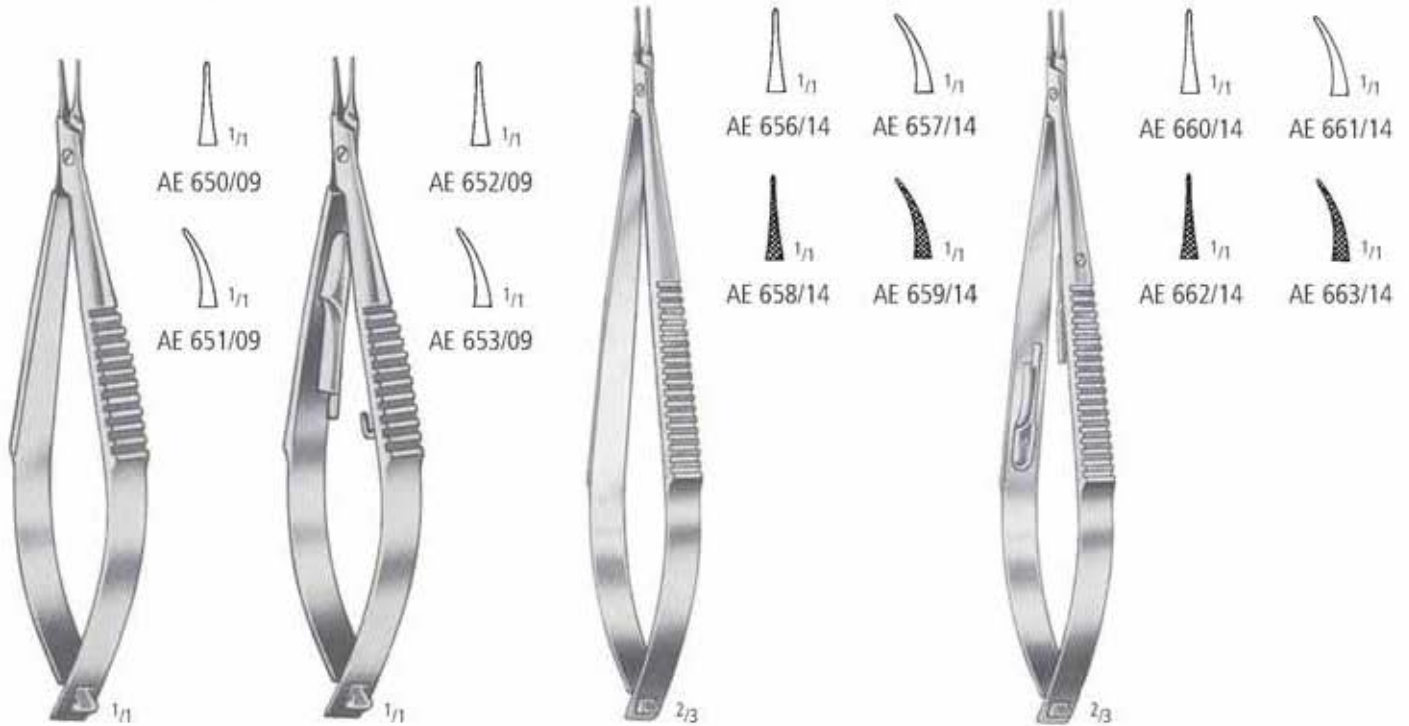

**CASTROVIEJO**  
 9,0 cm/3 1/2"

**CASTROVIEJO**  
 9,0 cm/3 1/2"

**CASTROVIEJO**  
 14,0 cm/5 1/2"

**CASTROVIEJO**  
 14,0 cm/5 1/2"

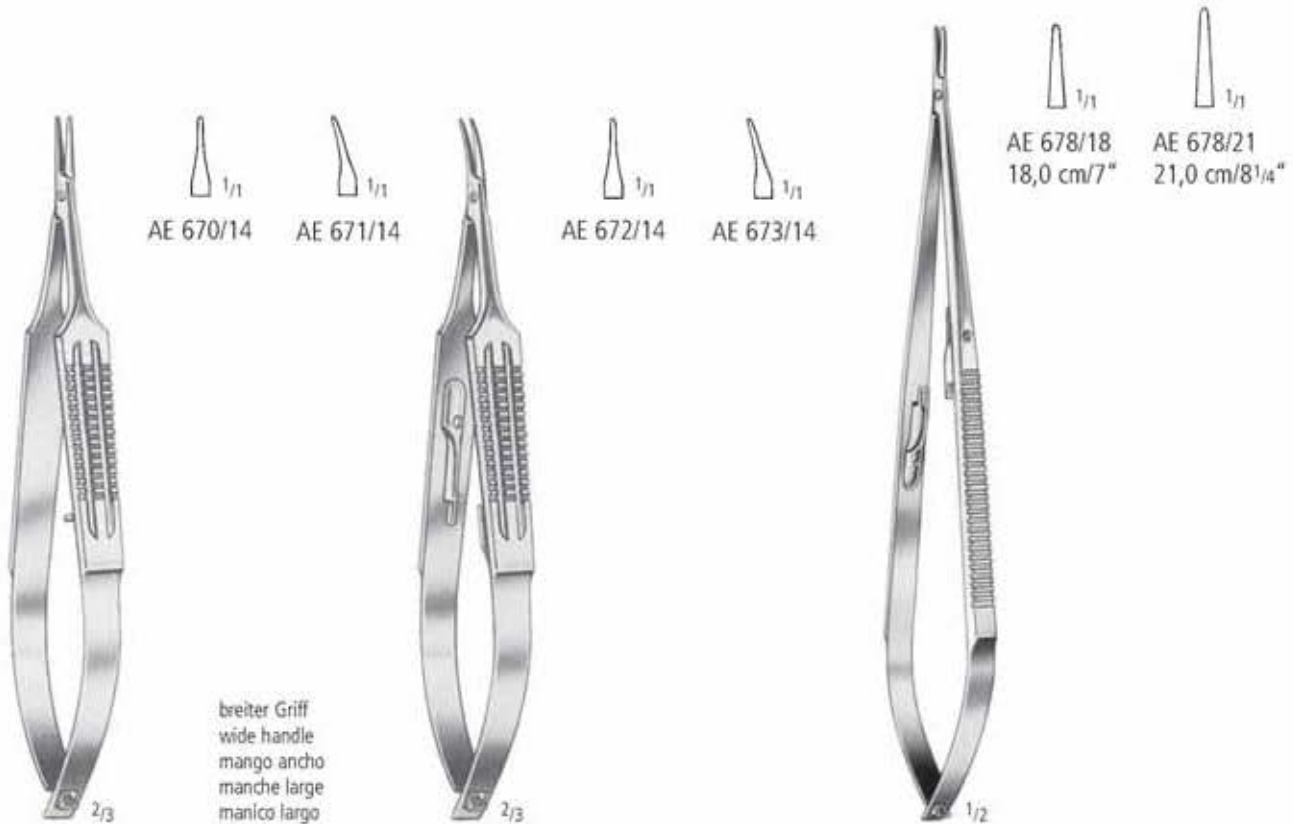

**CASTROVIEJO**  
 14,0 cm/5 1/2"

**CASTROVIEJO**  
 14,0 cm/5 1/2"

**JACOBSON**

breiter Griff  
 wide handle  
 mango ancho  
 manche large  
 manico largo



NAHT SUTURE SUTURA SUTURE SUTURA

Mikro-Nadelhalter  
 Micro-Needle Holders  
 Micro-Porta-agujas  
 Micro-Porte-aiguilles  
 Micro-Portaghi

AA

AB

AC

AD

AE

AF

AK

AL

AO

KA

KK

X



AE 680/16  
 AE 680/18  
 AE 680/20  
 AE 680/22

16,5 cm/6<sup>1</sup>/<sub>2</sub>"  
 18,0 cm/7"  
 20,0 cm/8"  
 22,0 cm/8<sup>3</sup>/<sub>4</sub>"



AE 681/16  
 AE 681/18  
 AE 681/20  
 AE 681/22



TUPFERZANGEN  
SPONGE FORCEPS  
PINZAS PARA POLIPOS  
PINCES A PANSEMENTS  
PINZE PER POLIPI

AF

nopa<sup>®</sup> instruments

Weitere Tupferzangen finden Sie in unserem Katalog "Allgemeine Chirurgie" in Gruppe AF.

For further sponge forceps kindly refer to our catalogue "General Surgery", section AF.

Para pinzas polipos adicionales, por favor consulte nuestro catálogo de "Cirugía general", grupo AF.

Pour des pinces à pansements supplémentaires, consultez notre catalogue "Chirurgie Generale", section AF.

Per gli altri pinze per polipi, consultare il nostro catalogo "Chirurgia Generale", gruppo AF.



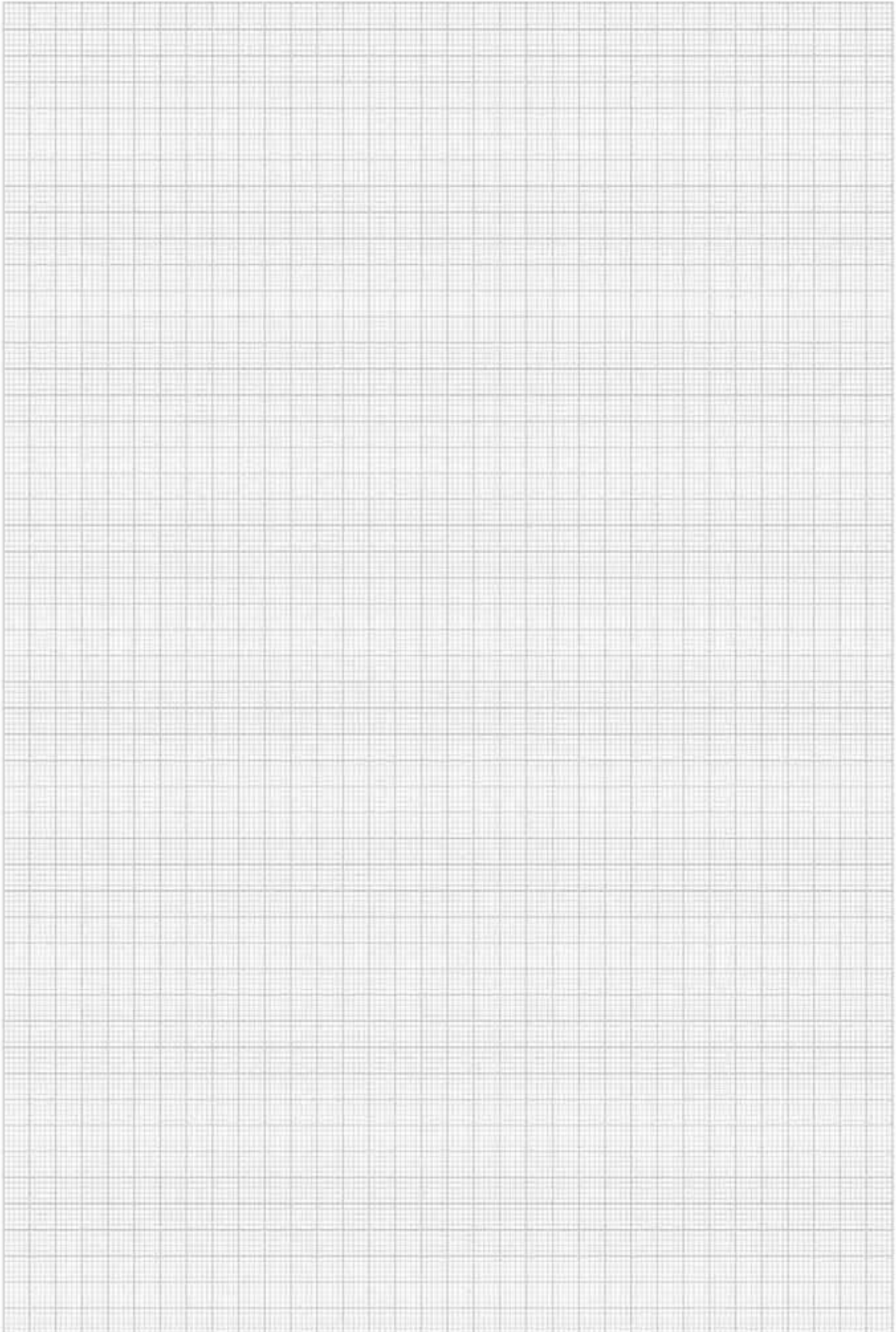

Korn- und Tupferzangen, Schwammzangen  
 Polypus and Dressing Forceps, Sponge Holding Forceps  
 Pinzas para pólipos, tapones y esponjas  
 Pincas à pansements, à tampons et à éponges  
 Pinze per polipi, tamponi e spugne

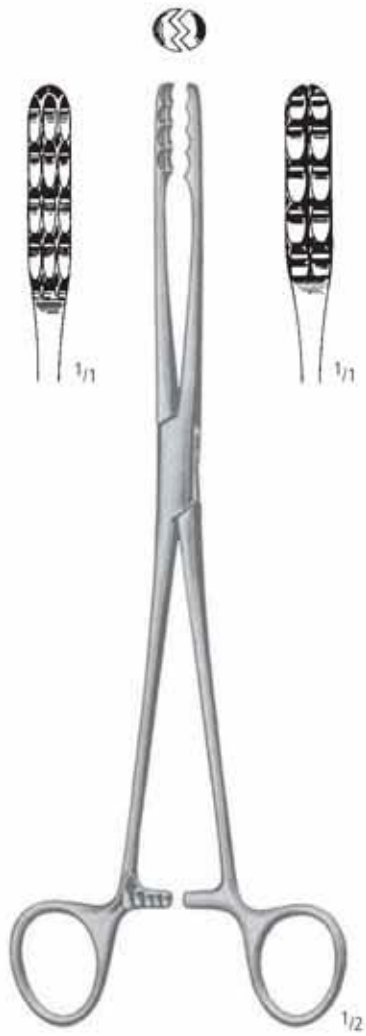

**ULRICH**  
 AF 070/22  
 AF 070/25

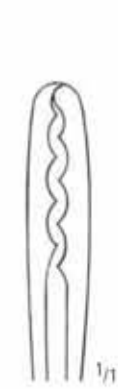

22,0 cm/8<sup>3</sup>/<sub>4</sub>"  
 25,0 cm/10"

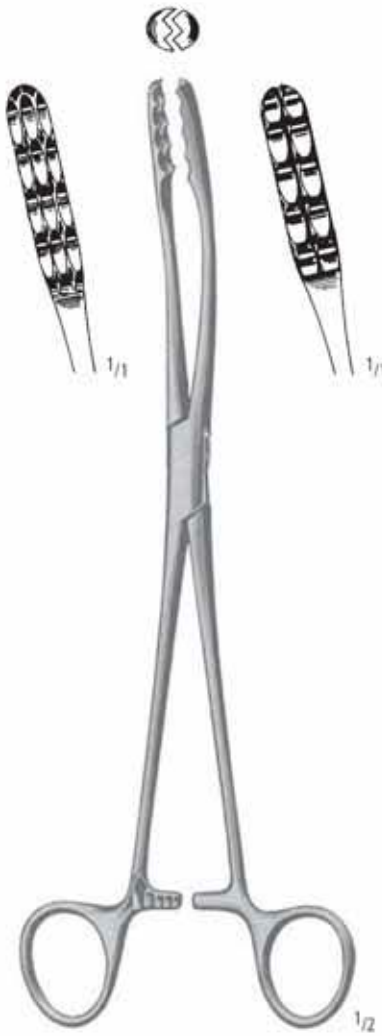

**ULRICH**  
 AF 071/22  
 AF 071/25



Korn- und Tupferzangen, Schwammzangen  
 Polypus and Dressing Forceps, Sponge Holding Forceps  
 Pinzas para pólipos, tapones y esponjas  
 Pincas à pansements, à tampons et à éponges  
 Pinze per polipi, tamponi e spugne



**GROSS-MAIER**

- AF 100/20
- AF 100/22
- AF 100/25
- AF 100/27

- 20,0 cm/8"
- 22,0 cm/8<sup>3</sup>/<sub>4</sub>"
- 25,0 cm/10"
- 27,0 cm/10<sup>3</sup>/<sub>4</sub>"



**GROSS-MAIER**

- AF 101/20
- AF 101/22
- AF 101/25
- AF 101/27

Korn- und Tupferzangen, Schwammzangen  
 Polypus and Dressing Forceps, Sponge Holding Forceps  
 Pinzas para pólipos, tapones y esponjas  
 Pincas à pansements, à tampons et à éponges  
 Pinze per polipi, tamponi e spugne

AA  
 AB  
 AC  
 AD  
 AE  
**AF**  
 AK  
 AL  
 AO  
 KA  
 KK  
 X



**GROSS-MAIER**

- AF 102/20
- AF 102/22
- AF 102/25
- AF 102/27

- 20,0 cm/8"
- 22,0 cm/8<sup>3</sup>/<sub>4</sub>"
- 25,0 cm/10"
- 27,0 cm/10<sup>3</sup>/<sub>4</sub>"



**GROSS-MAIER**

- AF 103/20
- AF 103/22
- AF 103/25
- AF 103/27

Korn- und Tupferzangen, Schwammzangen  
 Polypus and Dressing Forceps, Sponge Holding Forceps  
 Pinzas para pólipos, tapones y esponjas  
 Pincès à pansements, à tampons et à éponges  
 Pinze per polipi, tamponi e spugne



**FOERSTER-BALLENGER**



AF 200/18  
 AF 200/20

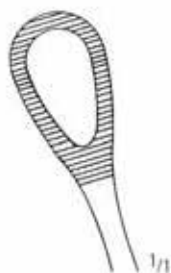

AF 201/18 18,0 cm/7"  
 AF 201/20 20,0 cm/8"



AF 202/18  
 AF 202/20



AF 203/18  
 AF 203/20



**FOERSTER-BALLENGER**

25,0 cm/10"



AF 200/25



AF 201/25



AF 202/25



AF 203/25

Korn- und Tupferzangen, Schwammzangen  
 Polypus and Dressing Forceps, Sponge Holding Forceps  
 Pinzas para pólipos, tapones y esponjas  
 Pincas à pansements, à tampons et à éponges  
 Pinze per polipi, tamponi e spugne

AA  
 AB  
 AC  
 AD  
 AE  
**AF**  
 AK  
 AL  
 AO  
 KA  
 KK  
 X







WUNDHAKEN  
RETRACTORS  
SEPARADORES  
ECARTEURS  
DIVARICATORI

AK

nopa<sup>®</sup> instruments

Weitere Wundhaken finden Sie in unserem Katalog "Allgemeine Chirurgie" in Gruppe AK.

For further retractors kindly refer to our catalogue "General Surgery", section AK.

Para separadores, por favor consulte nuestro catálogo de "Cirugía general", grupo AK.

Pour des ecarteurs, consultez notre catalogue "Chirurgie Generale", section AK.

Per gli altri divaricatori, consultare il nostro catalogo "Chirurgia Generale", gruppo AK.



**AK** WUNDHAKEN RETRACTORS SEPARADORES ECARTEURS DIVARICATORI

Feine Wundhaken  
Delicate Hooks  
Ganchos  
Crochets très fins  
Divaricatori sottili



**CUSHING**  
28,0 cm/11"



AK 034/01



AK 034/02



**CUSHING**  
19,0 cm/7<sup>1</sup>/<sub>2</sub>"



AK 036/01



AK 036/02



**MOLDESTAD**  
AK 038/13  
13,0 cm/5"



AK 040/05  
5 mm



AK 040/07  
7 mm

17,0 cm/6<sup>3</sup>/<sub>4</sub>"



AK 042/10  
Ø 1,0 mm



AK 042/12  
Ø 1,2 mm

18,5 cm/7<sup>1</sup>/<sub>3</sub>"



AK 044/11  
11,0 cm/4<sup>1</sup>/<sub>3</sub>"

WUNDHAKEN RETRACTORS SEPARADORES ECARTEURS DIVARICATORI

Feine Wundhaken  
Delicate Hooks  
Ganchos  
Crochets très fins  
Divaricatori sottili

AA  
AB  
AC  
AD  
AE  
AF  
AK  
AL  
AO  
KA  
KK  
X



AK 080/01  
18 x 7 mm

AK 080/03  
7 x 4 mm

AK 080/05  
7 x 4 mm

AK 080/02  
16 x 5 mm

AK 080/04  
10 x 3 mm

AK 080/06  
4 x 10 mm

**MEYERDING**  
18,0 cm/7"



AK 082/10  
10 x 6 mm

AK 082/20  
22 x 8 mm

**SENN-GREEN**  
15,0 cm/6"



AK 086/10  
10 x 6 mm

AK 086/17  
17 x 5 mm

AK 086/20  
20 x 6 mm

AK 086/22  
22 x 8 mm

**MINI-LANGENBECK**  
16,0 cm/6 1/4"

**AK** WUNDHAKEN RETRACTORS SEPARADORES ECARTEURS DIVARICATORI

Feine Wundhaken  
Delicate Hooks  
Ganchos  
Crochets très fins  
Divaricatori sottili



**DESMARRES**  
13,0 cm/5"



**DESMARRES**  
16,0 cm/6 1/4"

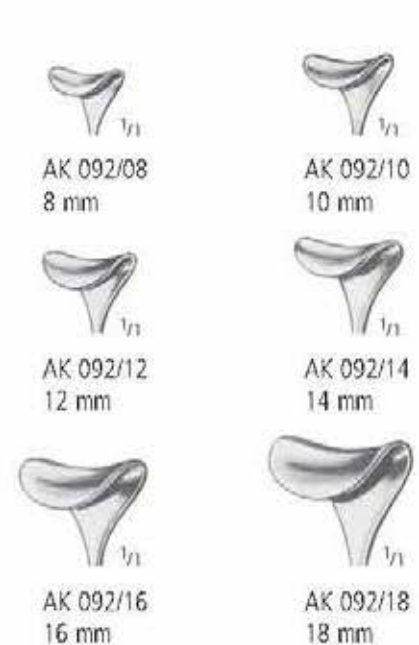

**CUSHING**  
20,0 cm/8"



**CUSHING**  
24,0 cm/9 1/2"

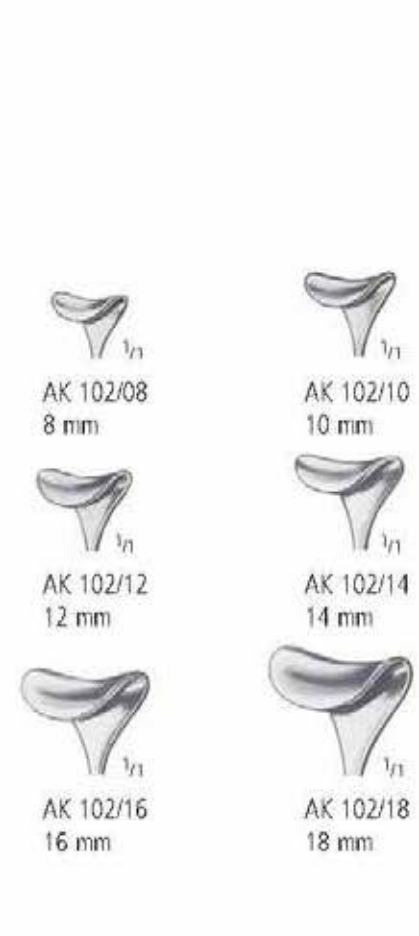

WUNDHAKEN RETRACTORS SEPARADORES ECARTEURS DIVARICATORI

Feine Wundhaken  
Delicate Hooks  
Ganchos  
Crochets très fins  
Divaricatori sottili

AA  
AB  
AC  
AD  
AE  
AF  
AK  
AL  
AO  
KA  
KK  
X





**AK** WUNDHAKEN RETRACTORS SEPARADORES ECARTEURS DIVARICATORI

Feine Wundhaken, Spinalhaken  
 Delicate Retractors, Spinal Retractors  
 Separadores finas, Separadores espinales  
 Ecarteurs fins, Ecarteurs spinals  
 Divaricatori sottili, Divaricatori spinali

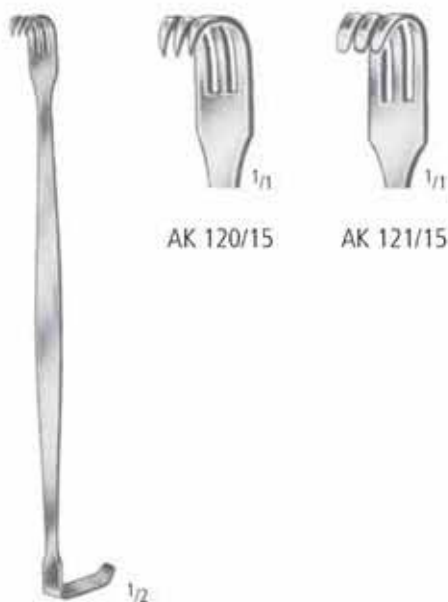

AK 120/15

AK 121/15

**BABY-SENN-MILLER**  
 15,0 cm/6"



AK 122/16

AK 123/16

**SENN-MILLER**  
 16,0 cm/6 1/4"



**RAGNELL-DAVIS**  
 AK 125/14  
 14,0 cm/5 1/2"



**CUSHING**  
 AK 130/20  
 20,0 cm/8"



**TAYLOR**  
 16,5 cm/6 1/2"

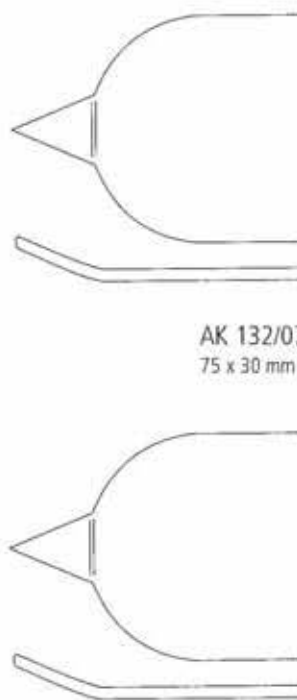

AK 132/07  
 75 x 30 mm

AK 132/10  
 100 x 30 mm

WUNDHAKEN RETRACTORS SEPARADORES ECARTEURS DIVARICATORI

AA  
AB  
AC  
AD  
AE  
AF  
AK  
AL  
AO  
KA  
KK  
X



1/2

**VOLKMANN**  
21,5 cm/8 1/2"



AK 150/01



AK 150/02



AK 150/03



AK 150/04



AK 150/06



1/1



AK 151/01



AK 151/02



AK 151/03



AK 151/04



AK 151/06



1/1



AK 152/01



AK 152/02



AK 152/03



AK 152/04



AK 152/06



1/1



1/2

**KOCHER**  
22,0 cm/8 3/4"



AK 160/01



AK 160/02



AK 160/03



AK 160/04



AK 160/06



AK 160/08



1/1



AK 161/01



AK 161/02



AK 161/03



AK 161/04



AK 161/06



AK 161/08



1/1



AK 162/01



AK 162/02



AK 162/03



AK 162/04



AK 162/06



AK 162/08



1/1



AK 170/21

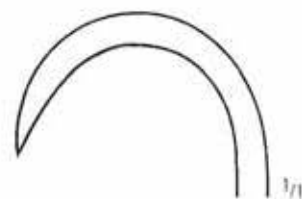

AK 172/20  
20,0 cm/8"



AK 171/21



AK 173/20  
20,0 cm/8"

**VOLKMANN**  
21,5 cm/8 1/2"



AK 180/08  
26 x 40 mm



AK 185/35  
35 x 40 mm



AK 185/43  
43 x 35 mm



AK 181/08  
26 x 40 mm



AK 185/45  
45 x 50 mm

**KOERTE**  
24,0 cm/9 1/2"

**BILLROTH**  
25,0 cm/10"



AK 210/40  
40 x 40 mm



AK 210/50  
45 x 50 mm

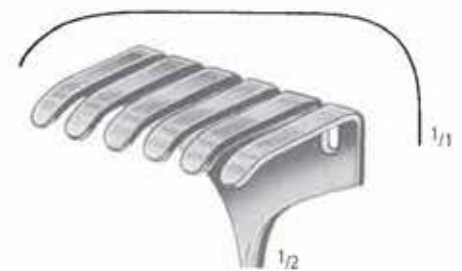

AK 210/60  
50 x 60 mm

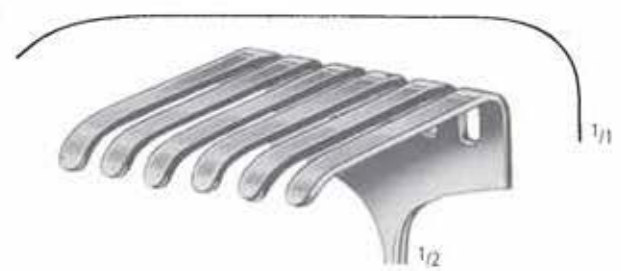

AK 210/70  
70 x 70 mm



AK 200/30  
36 x 30 mm

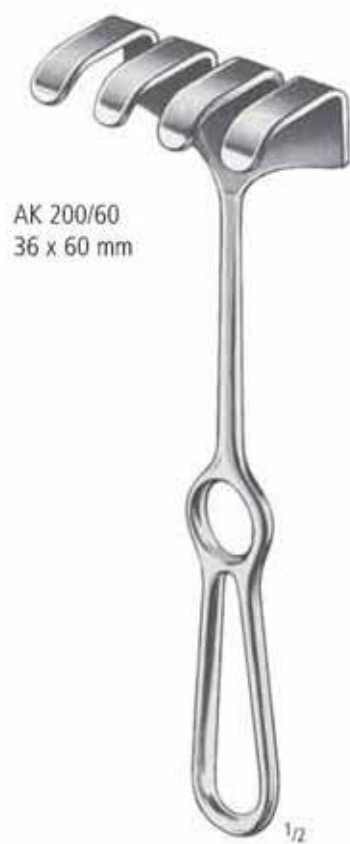

AK 200/60  
36 x 60 mm

**OLLIER**  
22,5 cm/9"



**ISRAEL**  
25,0 cm/10"



**LANGENBECK**  
21,0 cm/8<sup>1</sup>/<sub>4</sub>"

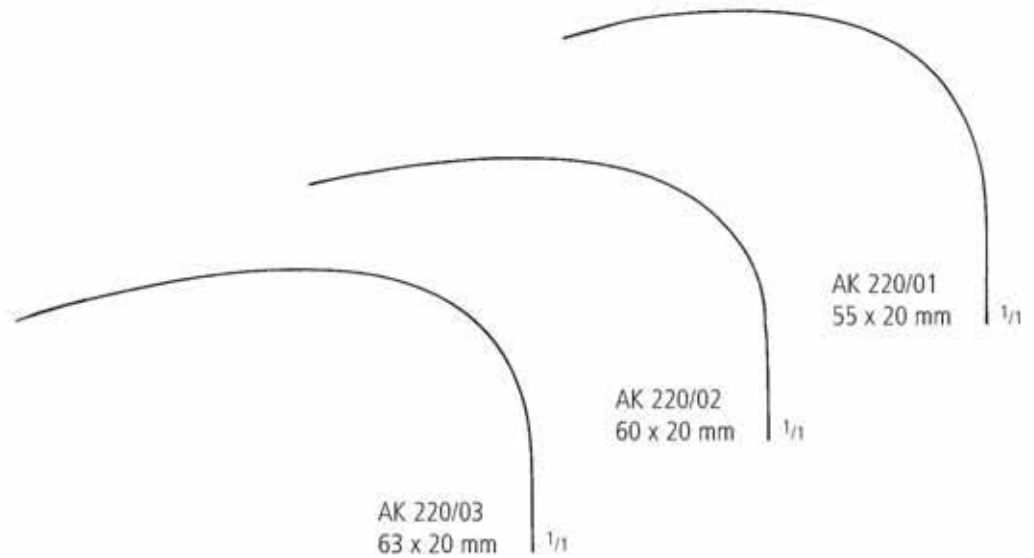

**LANGENBECK**  
AK 230/01-05  
22,0 cm/8<sup>3</sup>/<sub>4</sub>"



AK 230/01  
AK 231/01  
30 x 11 mm



AK 230/02  
AK 231/02  
30 x 14 mm



AK 230/03  
AK 231/03  
30 x 16 mm



AK 230/04  
AK 231/04  
40 x 11 mm



AK 230/05  
AK 231/05  
50 x 11 mm



**LANGENBECK**  
AK 231/01-05  
22,0 cm/8<sup>3</sup>/<sub>4</sub>"





**KOCHER-LANGENBECK**  
21,5 cm/8 1/2"



AK 233/01  
25 x 6 mm



AK 233/02  
35 x 8 mm



AK 233/03  
35 x 11 mm



AK 233/04  
35 x 15 mm



AK 233/05  
40 x 11 mm



AK 233/06  
55 x 11 mm



AK 233/07  
70 x 14 mm



AK 233/08  
80 x 12 mm



AK 233/09  
80 x 16 mm



**KOCHER**  
23,0 cm/9"

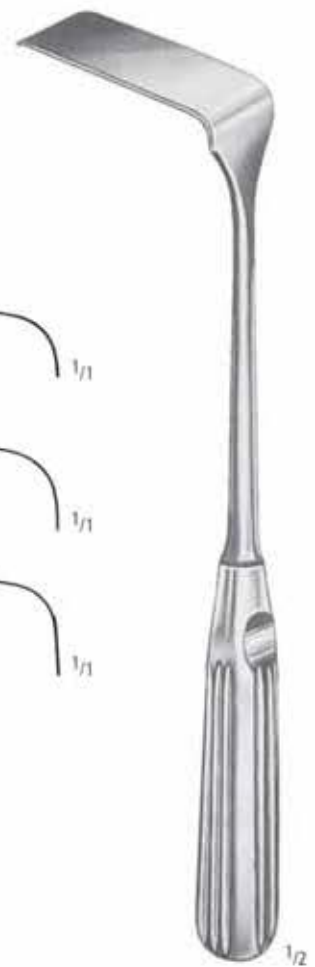
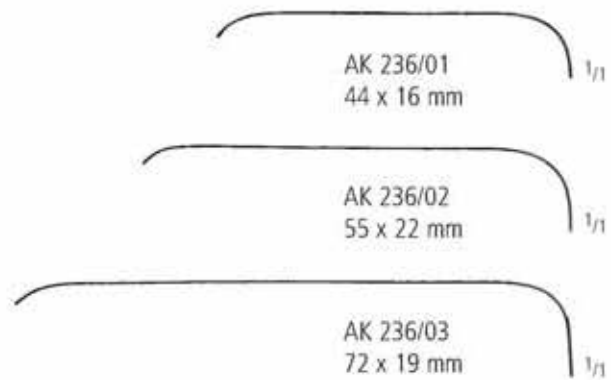
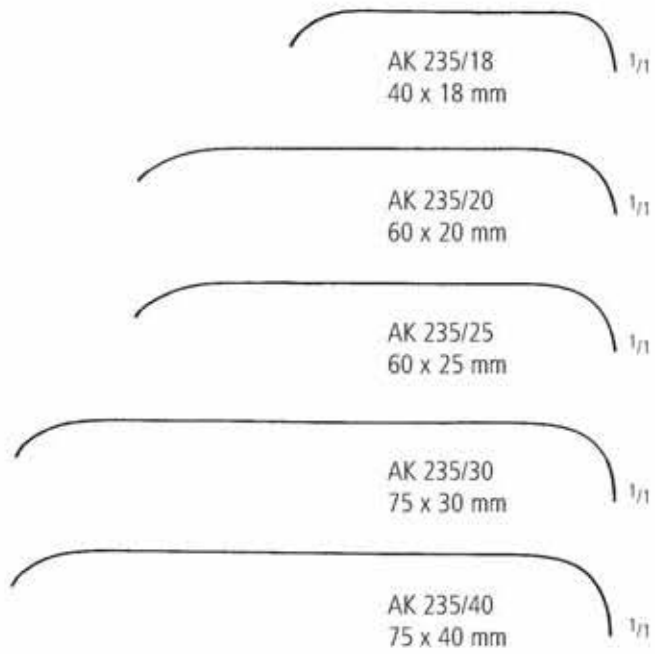

**SAUERBRUCH**  
22,5 cm/8<sup>3</sup>/<sub>4</sub>"



AK 237/01  
50 x 55 mm

**MORRIS**  
26,0 cm/10<sup>1</sup>/<sub>2</sub>"

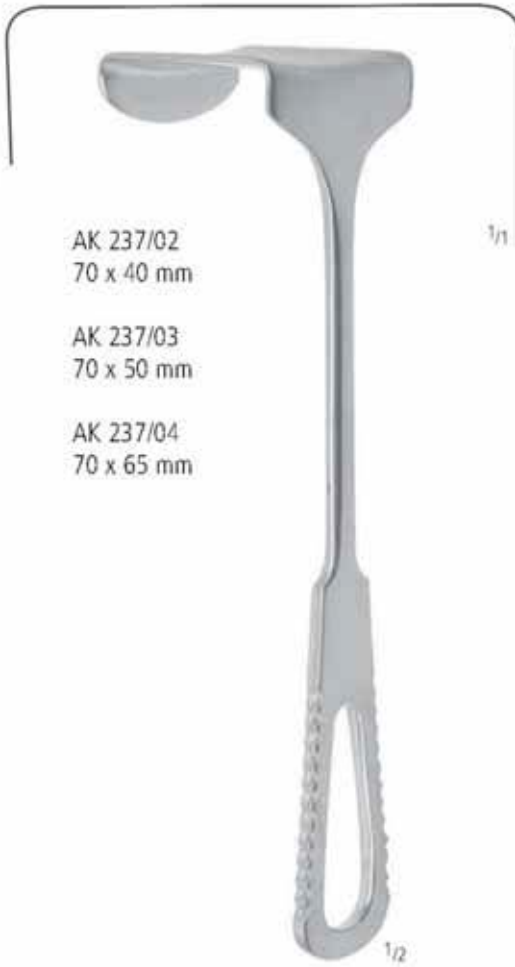

AK 237/02  
70 x 40 mm

AK 237/03  
70 x 50 mm

AK 237/04  
70 x 65 mm

**MORRIS**  
25 cm/10"



60 x 50 mm

60 x 45 mm

**MORRIS**  
AK 238/24  
25,0 cm/10"





**DOYEN**  
AK 280/25  
25,0 cm/10"

**TUFFIER**  
AK 282/23  
23,0 cm/9"

**HARRINGTON**  
32,0 cm/12<sup>3</sup>/<sub>4</sub>"  
127 x 40 mm AK 284/40  
127 x 62 mm AK 284/62  
175 x 64 mm AK 284/64





90 x 50 mm

**MIKULICZ**  
AK 286/26  
26,0 cm/10<sup>1</sup>/<sub>2</sub>"

**MIKULICZ**  
26,0 cm/10<sup>1</sup>/<sub>2</sub>"  
85 x 35 mm AK 290/01  
120 x 50 mm AK 290/02  
155 x 50 mm AK 290/03

**KELLY**  
27,0 cm/10<sup>3</sup>/<sub>4</sub>"  
160 x 38 mm AK 292/01  
160 x 57 mm AK 292/02  
190 x 38 mm AK 292/03  
190 x 57 mm AK 292/04



AA  
AB  
AC  
AD  
AE  
AF  
AK  
AL  
AO  
KA  
KK  
X



38 mm

**DEAVER**  
AK 300/07  
30,0 cm/12"



50 mm

**DEAVER**  
AK 300/08  
30,0 cm/12"



75 mm

**DEAVER**  
AK 300/09  
30,0 cm/12"



**DEAVER**  
AK 310/01-05

	B	L	
Fig. 1	25 mm	30,5 cm/12"	AK 310/01
Fig. 2	25 mm	33,0 cm/13"	AK 310/02
Fig. 3	38 mm	30,5 cm/12"	AK 310/03
Fig. 4	50 mm	30,5 cm/12"	AK 310/04
Fig. 5	75 mm	30,5 cm/12"	AK 310/05



**KOERTE**  
AK 312/28  
28,0 cm / 11"

fest  
rigid  
rigida  
rigide  
rigide

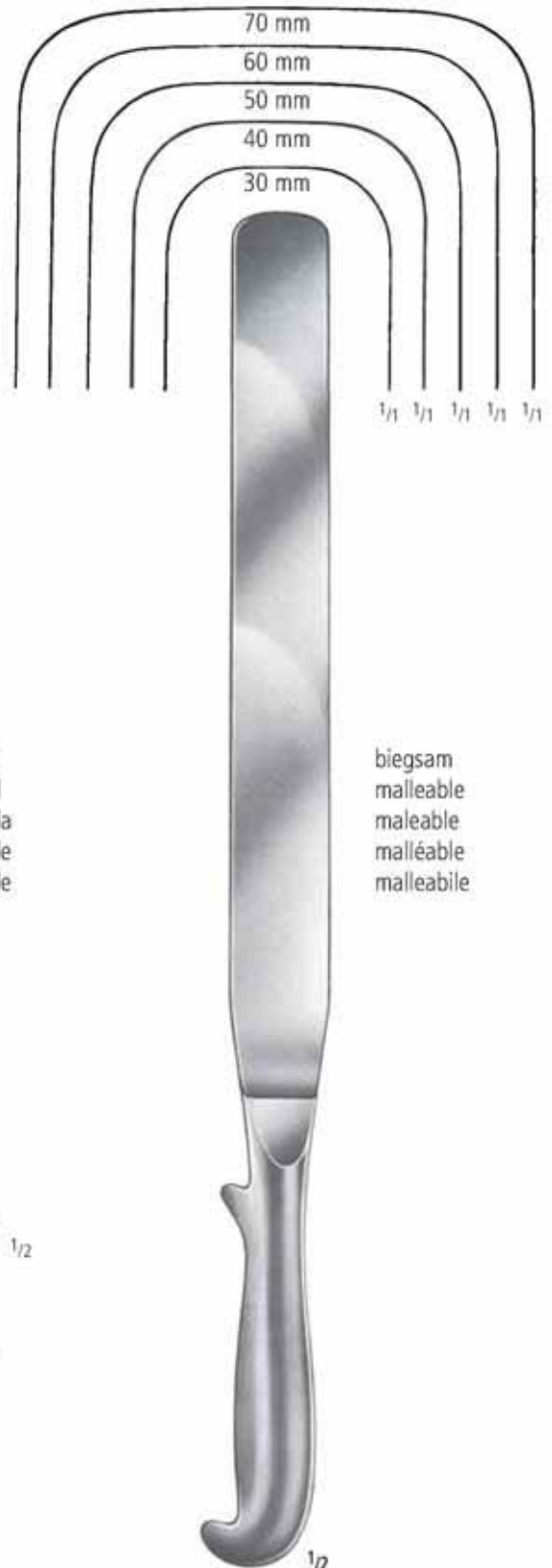

41,0 cm / 16"

245 x 30 mm	AK 315/30
245 x 40 mm	AK 315/40
245 x 50 mm	AK 315/50
245 x 60 mm	AK 315/60
245 x 70 mm	AK 315/70

biegsam  
malleable  
maleable  
malléable  
malleabile

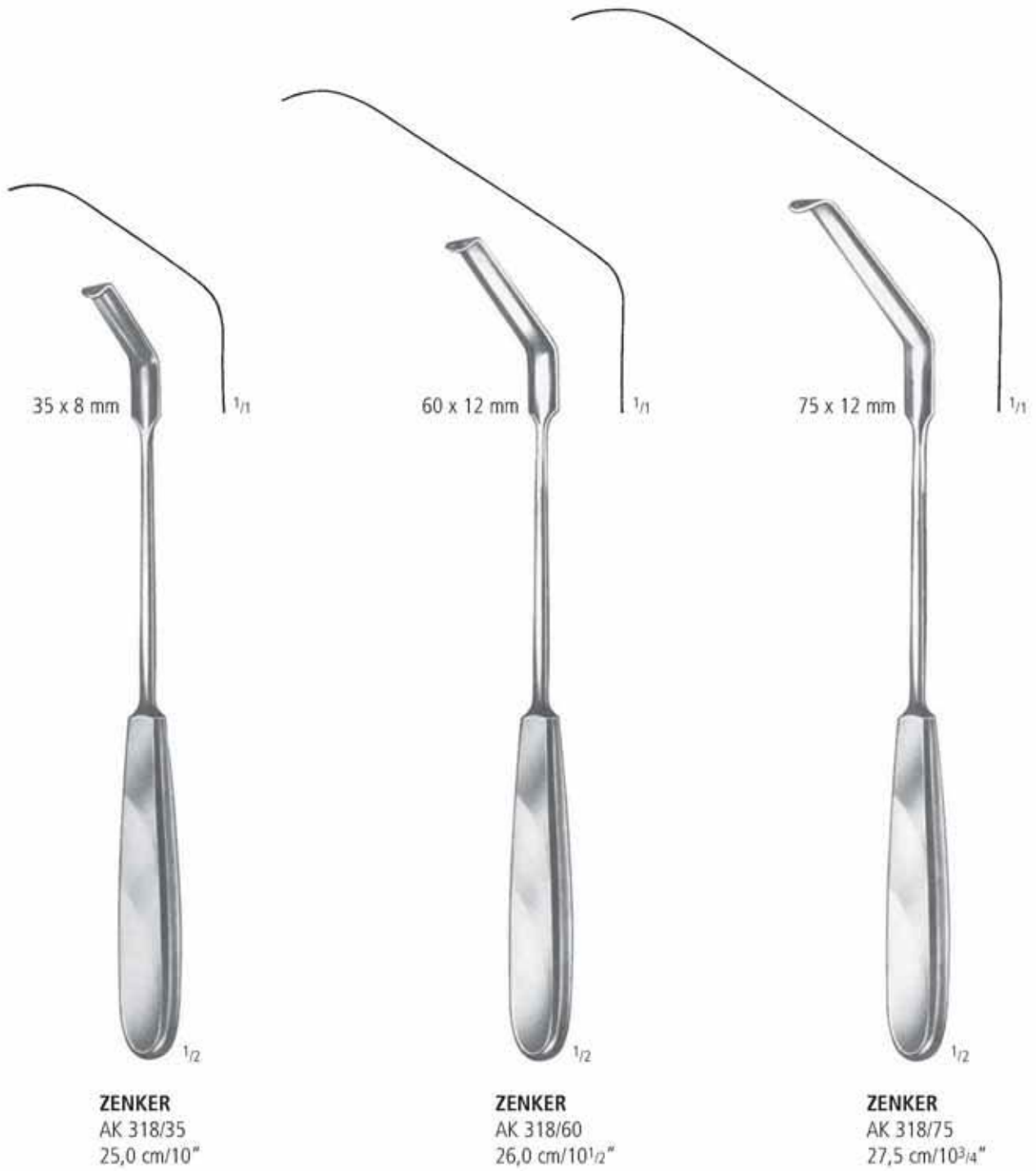



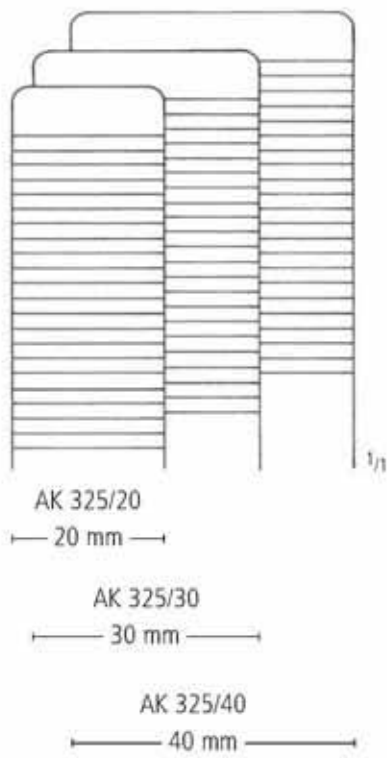

**KADER**  
27,0 cm/10<sup>3</sup>/<sub>4</sub>"



AK 328/22  
82 x 22 mm



AK 328/38  
115 x 38 mm



AK 328/65  
115 x 65 mm



130 x 38 mm

**CORYLLOS**  
24,0 cm/9 1/2"

**SAUERBRUCH**  
AK 330/25  
25,0 cm/10"



75 x 50 mm

**DAVIDSON**  
AK 337/50  
16,0 cm/6 1/4"



75 x 90 mm

**DAVIDSON**  
AK 337/90  
16,0 cm/6 1/4"

**AK** WUNDHAKEN RETRACTORS SEPARADORES ECARTEURS DIVARICATORI

Selbsthaltende Wundsperrer  
 Selfretaining Retractors  
 Separadores autoestaticos  
 Ecarteurs autostatiques  
 Divaricatori autostatici



**FINSEN**

	∧		∩
5,0 cm/2"	AK 500/05	AK 501/05	
7,0 cm/2 <sup>3</sup> / <sub>4</sub> "	AK 500/07	AK 501/07	



∧	∩
AK 502/10	AK 503/10
	10,0 cm/4"



**ALM**

	∧		∩
7,0 cm/2 <sup>3</sup> / <sub>4</sub> "	AK 506/07	AK 507/07	
10,0 cm/4"	AK 506/10	AK 507/10	



**JANSEN**

∧	∩
AK 510/10	AK 511/10
	10,0 cm/4"



**JANSEN**

∧	∩
AK 512/10	AK 513/10
	10,0 cm/4"



**SNITMAN**

∧	∩
AK 514/10	AK 515/10
	10,5 cm/4 <sup>1</sup> / <sub>4</sub> "

Selbsthaltende Wundsperrer  
Selfretaining Retractors  
Separadores autoestaticos  
Ecarteurs autostatiques  
Divaricatori autostatici

AA  
AB  
AC  
AD  
AE  
AF  
AK  
AL  
AO  
KA  
KK  
X

## WEITLANER



**WEITLANER-BABY**  
AK 519/14  
14,0 cm/5½"



**WEITLANER**  
AK 520/13      AK 521/13  
13,0 cm/5"



**WEITLANER**

10,5 cm/4¼"  
13,0 cm/5"  
16,5 cm/6½"  
20,0 cm/8"  
25,0 cm/10"  
26,0 cm/10½"

2 x 3  
3 x 4  
3 x 4  
3 x 4  
3 x 4  
5 x 6

^  
AK 522/10  
AK 524/13  
AK 526/16  
AK 528/20  
AK 530/25  
AK 532/26

∩  
AK 523/10  
AK 525/13  
AK 527/16  
AK 529/20  
AK 531/25  
AK 533/26



**AK** WUNDHAKEN RETRACTORS SEPARADORES ECARTEURS DIVARICATORI

Selbsthaltende Wundsperrer  
 Selfretaining Retractors  
 Separadores autoestaticos  
 Ecarteurs autostatiques  
 Divaricatori autostatici



**ADSON**  
 ^ AK 554/20    ^ AK 555/20  
 20,0 cm/8"



**ANDERSON-ADSON**  
 ^ AK 556/20    ^ AK 557/20  
 20,0 cm/8"



**ADSON**  
 ^ AK 558/27    ^ AK 559/27  
 27,0 cm/10<sup>3</sup>/<sub>4</sub>"

Selbsthaltende Wundsperrer  
Selfretaining Retractors  
Separadores autoestáticos  
Ecarteurs autostatiques  
Divaricatori autostatici



**ADSON**  
AK 560/27  
27,0 cm/10<sup>3</sup>/<sub>4</sub>"



**ADSON-R**  
AK 561/01  
27,0 cm/10<sup>3</sup>/<sub>4</sub>"



**ADSON-L**  
AK 561/02  
27,0 cm/10<sup>3</sup>/<sub>4</sub>"

Selbsthaltende Wundsperrer  
 Selfretaining Retractors  
 Separadores autoestaticos  
 Ecarteurs autostatiques  
 Divaricatori autostatici



**ADSON-BABY**  
 AK 562/14  
 14,0 cm/5 1/2"



**CONE**

13,0 cm/5"  
 16,5 cm/6 1/2"  
 20,0 cm/8"  
 25,0 cm/10"

3 x 4  
 3 x 4  
 3 x 4  
 3 x 4

^  
 AK 564/13  
 AK 564/16  
 AK 564/20  
 AK 564/25

∩  
 AK 565/13  
 AK 565/16  
 AK 565/20  
 AK 565/25

GEFÄSSINSTRUMENTE UND SONDEN  
VESSEL INSTRUMENTS AND PROBES  
INSTRUMENTAL VASCULAR Y SONDAS  
INSTRUMENTS VAISSEAUX ET SONDES  
STRUMENTI VASCOLARI E SONDE

AL

nopa<sup>®</sup> instruments

Weitere Sonden finden Sie in unserem Katalog  
"Allgemeine Chirurgie" in Gruppe AL.

For further probes kindly refer to our catalogue  
"General Surgery", section AL.

Para sondas adicionales, por favor consulte nuestro  
catálogo de "Cirugía general", grupo AL.

Pour des sondes supplémentaires, consultez notre  
catalogue "Chirurgie Generale", section AL.

Per gli altri sonde, consultare il nostro catalogo  
"Chirurgia Generale", gruppo AL.







SONDEN PROBES SONDAS SONDES SONDE

Sonden  
Probes  
Sondas  
Sondes  
Sonde

AA  
AB  
AC  
AD  
AE  
AF  
AK  
AL  
AO  
KA  
KK  
X



1/2



1/2



1/2

Silber  
silver  
de plata  
en argent  
d'argento



1/2

	1,0 mm	2,0 mm
11,5 cm/4 1/2"	AL 001/11	AL 002/11
13,0 cm/5"	AL 001/13	AL 002/13
14,5 cm/5 3/4"	AL 001/14	AL 002/14
16,0 cm/6 1/4"	AL 001/16	AL 002/16
18,0 cm/7"	AL 001/18	AL 002/18
20,0 cm/8"	AL 001/20	AL 002/20
25,0 cm/10"	AL 001/25	AL 002/25

AL 003/11  
AL 003/13  
AL 003/14  
AL 003/16  
AL 003/18  
AL 003/20  
AL 003/25

**MYRTLE LEAF**

AL 007/14  
AL 007/16  
AL 007/18  
AL 007/20

**STACKE**  
AL 013/10  
10,5 cm/4 1/4"  
Ø 1,0 mm



1/2



1/2

**DOYEN**

AL 017/14



1/2

AL 020/11  
AL 020/13  
AL 020/14  
AL 020/16  
AL 020/18



1/2

**NELATON**

AL 022/16

11,5 cm/4 1/2"	AL 015/11
13,0 cm/5"	AL 015/13
14,5 cm/5 3/4"	AL 015/14
16,0 cm/6 1/4"	AL 015/16
18,0 cm/7"	AL 015/18
20,0 cm/8"	AL 015/20

**AL** SONDEN PROBES SONDAS SONDES SONDE

Sonden und Watteträger  
 Probes and Cotton Applicators  
 Sondas y Porta-algodones  
 Sondes et Porte-coton  
 Sonde e Portacotone

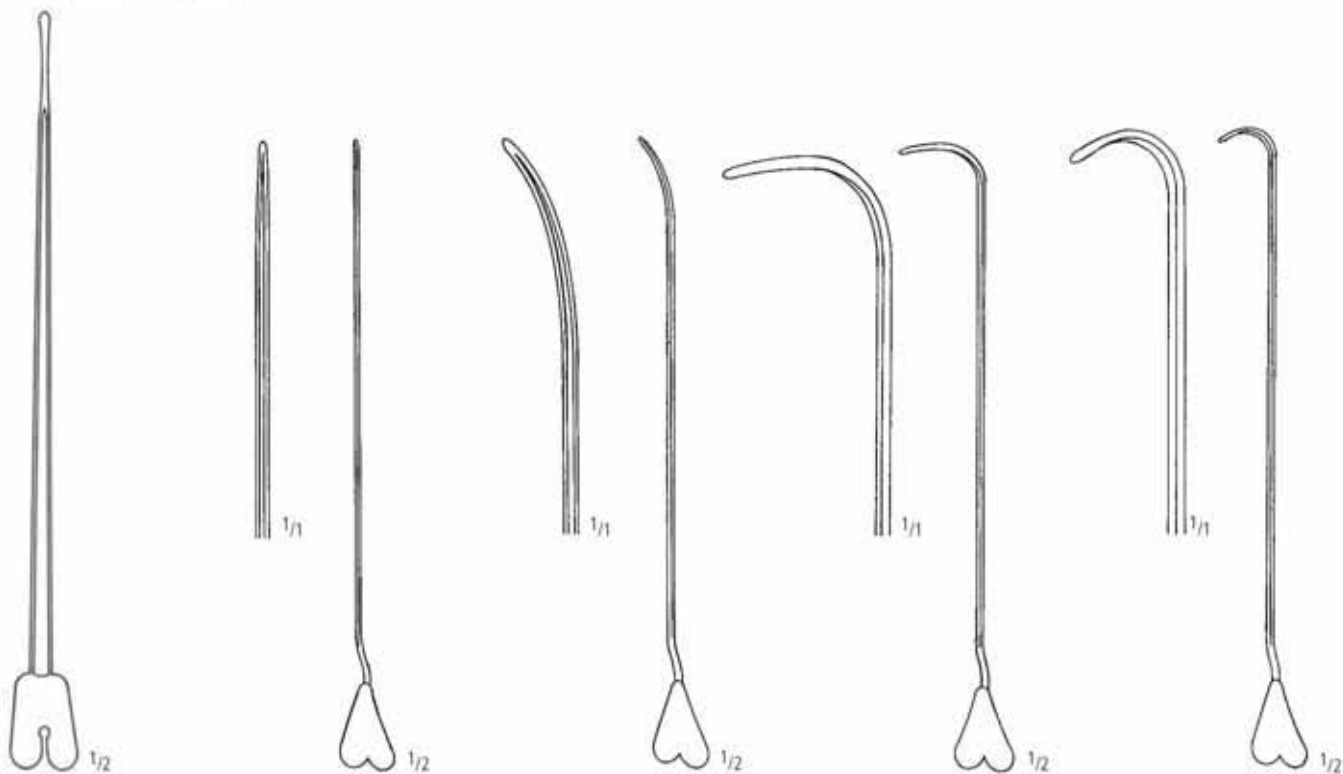

**BRODIE**

AL 026/20  
 20,0 cm/8"

**LOCKHART-MUMMERY**

Fig. 1  
 AL 030/01

Fig. 2  
 AL 030/02

**LOCKHART-MUMMERY**

Fig. 3  
 AL 030/03

Fig. 4  
 AL 030/04

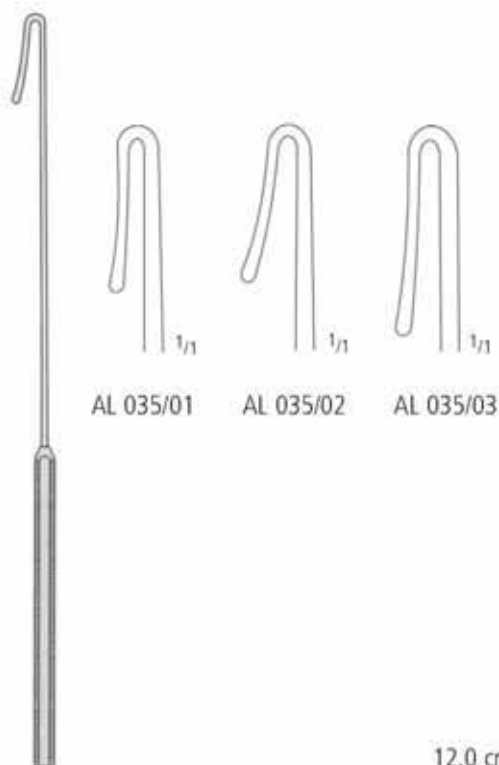

AL 035/01

AL 035/02

AL 035/03

**PRATT**

21,0 cm/8<sup>1</sup>/<sub>4</sub>"

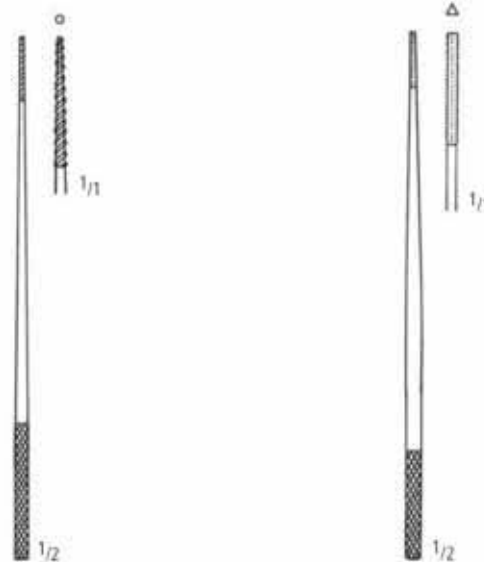

**FARRELL**

0,9 mm AL 100/12  
 1,1 mm AL 100/14

AL 100/16

1,2 mm

AL 100/18

**FARRELL**

0,9 mm AL 120/12  
 1,1 mm AL 120/14

AL 120/16

1,2 mm

AL 120/18

SONDEN PROBES SONDAS SONDES SONDE

Watteträger und Krampfader-Besteck  
 Cotton Applicators and Varicose Vein Probe Set  
 Porta-algodones y sonda para várices  
 Porte-coton et trousse à varices  
 Portacotone e astuccio per vanci

AA  
AB  
AC  
AD  
AE  
AF  
AK  
AL  
AO  
KA  
KK  
X

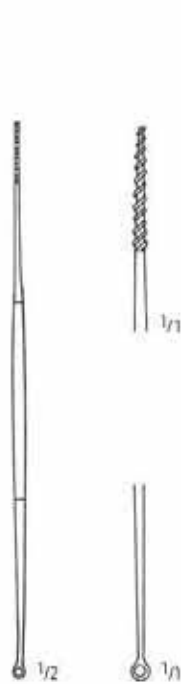

**UCKERMANN**  
 AL 160/16  
 16,0 cm/6 1/4"

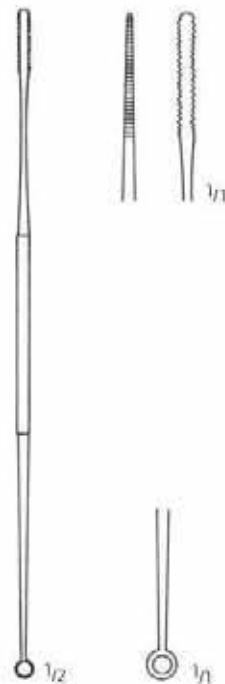

**JOBSON-HORNE**  
 AL 162/18  
 18,0 cm/7"

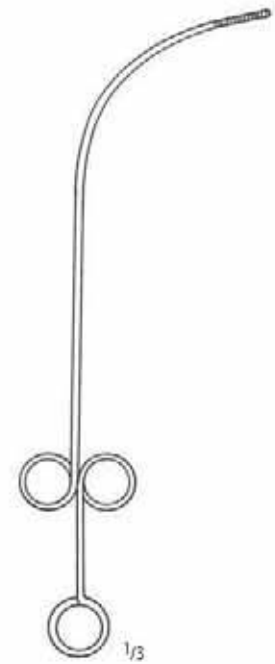

**FEIN**  
 AL 170/28  
 28,0 cm/11"

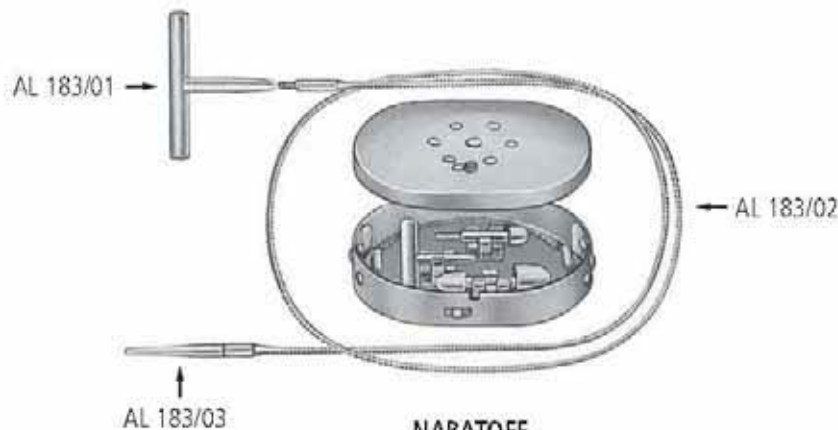

**NABATOFF**  
 AL 180/00  
 komplett-complete-completo-complet-completo

**AL** SONDEN PROBES SONDAS SONDES SONDE

Gefäß-Dilatatoren  
 Vascular Dilators  
 Diladores vasculares  
 Dilateurs vasculaires  
 Dilatori per vasi

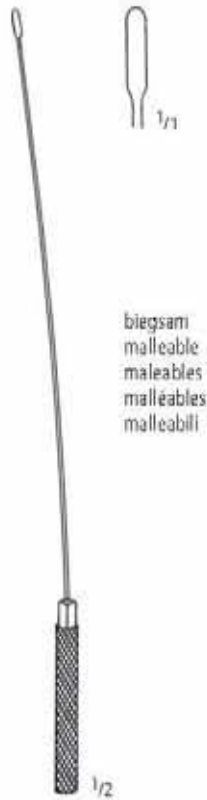

biegsam  
 malleable  
 maleables  
 malleables  
 malleabili

	14,0 cm/5 1/2"	21,0 cm/8 1/4"
1,0 mm	AL 190/10	AL 192/10
1,5 mm	AL 190/15	AL 192/15
2,0 mm	AL 190/20	AL 192/20
2,5 mm	AL 190/25	AL 192/25
3,0 mm	AL 190/30	AL 192/30
3,5 mm	AL 190/35	AL 192/35
4,0 mm	AL 190/40	AL 192/40
4,5 mm	AL 190/45	AL 192/45
5,0 mm	AL 190/50	AL 192/50

**GARRETT**

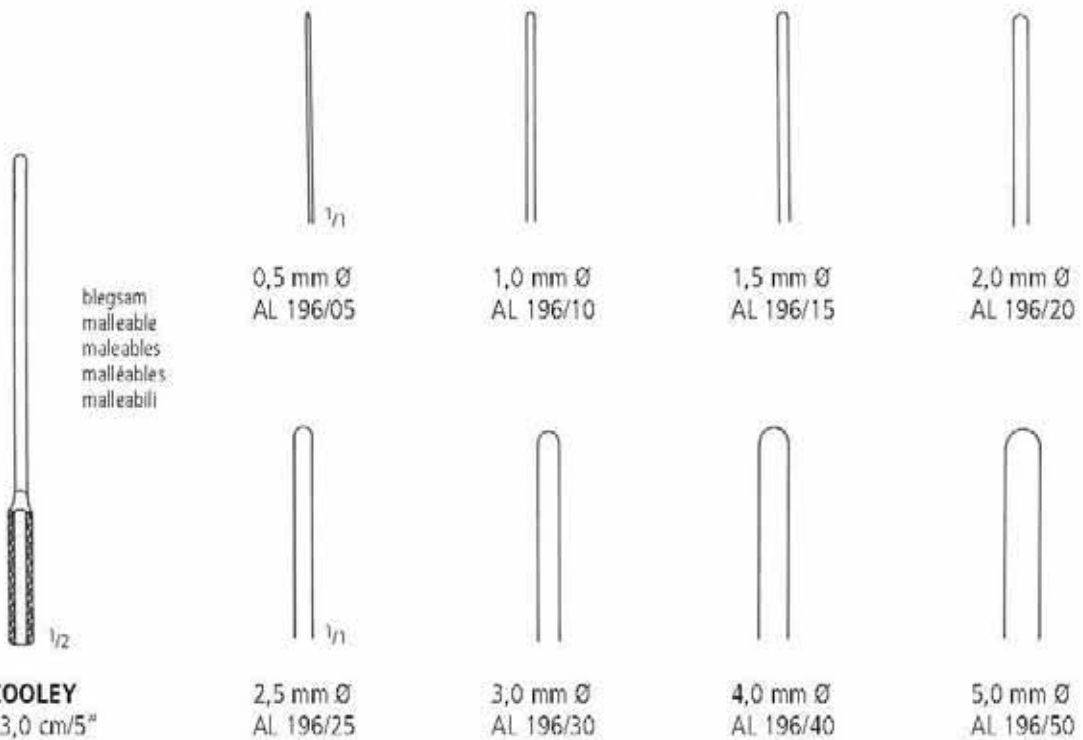

biegsam  
 malleable  
 maleables  
 malleables  
 malleabili

0,5 mm Ø AL 196/05	1,0 mm Ø AL 196/10	1,5 mm Ø AL 196/15	2,0 mm Ø AL 196/20
2,5 mm Ø AL 196/25	3,0 mm Ø AL 196/30	4,0 mm Ø AL 196/40	5,0 mm Ø AL 196/50

**COOLEY**  
 13,0 cm/5"

SONDEN PROBES SONDAS SONDES SONDE

Gefäß-Dilatatoren  
 Vascular Dilators  
 Dilatadores vasculares  
 Dilatateurs vasculaires  
 Dilatatori per vasi

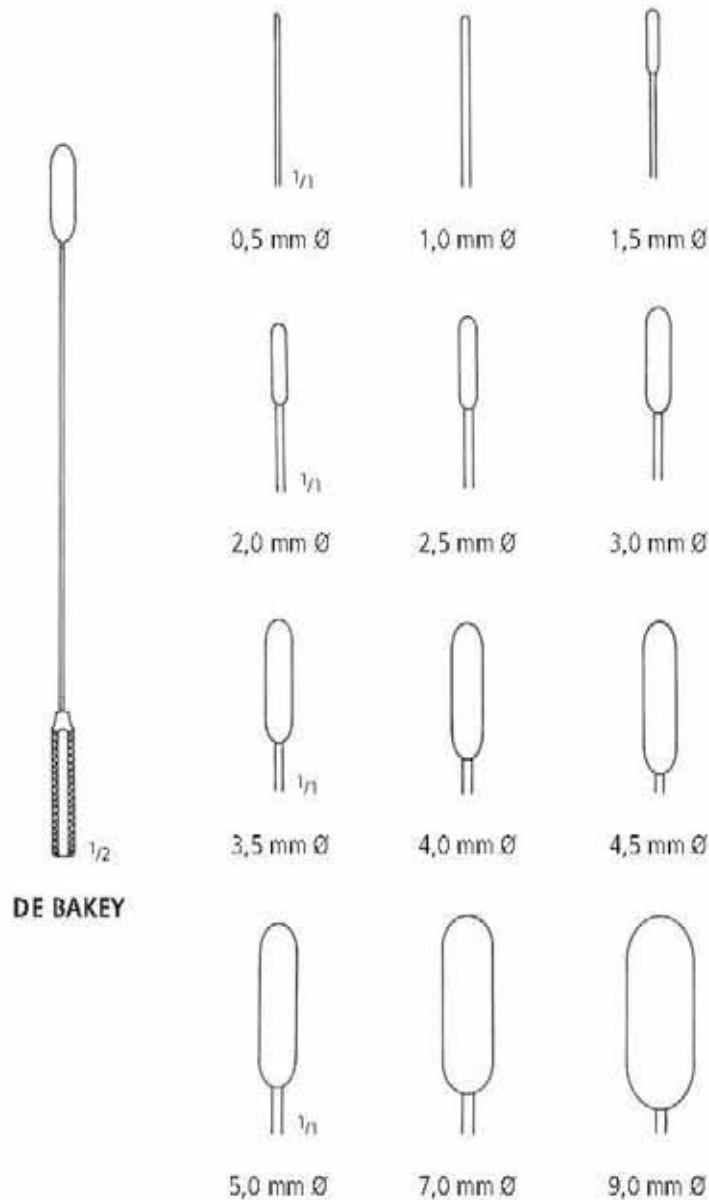

DE BAKEY

biegsam-malleable-maleables-malléables-malleabili

mm Ø	19,0 cm / 7 1/2"	35,0 cm / 14"
0,5	AL 200/05	AL 201/05
1,0	AL 200/10	AL 201/10
1,5	AL 200/15	AL 201/15
2,0	AL 200/20	AL 201/20
2,5	AL 200/25	AL 201/25
3,0	AL 200/30	AL 201/30
3,5	AL 200/35	AL 201/35
4,0	AL 200/40	AL 201/40
4,5	AL 200/45	AL 201/45
5,0	AL 200/50	AL 201/50
7,0	AL 200/70	AL 201/70
9,0	AL 200/90	AL 201/90

AA  
AB  
AC  
AD  
AE  
AF  
AK  
AL  
AO  
KA  
KK  
X



**AL** SONDEN PROBES SONDAS SONDES SONDE

Gefäß-Stripper  
 Vascular Strippers  
 Desobliteradores de vasos  
 Tira veines  
 Tiravene



50,0 cm / 20"



2,0 mm  
 AL 220/02



6,0 mm  
 AL 220/06



10,0 mm  
 AL 220/10



3,0 mm  
 AL 220/03



7,0 mm  
 AL 220/07



12,0 mm  
 AL 220/12



4,0 mm  
 AL 220/04



8,5 mm  
 AL 220/08

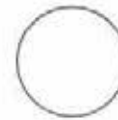

14,0 mm  
 AL 220/14



1/2

AL 222/12  
 12,0 cm / 4<sup>3</sup>/<sub>4</sub>"

SONDEN PROBES SONDAS SONDES SONDE

Fasszangen  
 Grasping forceps  
 Pinzas para coger  
 Pincas pour saisir  
 Pinze per afferrare



**FRANKENFELDT**  
 AL 248/36  
 36,0 cm / 14 1/4"



38,0 cm / 15 1/4"



AL 250/38

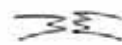

AL 251/38



AL 252/38

AA  
 AB  
 AC  
 AD  
 AE  
 AF  
 AK  
**AL**  
 AO  
 KA  
 KK  
 X

- 1,0 mm KB 100/02
- 2,0 mm KB 100/04
- 3,0 mm KB 100/06
- 4,0 mm KB 100/08
- 5,0 mm KB 100/10
- 6,0 mm KB 100/12
- 7,0 mm KB 100/14
- 8,0 mm KB 100/16
- 9,0 mm KB 100/18
- 10,0 mm KB 100/20
- 11,0 mm KB 100/22
- 12,0 mm KB 100/24
- 13,0 mm KB 100/26
- 14,0 mm KB 100/28
- 15,0 mm KB 100/30
- 16,0 mm KB 100/32
- 17,0 mm KB 100/34
- 18,0 mm KB 100/36
- 19,0 mm KB 100/38
- 20,0 mm KB 100/40
- 21,0 mm KB 100/42
- 22,0 mm KB 100/44
- 23,0 mm KB 100/46
- 24,0 mm KB 100/48
- 25,0 mm KB 100/50
- 26,0 mm KB 100/52
- 27,0 mm KB 100/54
- 28,0 mm KB 100/56
- 29,0 mm KB 100/58
- 30,0 mm KB 100/60

- 1,5 mm KB 100/03
- 2,5 mm KB 100/05
- 3,5 mm KB 100/07
- 4,5 mm KB 100/09
- 5,5 mm KB 100/11
- 6,5 mm KB 100/13
- 7,5 mm KB 100/15
- 8,5 mm KB 100/17
- 9,5 mm KB 100/19
- 10,5 mm KB 100/21
- 11,5 mm KB 100/23
- 12,5 mm KB 100/25
- 13,5 mm KB 100/27
- 14,5 mm KB 100/29
- 15,5 mm KB 100/31
- 16,5 mm KB 100/33
- 17,5 mm KB 100/35
- 18,5 mm KB 100/37
- 19,5 mm KB 100/39



HEGAR

**KB 110/14**

Satz zu 14 Dilatoren 4,0 mm - 17,0 mm  
 Set of 14 dilators 4,0 mm - 17,0 mm  
 Juego de 14 dilatadores 4,0 mm - 17,0 mm  
 Jeu de 14 dilateurs 4,0 mm - 17,0 mm  
 Serie di 14 dilatatori 4,0 mm - 17,0 mm

**KB 110/26**

Satz zu 26 Dilatoren 1,0 mm - 26,0 mm  
 Set of 26 dilators 1,0 mm - 26,0 mm  
 Juego de 26 dilatadores 1,0 mm - 26,0 mm  
 Jeu de 26 dilateurs 1,0 mm - 26,0 mm  
 Serie di 26 dilatatori 1,0 mm - 26,0 mm

**KB 112/14**

Satz zu 14 Dilatoren 4,0 mm - 17,0 mm  
 Set of 14 dilators 4,0 mm - 17,0 mm  
 Juego de 14 dilatadores 4,0 mm - 17,0 mm  
 Jeu de 14 dilateurs 4,0 mm - 17,0 mm  
 Serie di 14 dilatatori 4,0 mm - 17,0 mm



HEGAR



HEGAR

1,0/ 2,0 mm	KB 113/02
3,0/ 4,0 mm	KB 113/04
5,0/ 6,0 mm	KB 113/06
7,0/ 8,0 mm	KB 113/08
9,0/10,0 mm	KB 113/10
11,0/12,0 mm	KB 113/12
13,0/14,0 mm	KB 113/14
15,0/16,0 mm	KB 113/16
17,0/18,0 mm	KB 113/18
19,0/20,0 mm	KB 113/20
21,0/22,0 mm	KB 113/22
23,0/24,0 mm	KB 113/24
25,0/26,0 mm	KB 113/26

**KB 114/08**

Satz zu 8 Dilatatoren 3,0/4,0 mm - 17,0/18,0 mm  
 Set of 8 dilators 3,0/4,0 mm - 17,0/18,0 mm  
 Juego 8 dilatadores 3,0/4,0 mm - 17,0/18,0 mm  
 Jeu de 8 dilateurs 3,0/4,0 mm - 17,0/18,0 mm  
 Serie di 8 dilatatori 3,0/4,0 mm - 17,0/18,0 mm

**KB 114/13**

Satz zu 13 Dilatatoren 1,0/2,0 mm - 25,0/26,0 mm  
 Set of 13 dilators 1,0/2,0 mm - 25,0/26,0 mm  
 Juego de 13 dilatadores 1,0/2,0 mm - 25,0/26,0 mm  
 Jeu de 13 dilateurs 1,0/2,0 mm - 25,0/26,0 mm  
 Serie di 13 dilatatori 1,0/2,0 mm - 25,0/26,0 mm



HEGAR

**KB 115/08**

Satz zu 8 Dilatatoren 3,0/4,0 mm - 17,0/18,0 mm  
 Set of 8 dilators 3,0/4,0 mm - 17,0/18,0 mm  
 Juego 8 dilatadores 3,0/4,0 mm - 17,0/18,0 mm  
 Jeu de 8 dilateurs 3,0/4,0 mm - 17,0/18,0 mm  
 Serie di 8 dilatatori 3,0/4,0 mm - 17,0/18,0 mm





SAUGROHRE UND KANÜLEN  
SUCTION TUBES AND CANNULAE  
TUBOS DE ASPIRACION Y CANULAS  
TUBES D'ASPIRATION ET CANULES  
TUBI D'ASPIRAZIONE E CANNULE

AO

nopa<sup>®</sup> instruments

Weitere Instrumente für den Bereiche AO finden Sie in unserem Katalog "Allgemeine Chirurgie" in der Gruppe AO.

For further instruments of the section AO kindly refer to our catalogue "General Surgery", section AO.

Para instrumentos adicionales del este grupo AO, por favor consulte nuestro catálogo de "Cirugía general", grupo AO.

Pour instruments supplémentaires AO, consultez notre catalogue "Chirurgie Generale", section AO.

Per altri strumenti de questo gruppo AO, consultare il nostro catalogo "Chirurgia Generale", gruppo AO.





Saugrohre  
Suction Tubes  
Tubos de aspiración  
Canules d'aspiration  
Cannule per aspirazione

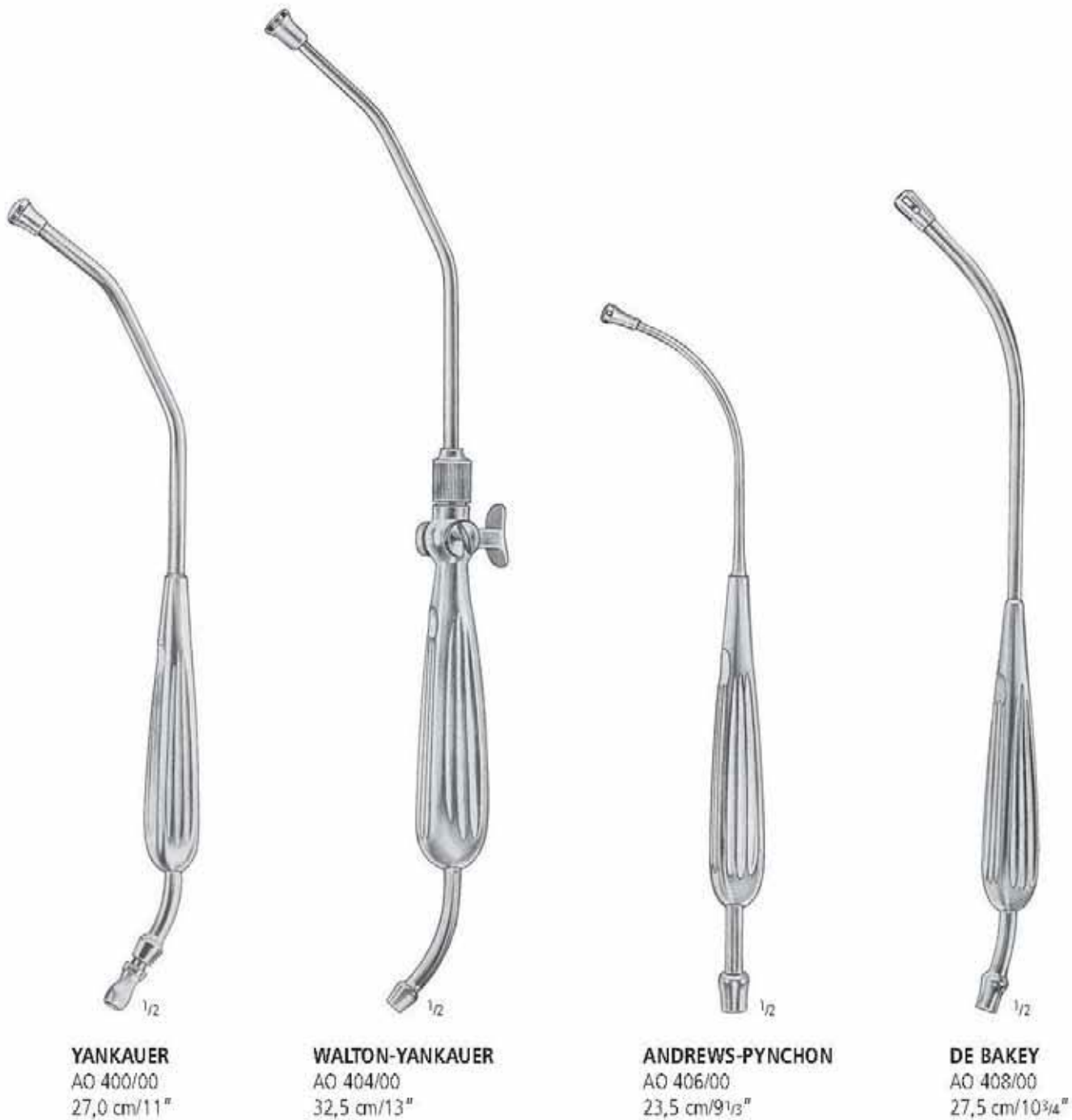

AA  
AB  
AC  
AD  
AE  
AF  
AK  
AL  
AO  
KA  
KK  
X

Saugrohre  
Suction Tubes  
Tubos de aspiración  
Canules d'aspiration  
Cannule per aspirazione



**COUPLAND**  
AO 410/00



**BYRD**  
1,5 mm AO 412/15  
2,5 mm AO 412/25  
3,5 mm AO 412/35



**POOLE**  
AO 420/22  
10,0 mm



**POOLE**  
AO 421/22  
8,0 mm



**BABY-POOLE**  
AO 422/20  
5,5 mm

Saugrohre  
Suction Tubes  
Tubos de aspiración  
Canules d'aspiration  
Cannule per aspirazione

AA  
AB  
AC  
AD  
AE  
AF  
AK  
AL  
AO  
KA  
KK  
X

8,0 mm



**COOLEY**  
AO 424/01  
33,0 cm/13"

8,0 mm



**COOLEY**  
AO 424/02  
35,0 cm/14"

6,0 mm



**COOLEY**  
AO 424/03  
30,0 cm/12"

10,0 mm



**COOLEY**  
AO 424/04  
31,0 cm/12 1/4"



Saugrohre  
Suction Tubes  
Tubos de aspiración  
Canules d'aspiration  
Cannule per aspirazione



**FRAZIER**

6 Charr.	AO 430/06
8 Charr.	AO 430/08
10 Charr.	AO 430/10
12 Charr.	AO 430/12

**PLESTER**

1,5 mm	AO 432/15
2,0 mm	AO 432/20
2,5 mm	AO 432/25
3,0 mm	AO 432/30

**FERGUSSON**

5 Charr.	AO 434/05
6 Charr.	AO 434/06
7 Charr.	AO 434/07
8 Charr.	AO 434/08
9 Charr.	AO 434/09
10 Charr.	AO 434/10
12 Charr.	AO 434/12

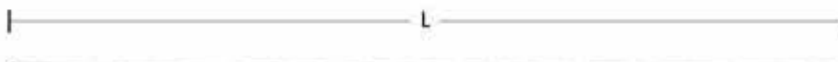

	<b>L</b>	<b>L</b>	<b>L</b>	<b>L</b>
	130 mm	150 mm	180 mm	220 mm
Ø 1,5 mm	AO 440/13	AO 440/15	AO 440/18	AO 440/22
Ø 2,0 mm	AO 441/13	AO 441/15	AO 441/18	AO 441/22
Ø 2,5 mm	AO 442/13	AO 442/15	AO 442/18	AO 442/22
Ø 3,5 mm	AO 443/13	AO 443/15	AO 443/18	AO 443/22



**ADSON**  
AO 450/04  
21,0 cm/8<sup>1</sup>/<sub>4</sub>"  
Ø 4,0 mm

KNOCHENINSTRUMENTE  
BONE INSTRUMENTS  
INSTUMENTOS PARA HUESOS  
INSTRUMENTS DES OS  
STRUMENTI PER OSSA

KA

nopa<sup>®</sup> instruments

Bohrapparate u. Zubehör	Seite	219-221
Drilling devices and accessories	Page	219-221
Taladradoras y accesorios	Página	219-221
Perceuses et accessoires	Page	219-221
Alesatrici e accessori	Pagina	219-221
Drahtzangen	Seite	222-223
Wire forceps	Page	222-223
Pinzas para hilos	Página	222-223
Pinces à fil	Page	222-223
Tenaglie fili	Pagina	222-223
Hohlmeißel- und Knochensplitterzangen	Seite	224-232
Bone rongeurs and bone cutting forceps	Page	224-232
Pinzas gubias y pinzas cortantes para huesos	Página	224-232
Pinces gouges et pinces coupantes à os	Page	224-232
Pinze sgorbie e pinze cesoie per ossa	Pagina	224-232





Bohrapparate und Zubehör  
 Drilling devices and accessories  
 Taladradoras y accesorios  
 Perceuses et accessoires  
 Alesatrici e accessori



KA 120/00  
 Akku Bohrrapparat / Akku power drill

Spannung / Voltage	9,6 Volt
Drehzahl / Revolutions	0-750 U/min
Leistung / Power	130/200 Watt



KA 121/00  
 Luft Bohrrapparat / Air power drill

Drehzahl / Revolutions	600 U/min
Druck / Compression	6,5 bar

AA  
 AB  
 AC  
 AD  
 AE  
 AF  
 AK  
 AL  
 AO  
**KA**  
 KK  
 X

Zubehör für KA 120/00 und KA 121/00  
 Accessories for KA 120/00 and KA 121/00  
 Accesorios para KA 120/00 y KA 121/00  
 Accessoires pour KA 120/00 et KA 121/00  
 Accessori per KA 120/00 e KA 121/00



KA 122/10  
 Adapter mit Jacobs Spannfutter  
 Adapter with Jacobs chuck



KA 122/16  
 Schnellspannfutter für Kirschnerdrähte 0,8 bis 3,0 mm  
 Quick-action chuck for Kirschner wires 0,8 to 3,0 mm



KA 122/11  
 Adapter für AO Schaft  
 Adapter for AO shank



KA 123/01  
 Osteotomie Säge oszillierend  
 Sagittal saw oscillating



KA 122/13  
 Adapter für DIN Schaft  
 Adapter for DIN shank



KA 123/02  
 Sternum Säge  
 Sternum Saw



KA 122/14  
 Adapter für Harris Schaft  
 Adapter for Harris shank



KA 122/15  
 Adapter für Hudson Schaft  
 Adapter for Hudson shank

Ladegerät / Akku  
 Charger / Battery  
 Cargador / acumulador  
 Chargeur d'accus / accumulateur  
 Caricabatteria / accumulatore



KA 124/01  
 Ladegerät Netzspannung 115V / 240V Ladezeit 60 min  
 Charger main voltage 115V / 240V charging time 60 min



KA 124/02  
 Ladegerät für 2 Akkus Netzspannung 115V / 240V  
 Ladezeit 60 min  
 Charger for 2 batteries main voltage 115V / 240V  
 Charging time 60 min



KA 124/10  
 9,6V 2600mAh



KA 124/11  
 12V 2600mAh

AA  
 AB  
 AC  
 AD  
 AE  
 AF  
 AK  
 AL  
 AO  
**KA**  
 KK  
 X



Drahtzangen  
Wire Forceps  
Pinzas para hilos  
Pinces à fil  
Tenaglie fili



KA 270/15  
15,0 cm/6"



KA 271/16  
16 cm/6<sup>1</sup>/<sub>4</sub>"



KA 272/18  
18,0 cm/7"

für weiche Drähte bis 2,0 mm Ø  
for soft wires up to 2,0 mm Ø  
para hilos blandos hasta 2,0 mm de Ø  
pour fils mous jusqu'à 2,0 mm de Ø  
per fili morbidi sino a mm. 2,0 di Ø

für harte Drähte bis 1,5 mm Ø  
for hard wires up to 1,5 mm Ø  
para hilos duros hasta 1,5 mm de Ø  
pour fils durs jusqu'à 1,5 mm de Ø  
per fili duri sino a mm. 1,5 di Ø

nopa  
**TUC<sup>®</sup>**

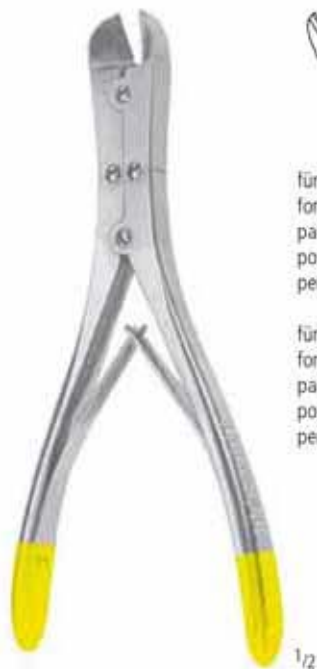

KA 273/17  
17,0 cm/6<sup>3</sup>/<sub>4</sub>"



für weiche Drähte bis 2,0 mm Ø  
for soft wires up to 2,0 mm Ø  
para hilos blandos hasta 2,0 mm de Ø  
pour fils mous jusqu'à 2,0 mm de Ø  
per fili morbidi sino a mm. 2,0 di Ø

für harte Drähte bis 1,6 mm Ø  
for hard wires up to 1,6 mm Ø  
para hilos duros hasta 1,6 mm de Ø  
pour fils durs jusqu'à 1,6 mm de Ø  
per fili duri sino a mm. 1,6 di Ø



KA 273/22  
22 cm/8<sup>3</sup>/<sub>4</sub>"

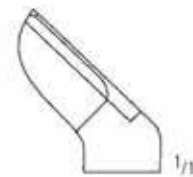

für Drähte bis 2,5 mm Ø  
for wires up to 2,5 mm Ø  
para hilos hasta 2,5 mm de Ø  
pour fils jusqu'à 2,5 mm de Ø  
per fili sino a mm. 2,5 di Ø

Drahtzangen  
Wire forceps  
Pinzas para hilos  
Pincas à fil  
Tenaglie fili



KA 275/47  
47,0 cm/18 1/2"

AA  
AB  
AC  
AD  
AE  
AF  
AK  
AL  
AO  
KA  
KK  
X

Hohlmeißelzangen  
 Bone Rongeurs  
 Pinzas-gubias  
 Pincès-gouges  
 Pinze-sgorbie



**MARQUARDT**  
 KA 821/20  
 20,0 cm/8"



**MAYFIELD**  
 KA 823/17  
 17,0 cm/6<sup>3</sup>/<sub>4</sub>"



**BEYER**  
 KA 830/18  
 18,0 cm/7"



**ZAUFAL-JANSEN**  
 KA 835/18  
 18,0 cm/7"



**RUSKIN**  
 KA 836/18  
 18,0 cm/7"

Hohlmeißelzangen  
 Bone Rongeurs  
 Pinzas-gubias  
 Pincès-gouges  
 Pinze-sgorbie

AA  
 AB  
 AC  
 AD  
 AE  
 AF  
 AG  
 AH  
 AI  
 AJ  
 AK  
 AL  
 AO  
**KA**  
 KK  
 X

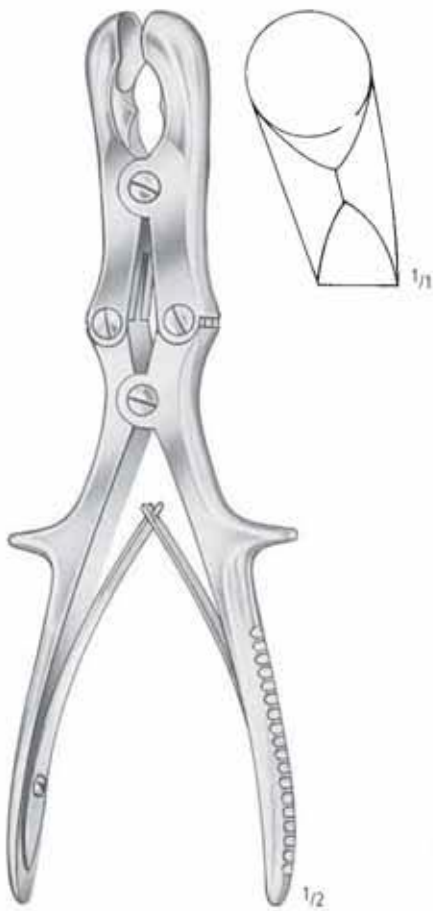

**SEMB**  
 KA 838/22  
 22,5 cm/9"



**STILLE**  
 KA 840/23  
 23,0 cm/9"



**STILLE-RUSKIN**  
 KA 841/23  
 23,0 cm/9"

Hohlmeißelzangen  
 Bone Rongeurs  
 Pinzas-gubias  
 Pincès-gouges  
 Pinze-sgorbie



**ROETTGEN-RUSKIN**  
 KA 845/24  
 24,0 cm/9<sup>1</sup>/<sub>2</sub>"



**LEKSELL-STILLE**  
 24,0 cm/9<sup>1</sup>/<sub>2</sub>"

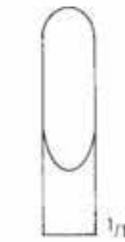

KA 848/01  
 8 mm

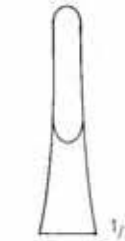

KA 848/02  
 4 mm



**STILLE-LUER**  
 22,0 cm/8<sup>3</sup>/<sub>4</sub>"

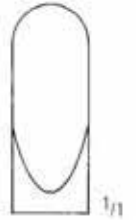

KA 852/22

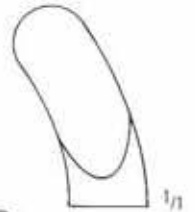

KA 853/22



Hohlmeißelzangen  
 Bone Rongeurs  
 Pinzas-gubias  
 Pincas-gouges  
 Pinze-sgorbie

AA  
 AB  
 AC  
 AD  
 AE  
 AF  
 AG  
 AH  
 AI  
 AJ  
 AK  
 AL  
 AM  
 AN  
 AO  
 AP  
 AQ  
 AR  
 AS  
 AT  
 AU  
 AV  
 AW  
 AX  
 AY  
 AZ



**SAUERBRUCH**  
 30,0 cm/12"



**FRYKHOLM**  
 KA 859/23  
 23,0 cm/9"

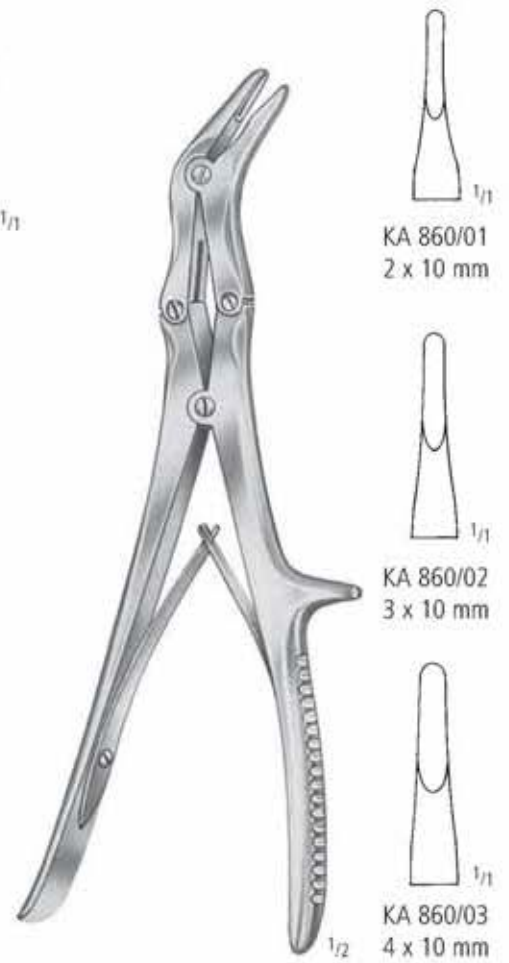

**ECHLIN**  
 23,0 cm/9"





Hohlmeißelzangen  
 Bone Rongeurs  
 Pinzas-gubias  
 Pince-gouges  
 Pinze-sgorbie



**RUSKIN**  
 KA 862/23  
 23,0 cm/9"



**SMITH-PETERSON**  
 24,0 cm/9 1/2"



3,0 mm  
 KA 863/03

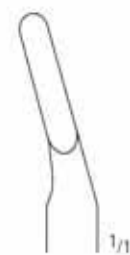

4,0 mm  
 KA 863/04



5,0 mm  
 KA 863/05



3,0 mm  
 KA 863/13



4,0 mm  
 KA 863/14



5,0 mm  
 KA 863/15

Knochensplitterzangen  
 Bone Cutting Forceps  
 Pinzas cortantes para huesos  
 Pinces coupantes à os  
 Cesioie per ossa

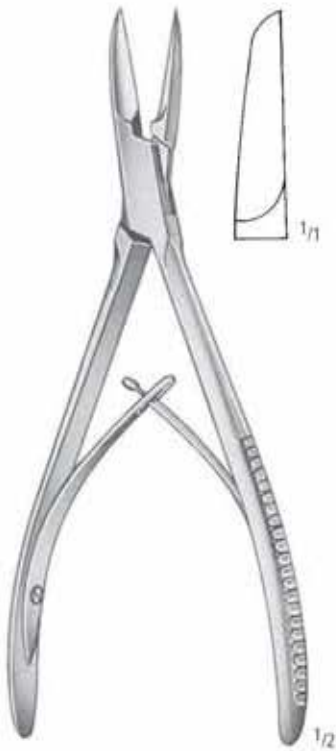

**COTTLE KAZANJIAN**  
 KA 870/19  
 19,0 cm/7 1/2"



**CLEVELAND-GARDNER**  
 KA 872/16  
 18,0 cm/6 1/4"



**MARKWALDER**  
 KA 874/20  
 20,0 cm/8"

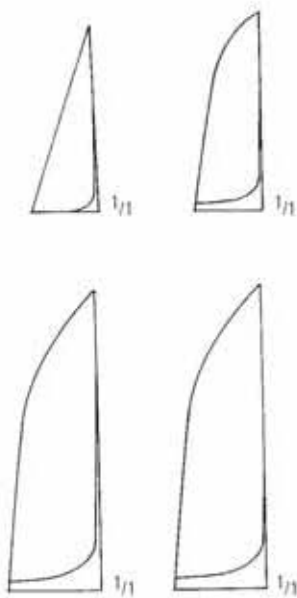

KA 880/14  
 KA 880/17  
 KA 880/19  
 KA 880/22



**LISTON**  
 14,0 cm/5 1/2"  
 17,0 cm/6 3/4"  
 19,0 cm/7 1/2"  
 22,0 cm/8 3/4"

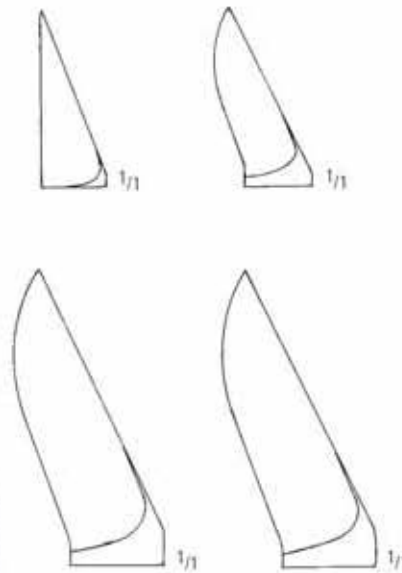

KA 881/14  
 KA 881/17  
 KA 881/19  
 KA 881/22



**LITTAUER-LISTON**  
 KA 882/15  
 15,0 cm/6"

AA  
 AB  
 AC  
 AD  
 AE  
 AF  
 AK  
 AL  
 AO  
 KA  
 KK  
 X



Knochensplitterzangen  
 Bone Cutting Forceps  
 Pinzas cortantes para huesos  
 Pincès coupantes à os  
 Cesioie per ossa

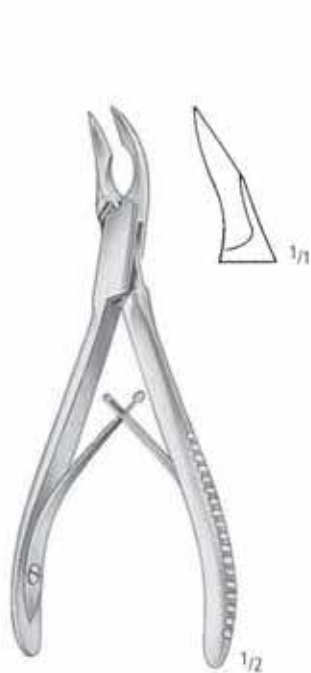

**CLEVELAND**  
 KA 884/15  
 15,0 cm/6"



**CLEVELAND**  
 KA 884/17  
 17,0 cm/6<sup>3</sup>/<sub>4</sub>"



KA 885/12  
 12,0 cm/4<sup>3</sup>/<sub>4</sub>"

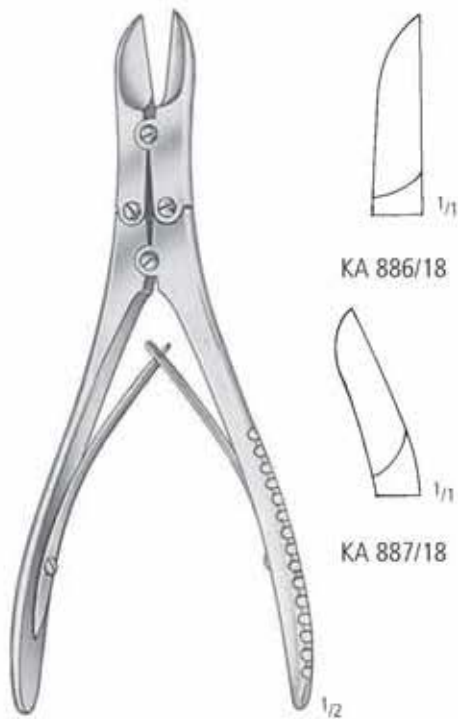

**RUSKIN-LISTON**  
 18,5 cm/7<sup>1</sup>/<sub>4</sub>"



**MC INDOE**  
 KA 888/17  
 17,5 cm/7"



**WALTON-LISTON**  
 KA 889/01  
 15,0 cm/6"

Knochensplitterzangen  
 Bone Cutting Forceps  
 Pinzas cortantes para huesos  
 Pinces coupantes à os  
 Cesioie per ossa

AA  
 AB  
 AC  
 AD  
 AE  
 AF  
 AK  
 AL  
 AO  
 KA  
 KK  
 X



KA 890/00



KA 890/30

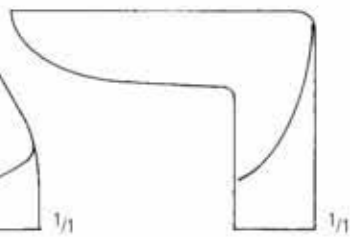

KA 890/90



**LISTON-KEY (TUDOR-EDWARDS)**  
 KA 892/27  
 27,0 cm/10<sup>1</sup>/<sub>2</sub>"

**STILLE-LISTON**  
 27,0 cm/10<sup>1</sup>/<sub>2</sub>"

Knochensplitterzangen  
 Bone Cutting Forceps  
 Pinzas cortantes para huesos  
 Pinces coupantes à os  
 Cesioie per ossa



**SEMB**  
 KA 893/24  
 24,0 cm/9<sup>1</sup>/<sub>2</sub>"

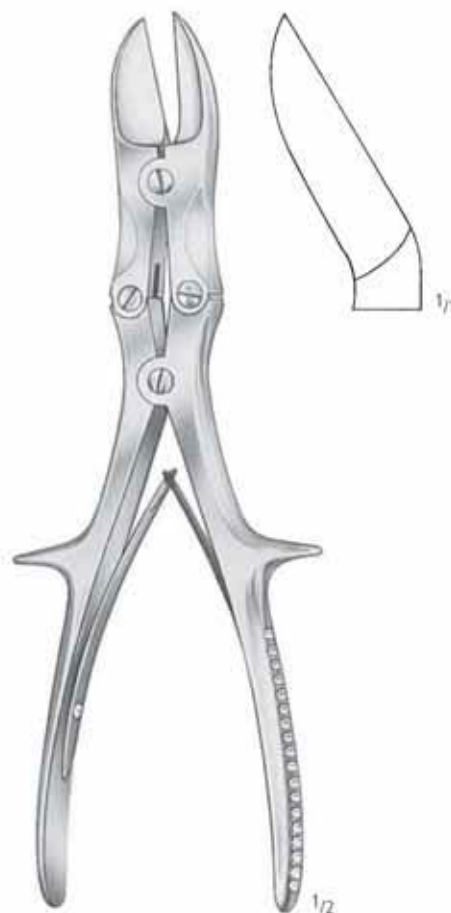

**LISTON**  
 KA 894/23  
 23,5 cm/9<sup>1</sup>/<sub>4</sub>"



HERZ/THORAX  
CARDIOVASCULAR  
CARDIOVASCULAR  
CARDIOVASCULAIRE  
CARDIOVASCOLARE

KK

nopa<sup>®</sup> instruments

Rippen-Instrumente	Seite	235-238
Rib Instruments	Page	235-238
Instrumentos costales	Página	235-238
Instruments des côtes	Page	235-238
Strumenti per costali	Pagina	235-238
Rippensperrer	Seite	239-250
Rib Spreaders	Page	239-250
Separadores costales	Página	239-250
Ecarteurs des côtes	Page	239-250
Divaricatori costali	Pagina	239-250
Clips, Bulldogklemmen	Seite	257-263
Clips, Bulldog Clamps	Page	257-263
Clips, Clamps Bulldog	Página	257-263
Clips, Clamps Bulldog	Page	257-263
Clips, Pinze Bulldog	Pagina	257-263
Atrauma-Klemmen	Seite	260-296
Atrauma Forceps	Page	260-296
Pinzas Atrauma	Página	260-296
Pinces atraumatiques	Page	260-296
Pinze Atrauma	Pagina	260-296







Rippen-Raspatorien  
 Costal periosteotomes  
 Periostótomos para costillas  
 Rugines raspatoires  
 Periostotomi costali

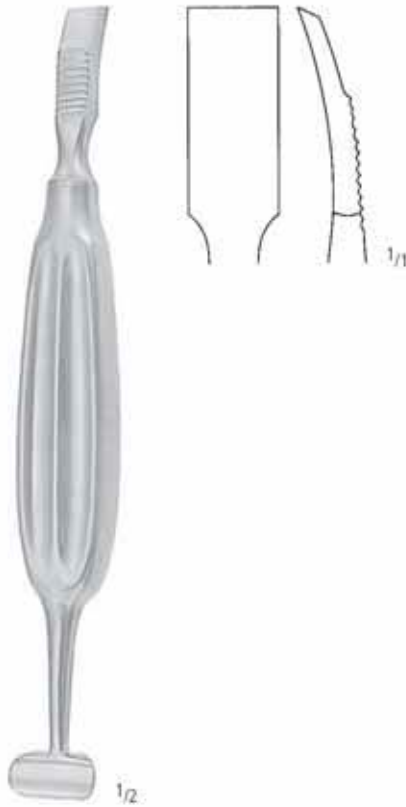

**ALEXANDER**  
 KK 001/20  
 20,0 cm/8"

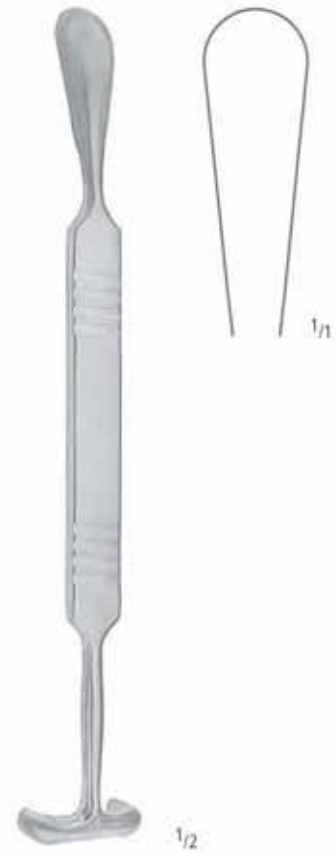

**MATSON**  
 KK 002/22  
 22,0 cm/8<sup>3</sup>/<sub>4</sub>"



**DOYEN**  
 KK 004/01  
 17,0 cm/6<sup>3</sup>/<sub>4</sub>"



**DOYEN**  
 KK 004/02  
 17,0 cm/6<sup>3</sup>/<sub>4</sub>"



**DOYEN**  
 KK 004/03  
 18,0 cm/7"



**DOYEN**  
 KK 004/04  
 18,0 cm/7"

AA  
 AB  
 AC  
 AD  
 AE  
 AF  
 AK  
 AL  
 AO  
 KA  
 KK  
 X

Rippen-Raspatorien  
 Costal periosteotomes  
 Periostótomos para costillas  
 Rugines raspatoires  
 Periostotomi costali



**LAMBOTTE**  
 21,0 cm/8<sup>1</sup>/<sub>4</sub>"



**SEMB**

Knochen- und Rippenscheren  
 Bone and Rib Shears  
 Cizallas para huesos, Costotomos  
 Cisailles pour os, Costotomes  
 Pinze per ossa e costole, Costotomi



KK 010/23  
 23,0 cm/9"



KK 011/22  
 22,0 cm/8<sup>3</sup>/<sub>4</sub>"



**GLUCK**  
 KK 013/22  
 22,0 cm/8<sup>3</sup>/<sub>4</sub>"



**BETHUNE**  
 KK 018/34  
 34,0 cm/13<sup>1</sup>/<sub>2</sub>"



**SAUERBRUCH**  
 KK 019/26  
 26,0 cm/10<sup>1</sup>/<sub>4</sub>"



**CORYLLOS**  
 KK 021/35  
 35,0 cm/13<sup>3</sup>/<sub>4</sub>"



KK 023/35  
 35,0 cm/13<sup>3</sup>/<sub>4</sub>"

AA  
 AB  
 AC  
 AD  
 AE  
 AF  
 AG  
 AH  
 AI  
 AJ  
 AK  
 AL  
 AM  
 AN  
 AO  
 AP  
 AQ  
 AR  
 AS  
 AT  
 AU  
 AV  
 AW  
 AX  
 AY  
 AZ

KK

Knochen- und Rippenscheren  
 Bone and Rib Shears  
 Cizallas para huesos, Costotomos  
 Cisailles pour os, Costotomes  
 Pinze per ossa e costole, Costotomi



**GIERTZ-STILLE**  
 KK 024/27  
 27,0 cm/10 1/2"



**BRUNNER**



KK 027/32  
 32,0 cm/12 1/2"



KK 029/32  
 32,0 cm/12 1/2"



**LEBSCHE**  
 KK 040/25  
 25,0 cm/10"

Rippensperrer  
 Rib Spreaders  
 Separadores costales  
 Ecarteurs des côtes  
 Divaricatori costali



B      H      C      **I.M.A. MAMMARIA RETRACTOR**  
 40 mm    150 mm    110 mm    KK 056/00



B      H      C      **HAIGHT**  
 30 mm    30 mm    90 mm    KK 080/00

AA  
 AB  
 AC  
 AD  
 AE  
 AF  
 AK  
 AL  
 AO  
 KA  
 KK  
 X



Rippensperrer  
 Rib Spreaders  
 Separadores costales  
 Ecarteurs des côtes  
 Divaricator costali



B 45 mm H 45 mm C 160 mm **TUFFIER**  
 KK 084/16

B 44 mm H 48 mm C 178 mm **BADGLEY**  
 KK 086/18



B 20 mm H 25 mm C 105 mm **HERTZLER**  
 KK 088/10

Rippensperrer  
 Rib Spreaders  
 Separadores costales  
 Ecarteurs des côtes  
 Divaricatori costali



B	H	C	<b>FINOCCHIETTO-BABY</b>
14 mm	15 mm	75 mm	KK 090/07



B	H	C	<b>FINOCCHIETTO</b>
30 mm	45 mm	150 mm	KK 092/01
46 mm	62 mm	190 mm	KK 092/02
80 mm	65 mm	190 mm	KK 092/03

AA  
 AB  
 AC  
 AD  
 AE  
 AF  
 AK  
 AL  
 AO  
 KA  
 KK  
 X

Rippen-sperr  
Rib Spreaders  
Separadores costales  
Ecarteurs des côtes  
Divaricatori costali

# ALUMINIUM



B	H	C	<b>ANKENEY</b>
19 mm	25 mm	127 mm	KK 093/04

Rippensperer  
Rib Spreaders  
Separadores costales  
Ecarteurs des côtes  
Divaricatori costali



B	H	C	<b>ANKENY</b>
35 mm	32 mm	178 mm	KK 093/06

AA  
AB  
AC  
AD  
AE  
AF  
AK  
AL  
AO  
KA  
KK  
X



Rippensperrer  
Rib Spreaders  
Separadores costales  
Ecarteurs des côtes  
Divaricatori costali

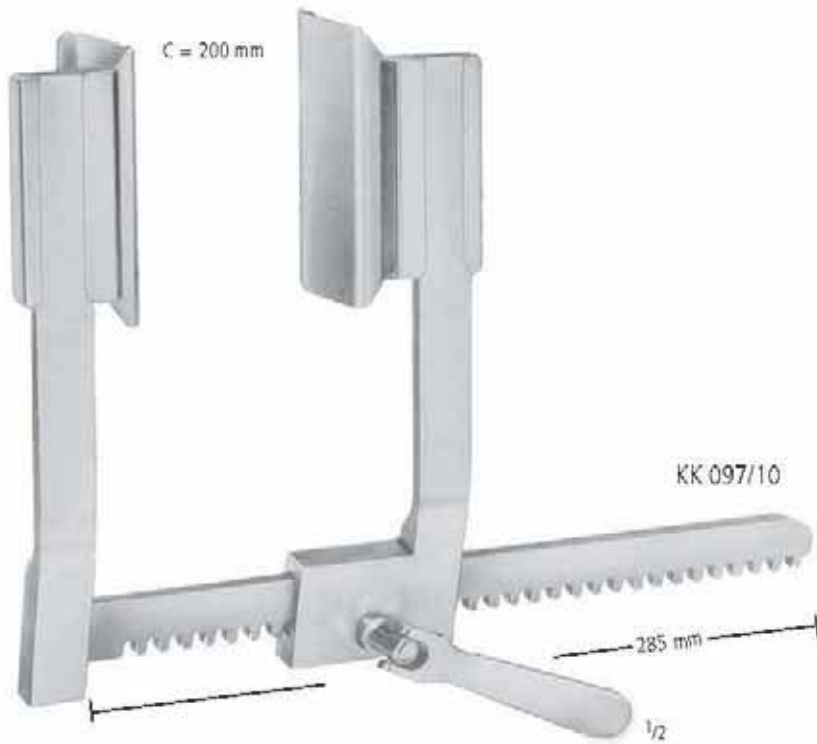

**DE BAKEY**

- KK 097/00 = 1 x KK 097/10  
+ 2 x KK 097/01  
+ 2 x KK 097/02  
+ 2 x KK 097/03

**Sternotomy**



KK 097/05  
50 x 66 mm



KK 097/01  
60 x 60 mm



KK 097/02  
50 x 80 mm



KK 097/03  
40 x 100 mm



KK 097/04  
80 x 60 mm

AA  
AB  
AC  
AD  
AE  
AF  
AK  
AL  
AO  
KA  
KK  
X



Rippensperrer  
 Rib Spreaders  
 Separadores costales  
 Ecarteurs des côtes  
 Divaricator costali

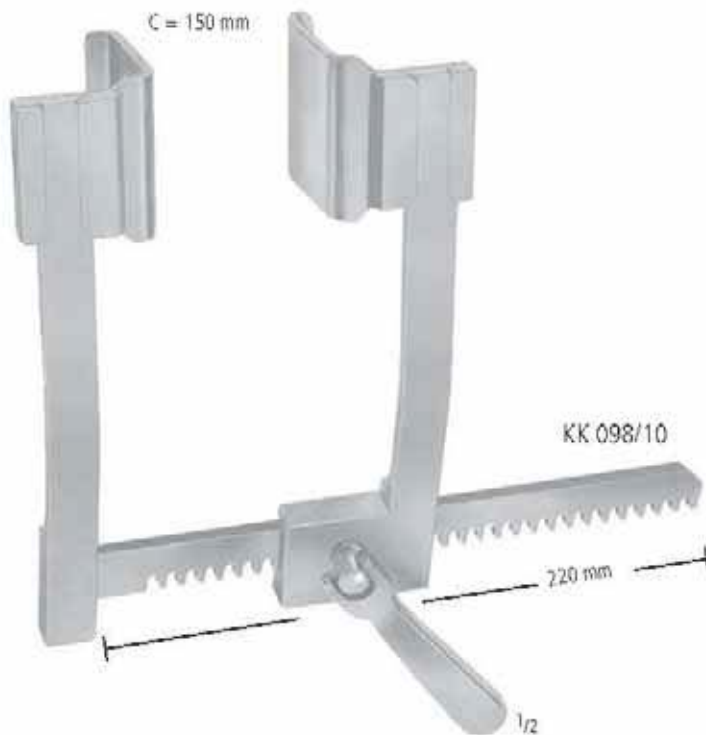

KK 098/01  
 30 x 30 mm



KK 098/02  
 40 x 40 mm



KK 098/03  
 50 x 50 mm

**DE BAKY**

- KK 098/00 = 1 x KK 098/10
- + 2 x KK 098/01
- + 2 x KK 098/02
- + 2 x KK 098/03

Rippensperrer  
 Rib Spreaders  
 Separadores costales  
 Ecarteurs des côtes  
 Divaricatori costali

**MORSE FAVALORO**

B	H	C	
19 mm	29 mm	200 mm	KK 099/01
12 mm	20 mm	200 mm	KK 099/02

AA

AB

AC

AD

AE

AF

AK

AL

AO

KA

KK

X

Rippensperrer  
 Rib Spreaders  
 Separadores costales  
 Ecarteurs des côtes  
 Divaricatori costali

# ALUMINIUM



## FINOCCHIETTO

B	H	C	
40 mm	45 mm	135 mm	KK 100/01
52 mm	62 mm	175 mm	KK 100/02
84 mm	65 mm	175 mm	KK 100/03
31 mm	31 mm	100 mm	KK 102/30
15 mm	15 mm	75 mm	KK 104/00



Rippensperrer  
Rib Spreaders  
Separadores costales  
Ecarteurs des côtes  
Divaricatori costali

# ALUMINIUM

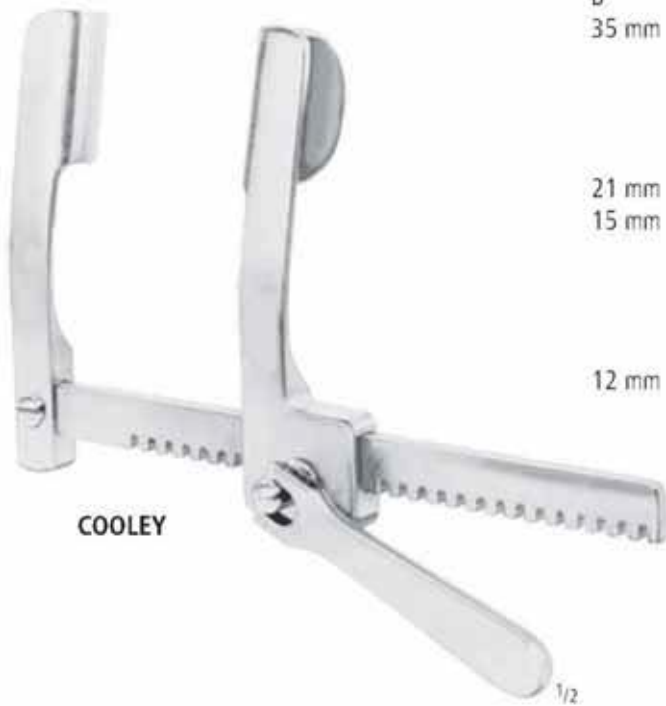

**COOLEY**

B	H	C	
35 mm	50 mm	200 mm	KK 106/01

21 mm	44 mm	150 mm	KK 106/02
15 mm	30 mm	140 mm	KK 106/03

12 mm	16 mm	95 mm	KK 106/04
-------	-------	-------	-----------



**CASTANEDA**

B	H	C	
15 mm	60 mm	120 mm	KK 110/01

12 mm	45 mm	70 mm	KK 110/02
-------	-------	-------	-----------

10,5 mm	32 mm	65 mm	KK 110/03
---------	-------	-------	-----------



AA  
AB  
AC  
AD  
AE  
AF  
AK  
AL  
AO  
KA  
KK  
X

Rippensperrer  
 Rib Spreaders  
 Separadores costales  
 Ecarteurs des côtes  
 Divaricatori costali

# ALUMINIUM



mit 2 Paar Valven  
 with 2 pairs of blades  
 con 2 pares de valvas  
 avec 2 paires des valves  
 con 2 pala di valve

**BURFORD**

B	H	C	
65 mm	62 mm		
47 mm	62 mm	200 mm	KK 120/01
65 mm	62 mm		
47 mm	62 mm	250 mm	KK 120/02
65 mm	62 mm		
47 mm	62 mm	300 mm	KK 120/03

48 mm	42 mm		
34 mm	42 mm	135 mm	KK 120/04



Spatel  
Spatulas  
Espátulas  
Spatules  
Spatole



KK 150/18  
18,5 cm/7<sup>1</sup>/<sub>4</sub>"

KK 150/21  
21,5 cm/8<sup>1</sup>/<sub>2</sub>"

KK 152/23  
23,0 cm/9"



**DAVIS**  
KK 153/24  
24,5 cm/9<sup>3</sup>/<sub>4</sub>"

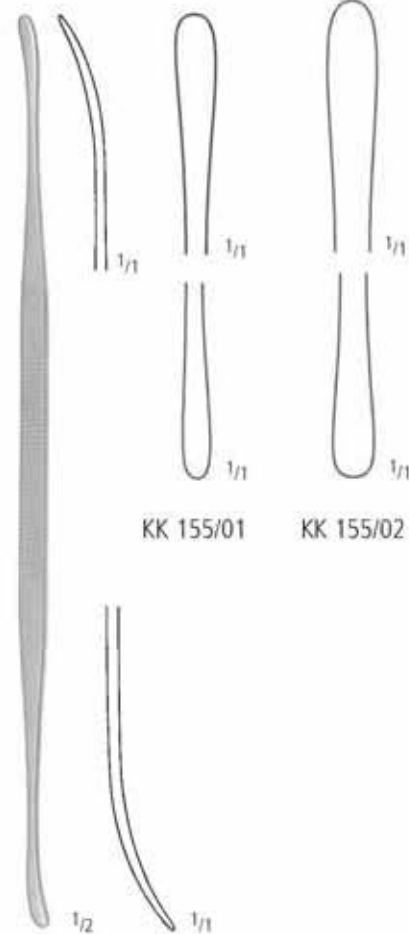

**TÖNNIS**  
24,0 cm/9<sup>1</sup>/<sub>2</sub>"

KK 155/01

KK 155/02



**SCHMID**



KK 156/01  
14,0 cm/5<sup>1</sup>/<sub>2</sub>"



KK 156/02  
23,5 cm/9<sup>1</sup>/<sub>4</sub>"



**PENFIELD**  
KS 638/01  
17,5 cm/7"

AA  
AB  
AC  
AD  
AE  
AF  
AK  
AL  
AO  
KA  
X  
KK



Feine Wundhaken  
 Delicate Hooks  
 Ganchos  
 Crochets très fins  
 Divaricatori sottili

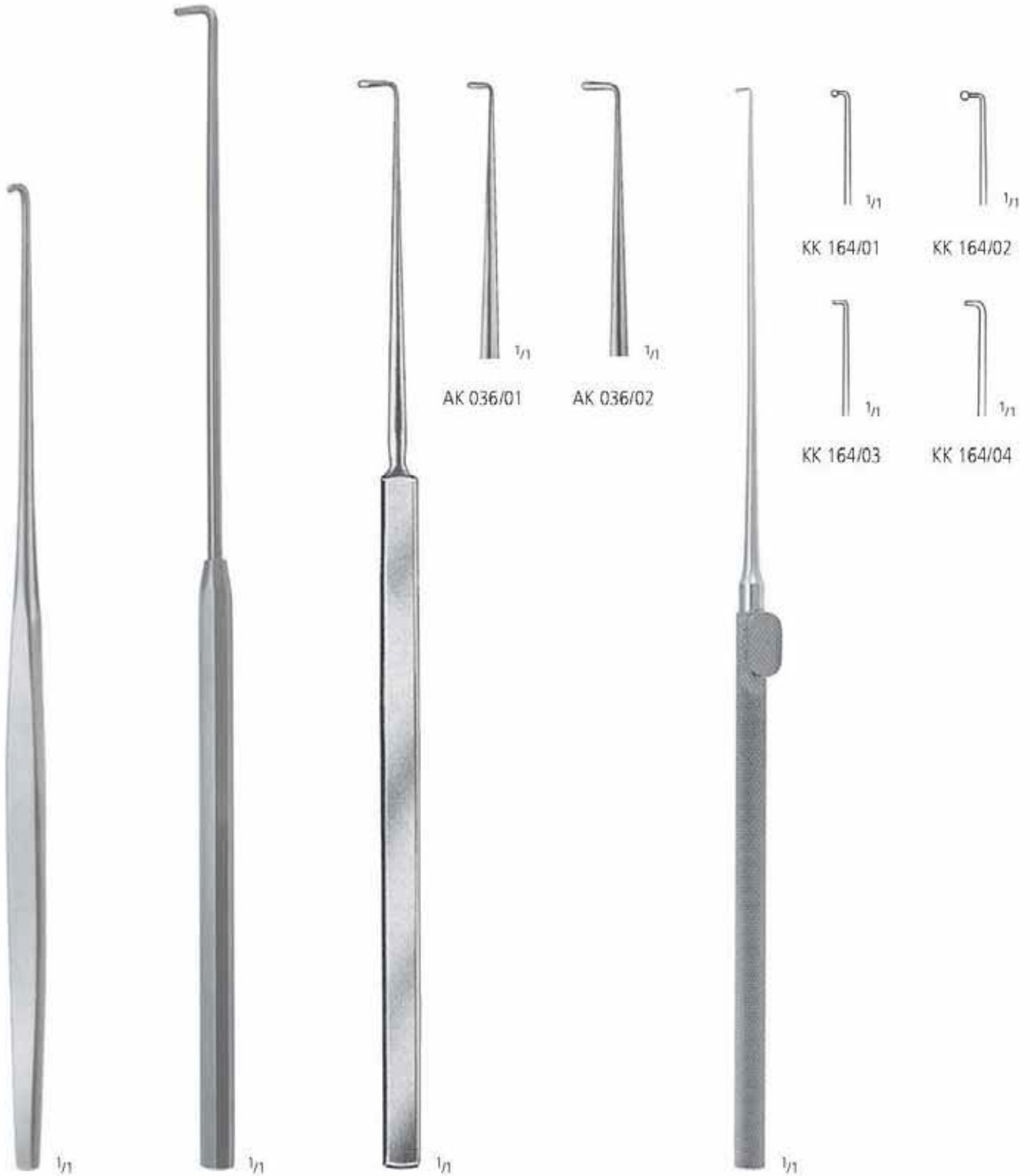

**BROM**  
 KK 160/17  
 17,0 cm / 6 3/4"

**CRILE**  
 KK 162/20  
 20,0 cm / 8"

**CUSHING**  
 19,0 cm / 7 1/2"

**KRAYENBÜHL**  
 18,5 cm / 7 1/4"

Feine Wundhaken  
 Delicate Hooks  
 Ganchos  
 Crochets très fins  
 Divaricatori sottili

AA  
 AB  
 AC  
 AD  
 AE  
 AF  
 AK  
 AL  
 AO  
 KA  
**KK**  
 X



**BIEMER**  
 KK 165/16  
 16,0 cm/6<sup>1</sup>/<sub>4</sub>"



**FISCH**  
 18,5 cm/7<sup>1</sup>/<sub>4</sub>"



KK 166/02



**GILLIES**  
 18,0 cm/7"



AK 020/01



AK 020/02



**KILNER**  
 AK 022/15  
 15,0 cm/6"

Rippenkontraktoren  
 Rib contractors  
 Aproximadores para costillas  
 Rapprocheurs des côtes  
 Approssimatori costali



**SELLORS**  
 KK 170/19  
 19,0 cm/7 1/2"



**BAILEY-BABY**  
 KK 172/14  
 14,0 cm/5 1/2"



**BAILEY**  
 KK 174/16  
 16,0 cm/6 1/4"



**BAILEY-GIBBON**  
 KK 176/16  
 16,0 cm/6 1/4"

Lungenspatel  
 Lung Spatulas  
 Espátulas pulmonares  
 Spatules pulmonaires  
 Spatole per polmone

AA  
 AB  
 AC  
 AD  
 AE  
 AF  
 AK  
 AL  
 AO  
 KA  
**KK**  
 X



**ALLISON**

KK 180/26	KK 180/32
26,0 cm/10 <sup>1</sup> / <sub>4</sub> "	32,0 cm/12 <sup>1</sup> / <sub>2</sub> "

Atriumhaken  
Atrium retractor  
Separadores auriculares  
Ecarteurs à atrium  
Divaricator atriali

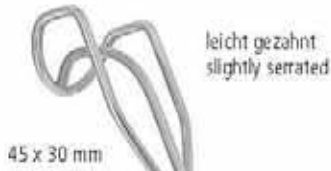

**COOLEY-STRUCK**  
KK 188/01  
24,0 cm/9 1/2"

**COOLEY-STRUCK**  
KK 188/02  
24,0 cm/9 1/2"

**COOLEY**  
KK 190/01  
24,5 cm/9 3/4"

**COOLEY**  
KK 190/02  
24,5 cm/9 3/4"

**COOLEY**  
KK 190/03  
25,5 cm/10"

Clips  
Clips  
Clips  
Clips  
Clips

AA  
AB  
AC  
AD  
AE  
AF  
AK  
AL  
AO  
KA  
KK  
X

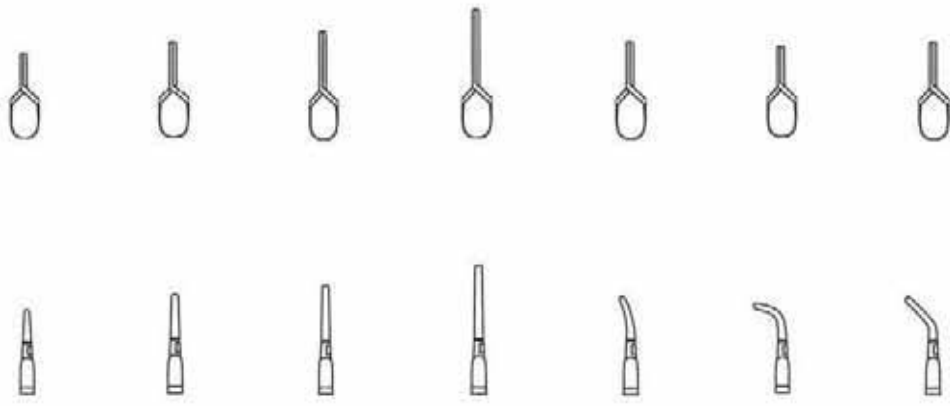

L	KK 300/01	KK 300/02	KK 300/03	KK 300/04	KK 300/05	KK 300/06	KK 300/07	F
W	4 mm	6 mm	8 mm	10 mm	6 mm	6 mm	6 mm	Schließkraft
F	0,75 mm	1 mm	2 mm	2 mm	1 mm	1 mm	1 mm	Closing force
	125 gr	100 gr	85 gr	60 gr	85 gr	85 gr	85 gr	Presión
								Pressione

F  
Schließkraft  
Closing force  
Presión  
Pressione



KK 302/14  
14,0 cm/5 1/2"



KK 303/18  
18,0 cm/7"



Clips  
Clips  
Clips  
Clips  
Clips



**BIEMER**



KK 306/01

L 6 mm  
W 4 mm  
F 30-40 gr

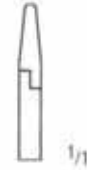

KK 306/02

L 9 mm  
W 5 mm  
F 30-40 gr



KK 306/03

L 9 mm  
W 5 mm  
F 20-25 gr



KK 308/01  
14,5 cm/5<sup>3</sup>/<sub>4</sub>"



KK 308/02  
14,5 cm/5<sup>3</sup>/<sub>4</sub>"

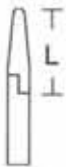

F Schließkraft  
Closing force  
Presión  
Pression  
Pressione

W Maulöffnung  
Opening  
Abertura  
Overture  
Apertura

**MEHDORN**



KK 310/01

L 4 mm  
W 1,0 mm  
F 10-15 gr



KK 310/02

L 4 mm  
W 1,4 mm  
F 15-20 gr



KK 310/03

L 6 mm  
W 1,0 mm  
F 10-15 gr



KK 310/04

L 6 mm  
W 1,4 mm  
F 15-20 gr

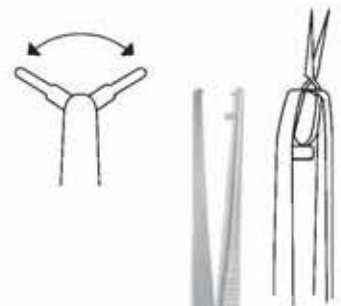

KK 312/15  
15,0 cm/6"

Clips  
Clips  
Clips  
Clips  
Clips



**MÜLLER**

F = 50gr  
F = 80gr



KK 314/50  
KK 314/80



KK 315/50  
KK 315/80



KK 316/50  
KK 316/80

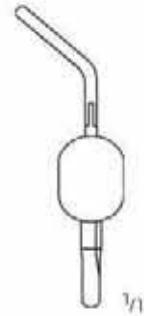

KK 317/50  
KK 317/80

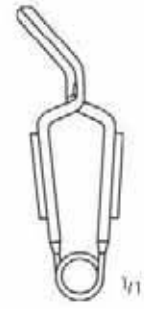

KK 318/50  
KK 318/80

F  
Schließkraft  
Closing force  
Presión  
Pression  
Pressione



**DE BAKEY-HESS**  
KK 320/01



**DE BAKEY-HESS**  
KK 320/02

AA  
AB  
AC  
AD  
AE  
AF  
AK  
AL  
AO  
KA  
KK  
X

Atrauma Bulldogklemmen  
 Atrauma Bulldog Clamps  
 Atrauma Clamps Bulldog  
 Clamps Atrauma Bulldog  
 Pinze Atrauma Bulldog



DE BAKEY



DE BAKEY



KK 350/07  
7,5 cm/3"



KK 350/08  
8,5 cm/3 1/2"



KK 350/10  
10,5 cm/4 1/4"



KK 350/12  
12,0 cm/4 3/4"



DE BAKEY



KK 351/07  
7,0 cm/2 3/4"



KK 351/08  
8,0 cm/3 1/4"



KK 351/10  
10,0 cm/4"



KK 351/12  
11,5 cm/4 1/2"



SANTULLI  
 KK 357/07  
 7,0 cm/2 3/4"

Atrauma Bulldogklemmen  
 Atrauma Bulldog Clamps  
 Atrauma Clamps Bulldog  
 Clamps Atrauma Bulldog  
 Pinze Atrauma Bulldog



DE BAKEY



GLOVER



KK 370/06  
 6,0 cm/2 1/2"



KK 370/07  
 7,5 cm/2 3/4"



KK 370/09  
 9,0 cm/3 1/2"



KK 370/11  
 11,0 cm/4 1/2"



GLOVER



KK 371/06  
 5,5 cm/2 1/4"



KK 371/07  
 6,5 cm/2 1/2"



KK 371/09  
 8,5 cm/3 1/3"



KK 371/11  
 10,5 cm/4 1/4"



GLOVER  
 KK 372/05  
 5,0 cm/2"

AA  
 AB  
 AC  
 AD  
 AE  
 AF  
 AG  
 AH  
 AI  
 AJ  
 AK  
 AL  
 AM  
 AN  
 AO  
 AP  
 AQ  
 AR  
 AS  
 AT  
 AU  
 AV  
 AW  
 AX  
 AY  
 AZ

KK

Atrauma Bulldogklemmen  
 Atrauma Bulldog Clamps  
 Atrauma Clamps Bulldog  
 Clamps Atrauma Bulldog  
 Pinze Atrauma Bulldog



**DE BAKEY**



**DE BAKEY-SATINSKY**  
 KK 373/07  
 7,0 cm/2¾"



**DE BAKEY-CAROTIS**  
 KK 373/09  
 9,0 cm/3½"



**DE BAKEY-SATINSKY**  
 KK 373/10  
 10,0 cm/4"

Atrauma Bulldogklemmen  
 Atrauma Bulldog Clamps  
 Atrauma Clamps Bulldog  
 Clamps Atrauma Bulldog  
 Pinze Atrauma Bulldog



DE BAKEY



GREGORY-SOFT



KK 375/01  
 9,0 cm/3 1/2"



KK 375/02  
 11,0 cm/4 1/2"



KK 375/03  
 11,0 cm/4 1/2"



KK 375/04  
 11,0 cm/4 1/2"

AA  
 AB  
 AC  
 AD  
 AE  
 AF  
 AK  
 AL  
 AO  
 KA  
 KK  
 X



Atrauma-Klemmen  
 Atrauma forceps  
 Pinzas Atrauma  
 Pincès atraumatiques  
 Pinze Atrauma



**DE BAKEY**

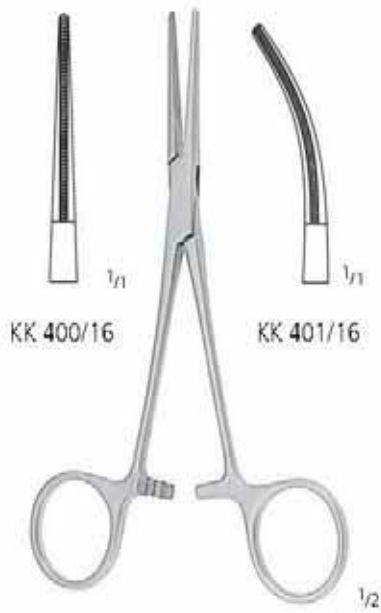

**DE BAKEY-RANKIN**  
 16,0 cm/6<sup>1</sup>/<sub>4</sub>"

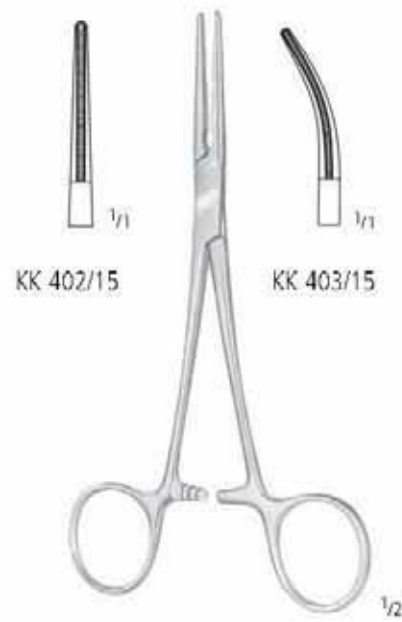

**DE BAKEY-MOSQUITO**  
 15,0 cm/6"

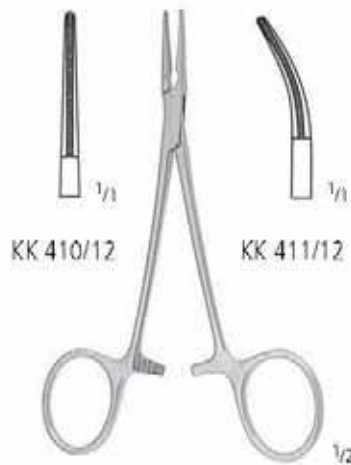

**DE BAKEY-MOSQUITO**  
 12,0 cm/4<sup>3</sup>/<sub>4</sub>"

Atrauma-Klemmen  
 Atrauma forceps  
 Pinzas Atrauma  
 Pincès atraumatiques  
 Pinze Atrauma



DE BAKEY



DE BAKEY-PEAN



KK 414/14  
 14,0 cm/5 1/2"

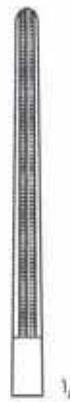

KK 414/16  
 16,0 cm/6 1/4"

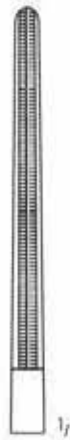

KK 414/18  
 18,0 cm/7"

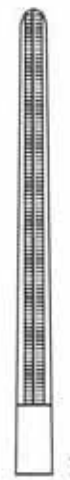

KK 414/20  
 20,0 cm/8"



KK 415/14  
 14,0 cm/5 1/2"



KK 415/16  
 16,0 cm/6 1/4"



KK 415/18  
 18,0 cm/7"

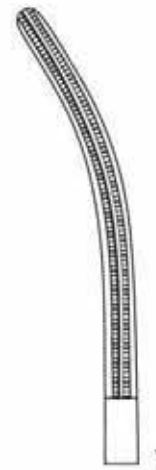

KK 415/20  
 20,0 cm/8"

AA  
 AB  
 AC  
 AD  
 AE  
 AF  
 AK  
 AL  
 AO  
 KA  
 KK  
 X

Atrauma-Klemmen  
 Atrauma Forceps  
 Pinzas Atrauma  
 Pincès atraumatiques  
 Pinze Atrauma



DE BAKEY



KK 440/21  
 21,0 cm/8<sup>1</sup>/<sub>4</sub>"

KK 440/22  
 22,0 cm/8<sup>3</sup>/<sub>4</sub>"

POTTS



KK 441/21  
 21,0 cm/8<sup>1</sup>/<sub>4</sub>"

KK 441/22  
 22,0 cm/8<sup>3</sup>/<sub>4</sub>"

POTTS

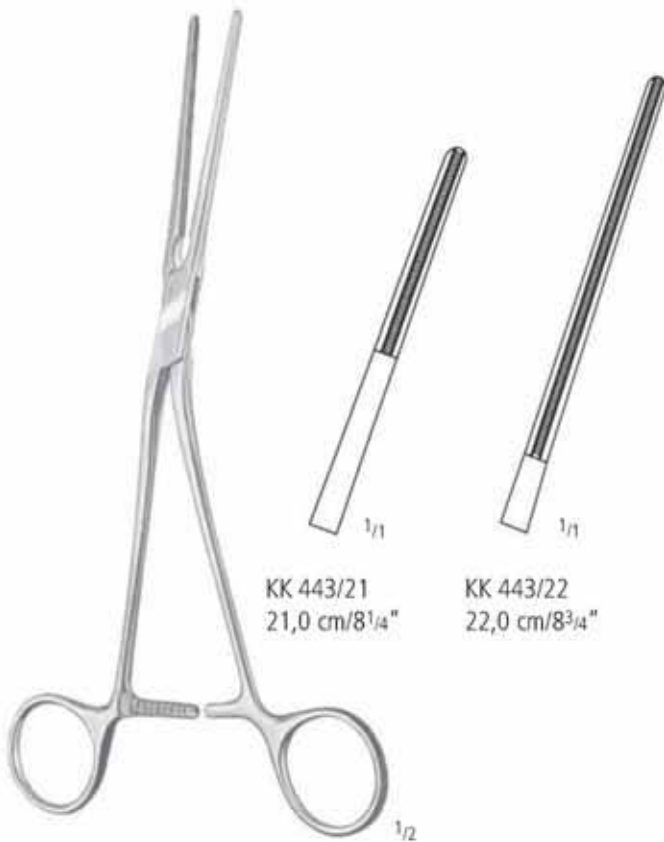

KK 443/21  
 21,0 cm/8<sup>1</sup>/<sub>4</sub>"

KK 443/22  
 22,0 cm/8<sup>3</sup>/<sub>4</sub>"

POTTS



KK 445/22

KK 447/22

POTTS  
 22,0 cm/8<sup>3</sup>/<sub>4</sub>"

Atrauma-Klemmen  
 Atrauma Forceps  
 Pinzas Atrauma  
 Pincès atraumatiques  
 Pinze Atrauma



DE BAKEY



DE BAKEY

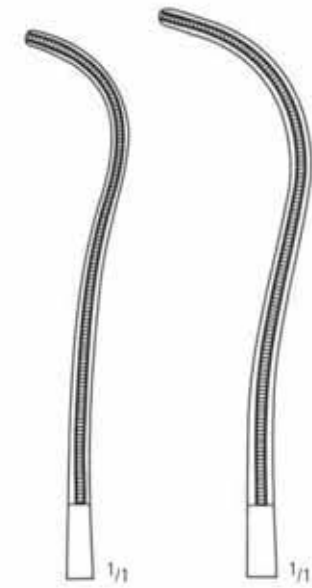

KK 449/19  
 19,0 cm/7 1/2"

KK 449/23  
 23,0 cm/9"



DE BAKEY  
 KK 451/16  
 16,0 cm/6 1/4"



DE BAKEY

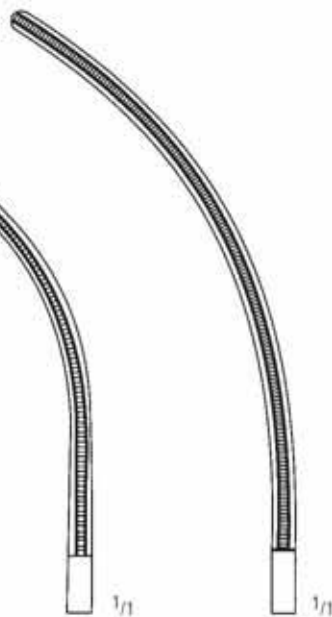

KK 453/19  
 19,0 cm/7 1/2"

KK 453/20  
 20,0 cm/8"



DE BAKEY  
 KK 455/20  
 20,0 cm/8"

AA  
 AB  
 AC  
 AD  
 AE  
 AF  
 AG  
 AH  
 AI  
 AJ  
 AK  
 AL  
 AM  
 AN  
 AO  
 AP  
 AQ  
 AR  
 AS  
 AT  
 AU  
 AV  
 AW  
 AX  
 AY  
 AZ

KK

Atrauma-Klemmen  
 Atrauma Forceps  
 Pinzas Atrauma  
 Pincès atraumatiques  
 Pinze Atrauma



**DE BAKAY**

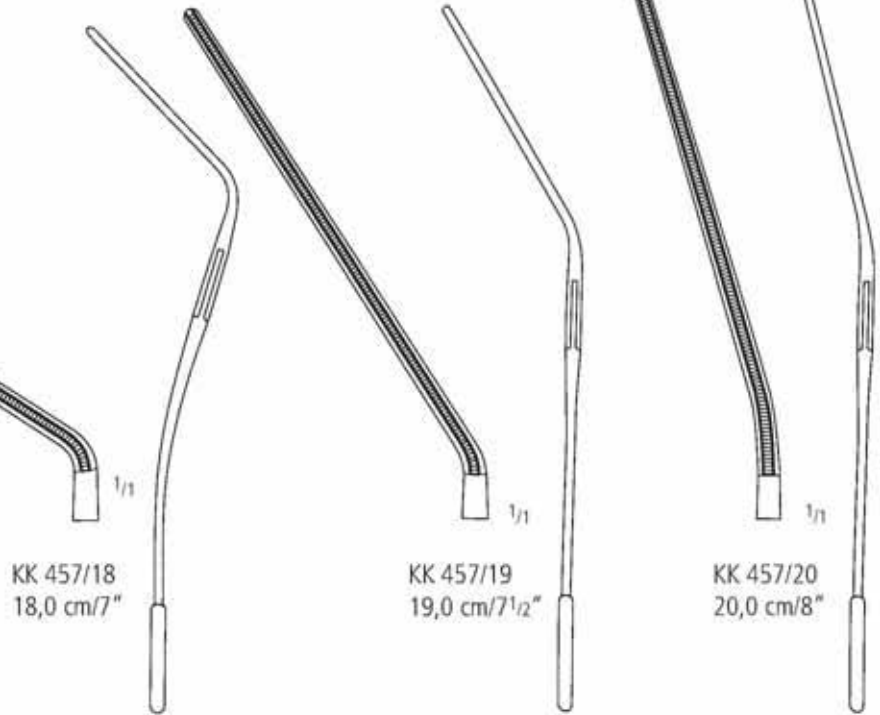

KK 457/18  
 18,0 cm/7"

KK 457/19  
 19,0 cm/7 1/2"

KK 457/20  
 20,0 cm/8"

**LELAND-JONES**

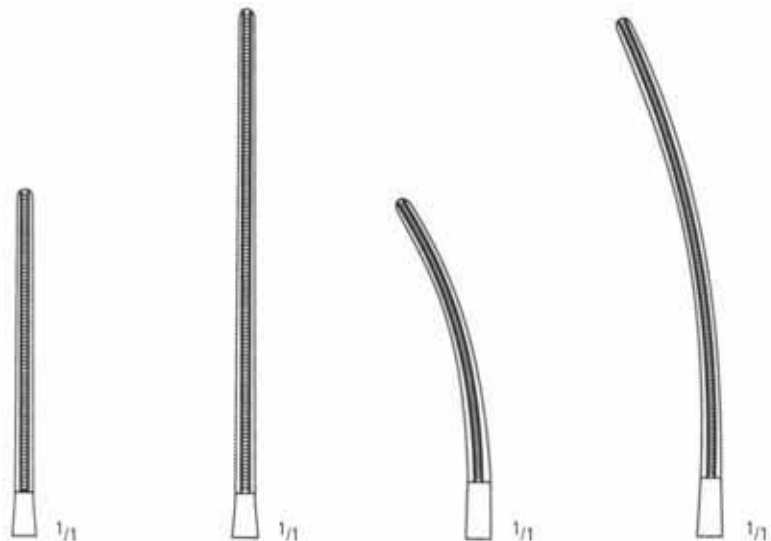

KK 460/15  
 15,0 cm/6"

KK 460/18  
 18,0 cm/7"

KK 461/15  
 15,0 cm/6"

KK 461/18  
 18,0 cm/7"

**BAINBRIDGE**



Atrauma-Klemmen  
 Atrauma Forceps  
 Pinzas Atrauma  
 Pincès atraumatiques  
 Pinze Atrauma



DE BAKEY



DE BAKEY

AA  
AB  
AC  
AD  
AE  
AF  
AK  
AL  
AO  
KA  
KK  
X



Atrauma-Klemmen  
 Atrauma Forceps  
 Pinzas Atrauma  
 Pincès atraumatiques  
 Pinze Atrauma



DE BAKEY



DE BAKEY

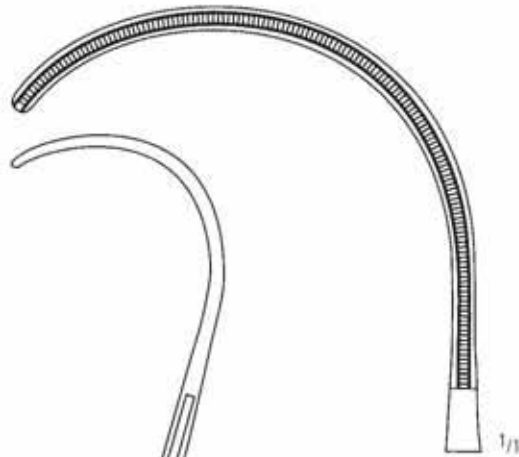

KK 473/25  
 25,0 cm/10"

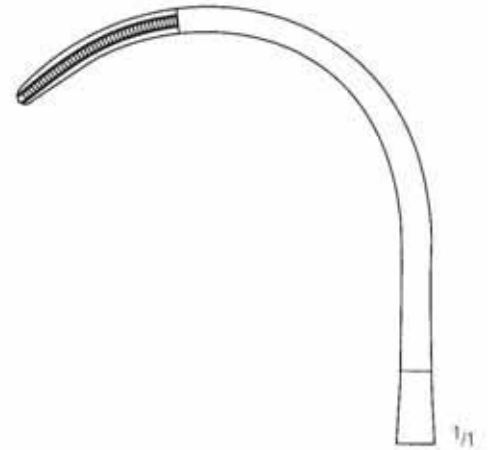

KK 475/26  
 26,0 cm/10<sup>1</sup>/<sub>2</sub>"



DE BAKEY



KK 477/24  
 24,0 cm/9<sup>1</sup>/<sub>2</sub>"

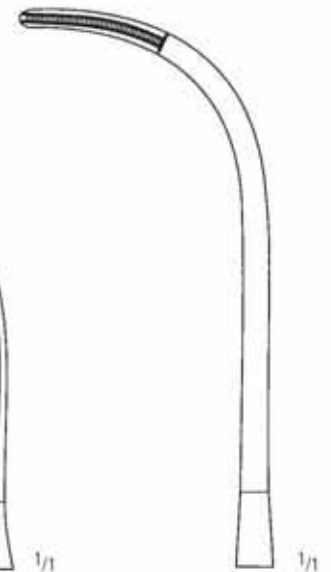

KK 479/24  
 24,0 cm/9<sup>1</sup>/<sub>2</sub>"

Atrauma-Klemmen  
 Atrauma Forceps  
 Pinzas Atrauma  
 Pincès atraumatiques  
 Pinze Atrauma



DE BAKEY



**DE BAKEY**  
 KK 481/30  
 30,0 cm/11<sup>3</sup>/<sub>4</sub>"

**DE BAKEY**  
 KK 483/28  
 28,0 cm/11"

AA  
 AB  
 AC  
 AD  
 AE  
 AF  
 AK  
 AL  
 AO  
 KA  
 KK  
 X

Atrauma-Klemmen  
 Atrauma Forceps  
 Pinzas Atrauma  
 Pincès atraumatiques  
 Pinze Atrauma



DE BAKEY



DE BAKEY



KK 486/21  
 21,0 cm/8 1/2"



KK 486/23  
 23,0 cm/9"



KK 486/27  
 27,0 cm/10 1/2"



KK 486/31  
 31,0 cm/12 1/2"



DE BAKEY

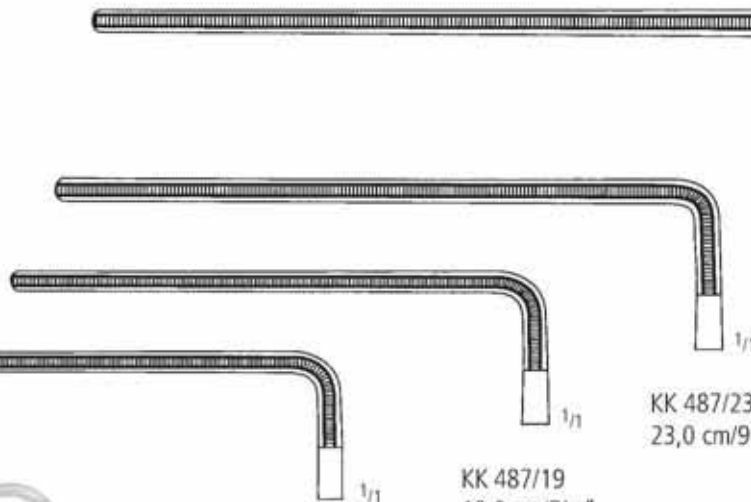

KK 487/18  
 18,0 cm/7"

KK 487/19  
 19,0 cm/7 1/2"

KK 487/23  
 23,0 cm/9"

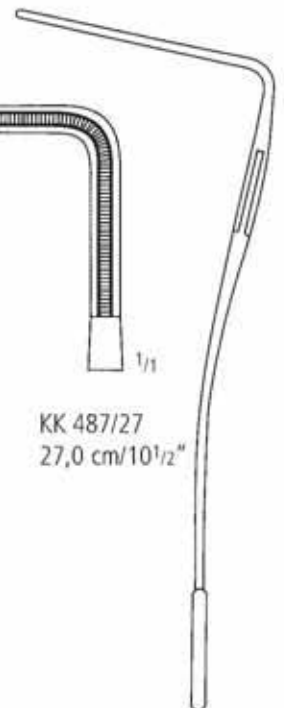

KK 487/27  
 27,0 cm/10 1/2"

Atrauma-Klemmen  
 Atrauma Forceps  
 Pinzas Atrauma  
 Pincès atraumatiques  
 Pinze Atrauma

**ATRAU<sup>®</sup>**  
 nopa<sup>®</sup>



DE BAKEY



DE BAKEY



KK 489/20  
 20,0 cm/8"

KK 489/21  
 21,0 cm/8<sup>1</sup>/<sub>4</sub>"

KK 489/25  
 25,0 cm/10"

KK 489/29  
 29,0 cm/11<sup>3</sup>/<sub>4</sub>"



DE BAKEY

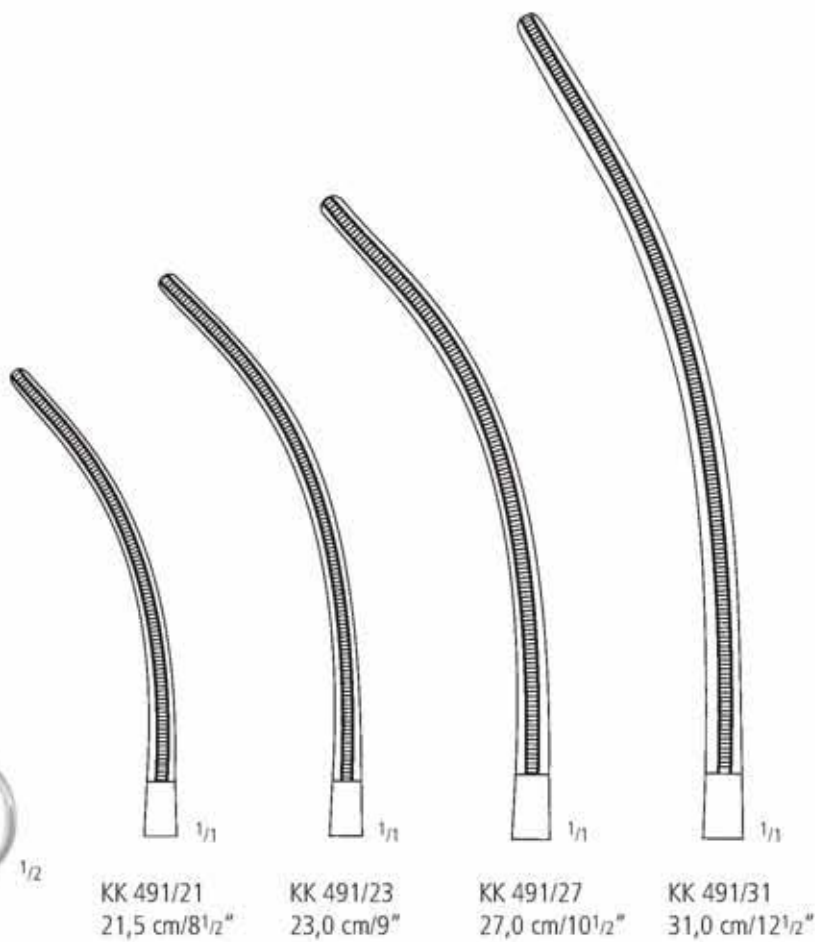

KK 491/21  
 21,5 cm/8<sup>1</sup>/<sub>2</sub>"

KK 491/23  
 23,0 cm/9"

KK 491/27  
 27,0 cm/10<sup>1</sup>/<sub>2</sub>"

KK 491/31  
 31,0 cm/12<sup>1</sup>/<sub>2</sub>"

AA  
 AB  
 AC  
 AD  
 AE  
 AF  
 AK  
 AL  
 AO  
 KA  
 KK  
 X

Atrauma-Klemmen  
 Atrauma Forceps  
 Pinzas Atrauma  
 Pincès atraumatiques  
 Pinze Atrauma



DE BAKEY

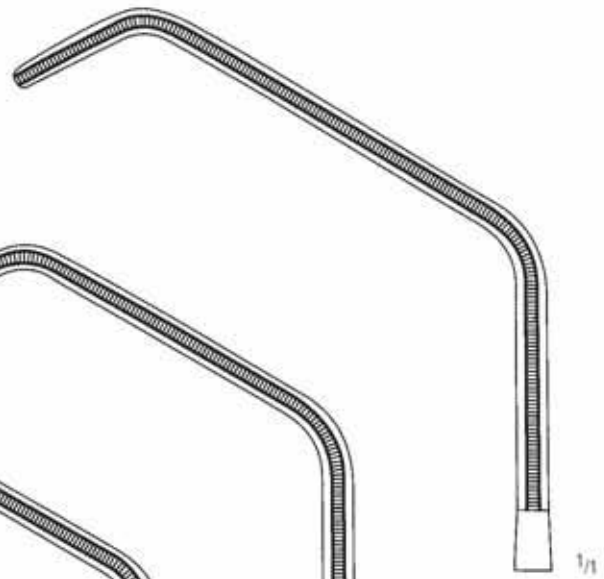

KK 493/27  
 27,5 cm/10<sup>3</sup>/<sub>4</sub>"

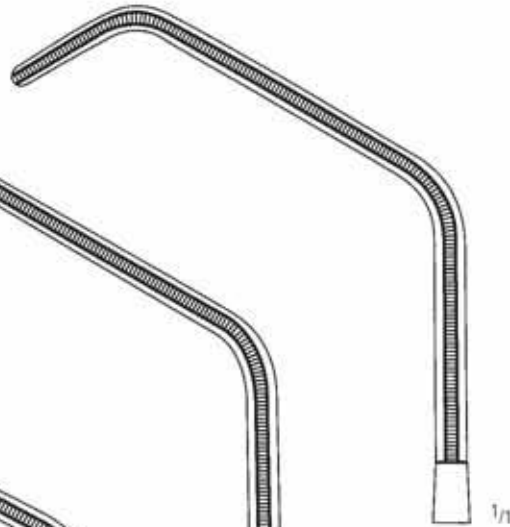

KK 493/26  
 26,5 cm/10<sup>1</sup>/<sub>2</sub>"

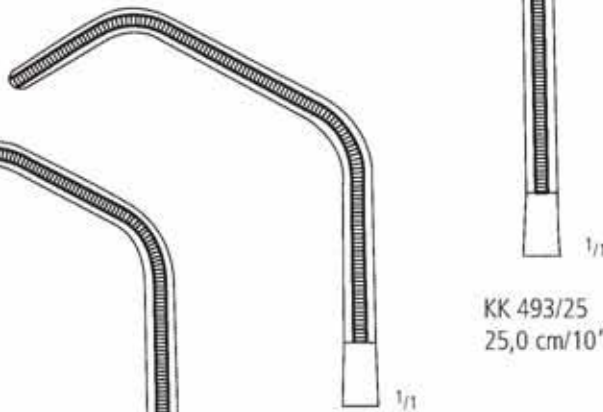

KK 493/25  
 25,0 cm/10"

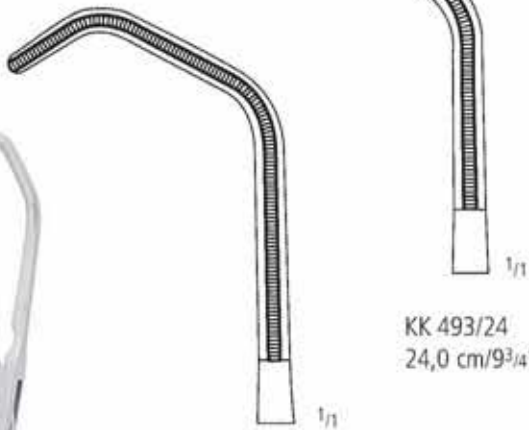

KK 493/24  
 24,0 cm/9<sup>3</sup>/<sub>4</sub>"

KK 493/20  
 20,5 cm/8"



SATINSKY





Atrauma-Klemmen  
 Atrauma Forceps  
 Pinzas Atrauma  
 Pincès atraumatiques  
 Pinze Atrauma



DE BAKEY



LAMBERT-KAY

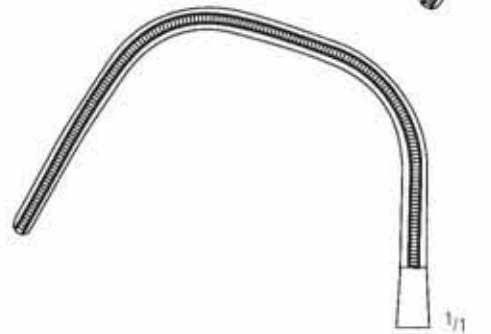

KK 495/01  
 21,0 cm/8 1/2"

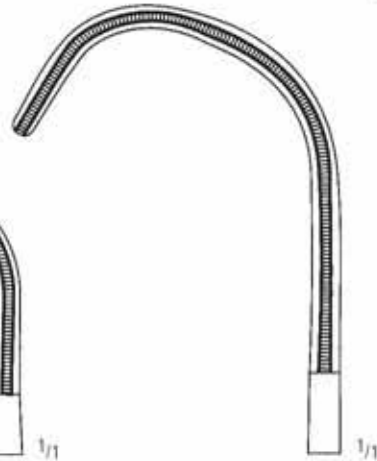

KK 495/02  
 21,0 cm/8 1/2"



DE BAKEY  
 KK 501/17  
 17,0 cm/6 3/4"



DE BAKEY-BAHNSON

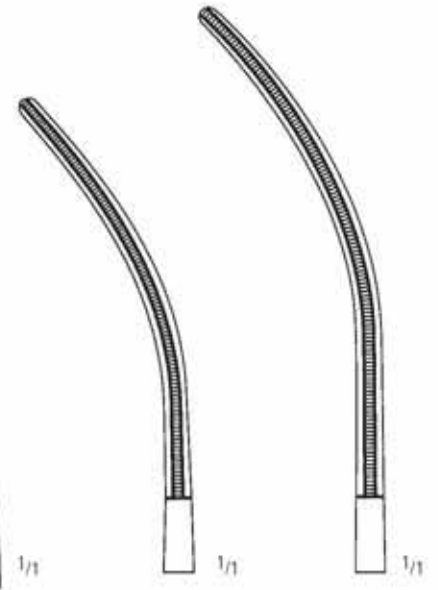

KK 503/23  
 23,0 cm/9"

KK 503/24  
 24,0 cm/9 1/2"

KK 503/25  
 25,0 cm/10"

AA  
 AB  
 AC  
 AD  
 AE  
 AF  
 AK  
 AL  
 AO  
 KA  
 KK  
 X



Atrauma-Klemmen  
 Atrauma Forceps  
 Pinzas Atrauma  
 Pincès atraumatiques  
 Pinze Atrauma



**DE BAKEY**



**HARKEN**

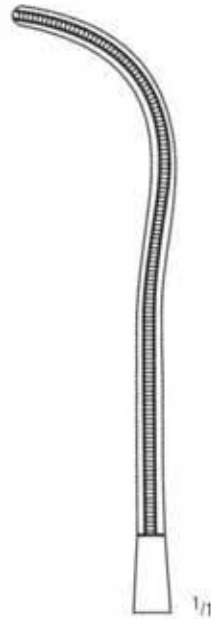

KK 505/01  
 24,0 cm/9 1/2"



KK 505/02  
 24,0 cm/9 1/2"

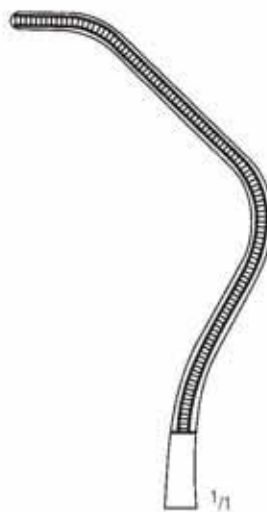

KK 505/03  
 24,0 cm/9 1/2"



KK 505/04  
 24,0 cm/9 1/2"

Atrauma-Klemmen  
 Atrauma Forceps  
 Pinzas Atrauma  
 Pincès atraumatiques  
 Pinze Atrauma



DE BAKEY



**WEBER**  
 KK 509/01  
 26,0 cm/10<sup>1</sup>/<sub>4</sub>"

**WEBER**  
 KK 509/02  
 26,0 cm/10<sup>1</sup>/<sub>4</sub>"

AA  
 AB  
 AC  
 AD  
 AE  
 AF  
 AK  
 AL  
 AO  
 KA  
 KK  
 X



Atrauma-Klemmen  
 Atrauma Forceps  
 Pinzas Atrauma  
 Pincès atraumatiques  
 Pinze Atrauma



DE BAKEY

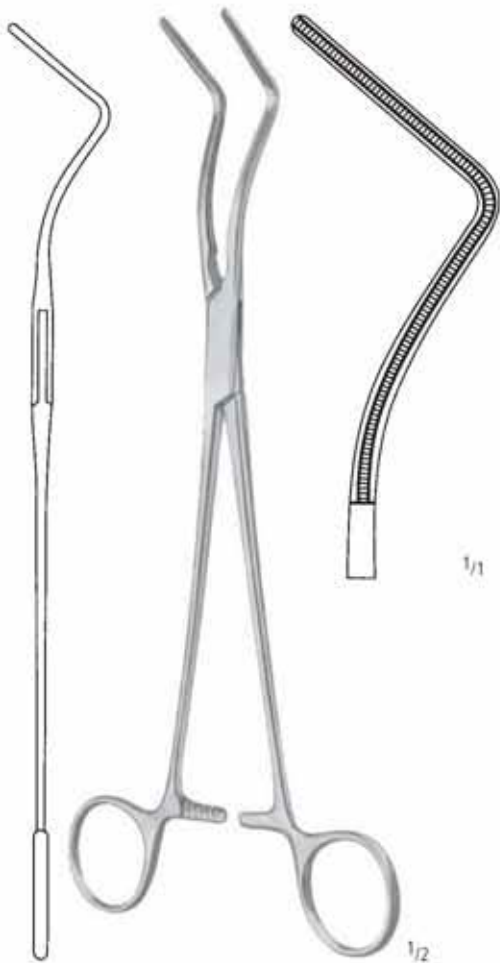

LEES  
 KK 511/25  
 25,0 cm/10"



LEES



KK 512/23  
 23,0 cm/9"

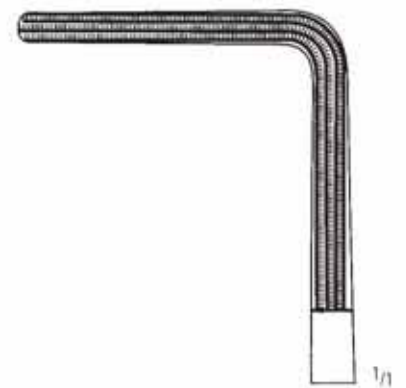

KK 512/25  
 25,0 cm/10"

Atrauma-Klemmen  
 Atrauma Forceps  
 Pinzas Atrauma  
 Pincès atraumatiques  
 Pinze Atrauma



DE BAKEY



Draufsicht  
 Top view  
 Vista de arriba  
 Vue en plan  
 Vista da sopra

**DE BAKEY**  
 KK 513/27  
 27,0 cm/10<sup>1</sup>/<sub>2</sub>"

AA  
 AB  
 AC  
 AD  
 AE  
 AF  
 AK  
 AL  
 AO  
 KA  
 KK  
 X

KK

Atrauma-Klemmen  
 Atrauma Forceps  
 Pinzas Atrauma  
 Pincès atraumatiques  
 Pinze Atrauma



**DE BAKEY**

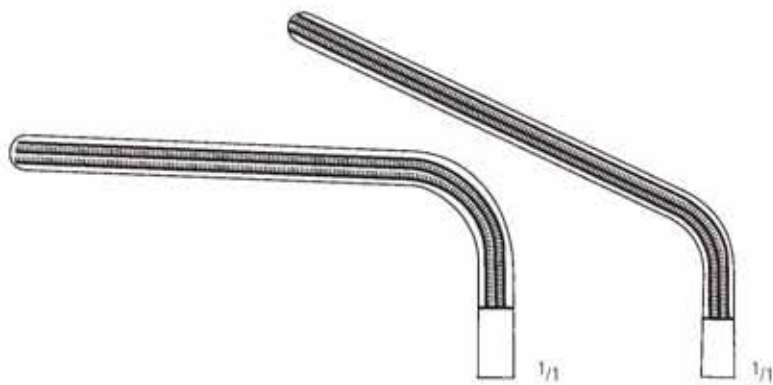

KK 515/18  
 18,0 cm/7"

KK 515/20  
 20,0 cm/8"

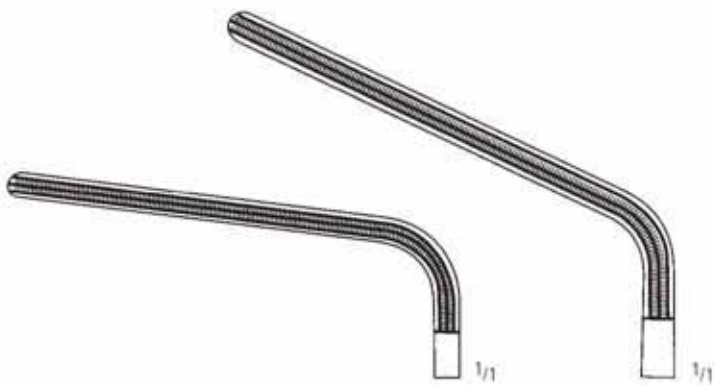

KK 515/23  
 23,0 cm/9"

KK 515/25  
 25,0 cm/10"



**MORRIS-DE BAKEY**

Atrauma-Klemmen  
 Atrauma Forceps  
 Pinzas Atrauma  
 Pincas atraumatiques  
 Pinze Atrauma



DE BAKEY



**OCHSNER**  
 KK 517/23  
 23,5 cm/9<sup>1</sup>/<sub>4</sub>"

1/2



**DIETRICH**  
 KK 519/21  
 21,0 cm/8<sup>1</sup>/<sub>4</sub>"

1/2



**GREGORY**

1/2



KK 521/14  
 14,0 cm/5<sup>1</sup>/<sub>2</sub>"

1/1



KK 521/16  
 16,0 cm/6<sup>1</sup>/<sub>4</sub>"

1/1

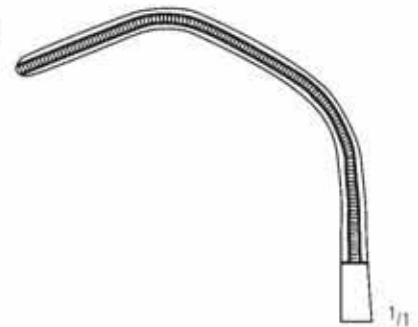

KK 521/18  
 18,0 cm/7"

1/1

AA  
 AB  
 AC  
 AD  
 AE  
 AF  
 AK  
 AL  
 AO  
 KA  
 KK  
 X



Atrauma-Klemmen  
 Atrauma Forceps  
 Pinzas Atrauma  
 Pincès atraumatiques  
 Pinze Atrauma



**DE BAKEY**



1/2



1/1

KK 523/17  
 17,0 cm/6 1/2"



1/1

KK 523/18  
 18,0 cm/7"



1/1

KK 523/19  
 18,5 cm/7 1/4"

**DALE**

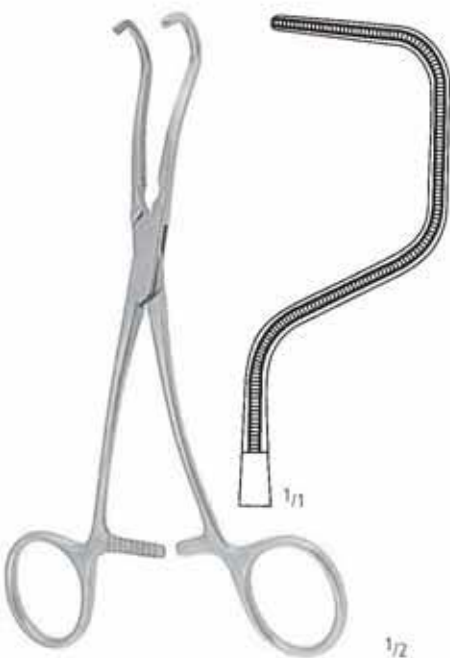

1/2

**DALE**  
 KK 525/18  
 18,5 cm/7"



1/2

**DERRA**



1/1

KK 527/16  
 16,0 cm/6 1/4"



1/1

KK 527/17  
 17,0 cm/6 3/4"



1/1

KK 527/18  
 18,0 cm/7"

Atrauma-Klemmen  
 Atrauma Forceps  
 Pinzas Atrauma  
 Pincès atraumatiques  
 Pinze Atrauma



DE BAKEY



KK 531/16  
 16,0 cm/6<sup>1</sup>/<sub>4</sub>"



KK 531/17  
 17,0 cm/6<sup>3</sup>/<sub>4</sub>"



BECK  
 KK 535/17  
 17,0 cm/6<sup>3</sup>/<sub>4</sub>"

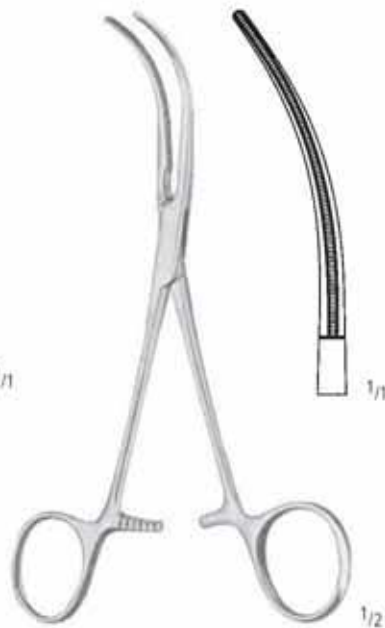

GLOVER  
 KK 537/17  
 17,0 cm/6<sup>3</sup>/<sub>4</sub>"

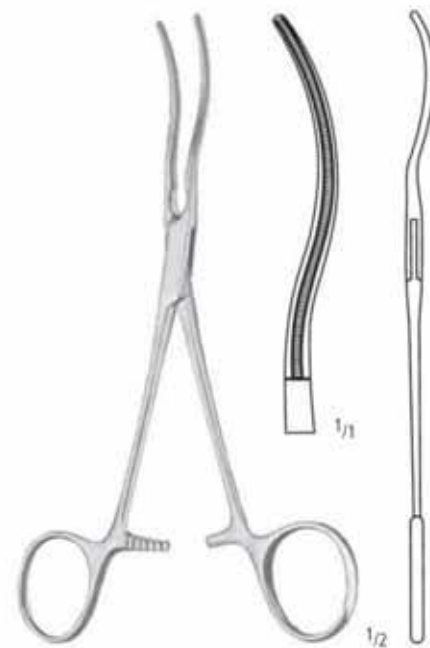

KK 539/17  
 17,0 cm/6<sup>3</sup>/<sub>4</sub>"

AA  
 AB  
 AC  
 AD  
 AE  
 AF  
 AK  
 AL  
 AO  
 KA  
 KK  
 X

Atrauma-Klemmen  
 Atrauma Forceps  
 Pinzas Atrauma  
 Pincès atraumatiques  
 Pinze Atrauma



DE BAKEY



DE BAKEY  
 KK 540/17  
 17,0 cm/6<sup>3</sup>/<sub>4</sub>"

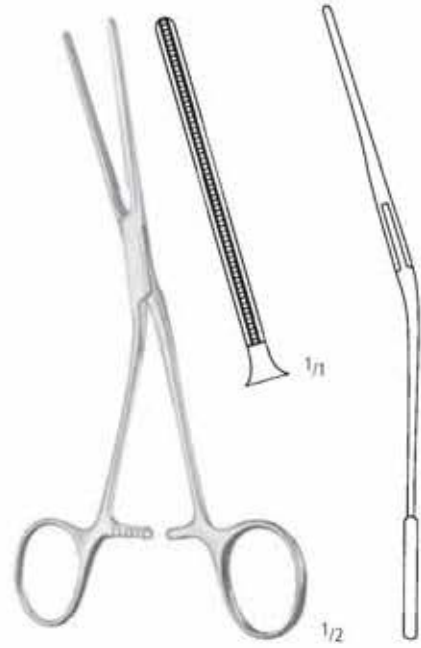

DE BAKEY  
 KK 541/17  
 17,0 cm/6<sup>3</sup>/<sub>4</sub>"

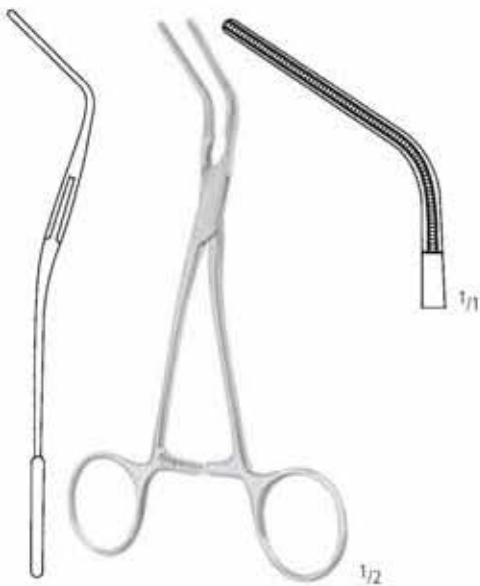

DE BAKEY  
 KK 543/15  
 15,0 cm/6"

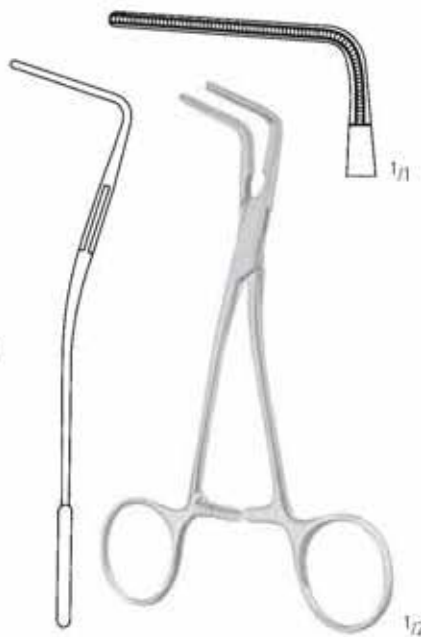

DE BAKEY  
 KK 545/15  
 15,0 cm/6"

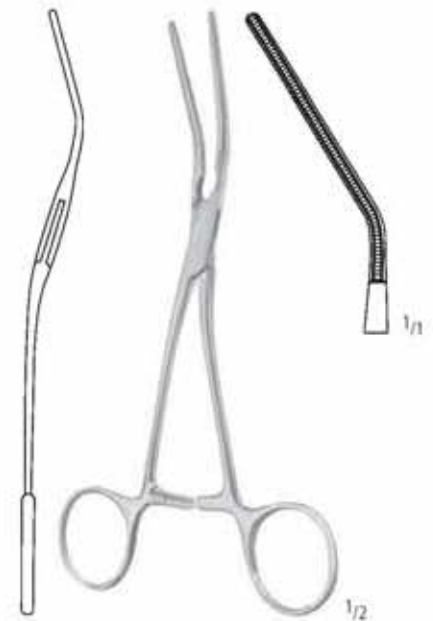

DE BAKEY  
 KK 547/16  
 16,0 cm/6<sup>1</sup>/<sub>4</sub>"

Atrauma-Klemmen  
 Atrauma Forceps  
 Pinzas Atrauma  
 Pincès atraumatiques  
 Pinze Atrauma



**JAVID**  
 KK 561/18  
 18,0 cm/7"



**JAVID**  
 KK 561/19  
 19,0 cm/7 1/2"



**COOLEY**

24 Charr.	16,0 cm/6 1/4"	KK 565/24
26 Charr.	16,0 cm/6 1/4"	KK 565/26
28 Charr.	20,0 cm/8"	KK 565/28
30 Charr.	20,0 cm/8"	KK 565/30
32 Charr.	20,0 cm/8"	KK 565/32
36 Charr.	20,0 cm/8"	KK 565/36

AA  
 AB  
 AC  
 AD  
 AE  
 AF  
 AG  
 AH  
 AI  
 AJ  
 AK  
 AL  
 AM  
 AN  
 AO  
 AP  
 AQ  
 AR  
 AS  
 AT  
 AU  
 AV  
 AW  
 AX  
 AY  
 AZ  
 BA  
 BB  
 BC  
 BD  
 BE  
 BF  
 BG  
 BH  
 BI  
 BJ  
 BK  
 BL  
 BM  
 BN  
 BO  
 BP  
 BQ  
 BR  
 BS  
 BT  
 BU  
 BV  
 BW  
 BX  
 BY  
 BZ  
 CA  
 CB  
 CC  
 CD  
 CE  
 CF  
 CG  
 CH  
 CI  
 CJ  
 CK  
 CL  
 CM  
 CN  
 CO  
 CP  
 CQ  
 CR  
 CS  
 CT  
 CU  
 CV  
 CW  
 CX  
 CY  
 CZ  
 DA  
 DB  
 DC  
 DD  
 DE  
 DF  
 DG  
 DH  
 DI  
 DJ  
 DK  
 DL  
 DM  
 DN  
 DO  
 DP  
 DQ  
 DR  
 DS  
 DT  
 DU  
 DV  
 DW  
 DX  
 DY  
 DZ  
 EA  
 EB  
 EC  
 ED  
 EE  
 EF  
 EG  
 EH  
 EI  
 EJ  
 EK  
 EL  
 EM  
 EN  
 EO  
 EP  
 EQ  
 ER  
 ES  
 ET  
 EU  
 EV  
 EW  
 EX  
 EY  
 EZ  
 FA  
 FB  
 FC  
 FD  
 FE  
 FF  
 FG  
 FH  
 FI  
 FJ  
 FK  
 FL  
 FM  
 FN  
 FO  
 FP  
 FQ  
 FR  
 FS  
 FT  
 FU  
 FV  
 FW  
 FX  
 FY  
 FZ  
 GA  
 GB  
 GC  
 GD  
 GE  
 GF  
 GG  
 GH  
 GI  
 GJ  
 GK  
 GL  
 GM  
 GN  
 GO  
 GP  
 GQ  
 GR  
 GS  
 GT  
 GU  
 GV  
 GW  
 GX  
 GY  
 GZ  
 HA  
 HB  
 HC  
 HD  
 HE  
 HF  
 HG  
 HH  
 HI  
 HJ  
 HK  
 HL  
 HM  
 HN  
 HO  
 HP  
 HQ  
 HR  
 HS  
 HT  
 HU  
 HV  
 HW  
 HX  
 HY  
 HZ  
 IA  
 IB  
 IC  
 ID  
 IE  
 IF  
 IG  
 IH  
 II  
 IJ  
 IK  
 IL  
 IM  
 IN  
 IO  
 IP  
 IQ  
 IR  
 IS  
 IT  
 IU  
 IV  
 IW  
 IX  
 IY  
 IZ  
 JA  
 JB  
 JC  
 JD  
 JE  
 JF  
 JG  
 JH  
 JI  
 JJ  
 JK  
 JL  
 JM  
 JN  
 JO  
 JP  
 JQ  
 JR  
 JS  
 JT  
 JU  
 JV  
 JW  
 JX  
 JY  
 JZ  
 KA  
 KB  
 KC  
 KD  
 KE  
 KF  
 KG  
 KH  
 KI  
 KJ  
 KK  
 KL  
 KM  
 KN  
 KO  
 KP  
 KQ  
 KR  
 KS  
 KT  
 KU  
 KV  
 KW  
 KX  
 KY  
 KZ  
 LA  
 LB  
 LC  
 LD  
 LE  
 LF  
 LG  
 LH  
 LI  
 LJ  
 LK  
 LL  
 LM  
 LN  
 LO  
 LP  
 LQ  
 LR  
 LS  
 LT  
 LU  
 LV  
 LW  
 LX  
 LY  
 LZ  
 MA  
 MB  
 MC  
 MD  
 ME  
 MF  
 MG  
 MH  
 MI  
 MJ  
 MK  
 ML  
 MM  
 MN  
 MO  
 MP  
 MQ  
 MR  
 MS  
 MT  
 MU  
 MV  
 MW  
 MX  
 MY  
 MZ  
 NA  
 NB  
 NC  
 ND  
 NE  
 NF  
 NG  
 NH  
 NI  
 NJ  
 NK  
 NL  
 NM  
 NN  
 NO  
 NP  
 NQ  
 NR  
 NS  
 NT  
 NU  
 NV  
 NW  
 NX  
 NY  
 NZ  
 OA  
 OB  
 OC  
 OD  
 OE  
 OF  
 OG  
 OH  
 OI  
 OJ  
 OK  
 OL  
 OM  
 ON  
 OO  
 OP  
 OQ  
 OR  
 OS  
 OT  
 OU  
 OV  
 OW  
 OX  
 OY  
 OZ  
 PA  
 PB  
 PC  
 PD  
 PE  
 PF  
 PG  
 PH  
 PI  
 PJ  
 PK  
 PL  
 PM  
 PN  
 PO  
 PP  
 PQ  
 PR  
 PS  
 PT  
 PU  
 PV  
 PW  
 PX  
 PY  
 PZ  
 QA  
 QB  
 QC  
 QD  
 QE  
 QF  
 QG  
 QH  
 QI  
 QJ  
 QK  
 QL  
 QM  
 QN  
 QO  
 QP  
 QQ  
 QR  
 QS  
 QT  
 QU  
 QV  
 QW  
 QX  
 QY  
 QZ  
 RA  
 RB  
 RC  
 RD  
 RE  
 RF  
 RG  
 RH  
 RI  
 RJ  
 RK  
 RL  
 RM  
 RN  
 RO  
 RP  
 RQ  
 RR  
 RS  
 RT  
 RU  
 RV  
 RW  
 RX  
 RY  
 RZ  
 SA  
 SB  
 SC  
 SD  
 SE  
 SF  
 SG  
 SH  
 SI  
 SJ  
 SK  
 SL  
 SM  
 SN  
 SO  
 SP  
 SQ  
 SR  
 SS  
 ST  
 SU  
 SV  
 SW  
 SX  
 SY  
 SZ  
 TA  
 TB  
 TC  
 TD  
 TE  
 TF  
 TG  
 TH  
 TI  
 TJ  
 TK  
 TL  
 TM  
 TN  
 TO  
 TP  
 TQ  
 TR  
 TS  
 TT  
 TU  
 TV  
 TW  
 TX  
 TY  
 TZ  
 UA  
 UB  
 UC  
 UD  
 UE  
 UF  
 UG  
 UH  
 UI  
 UJ  
 UK  
 UL  
 UM  
 UN  
 UO  
 UP  
 UQ  
 UR  
 US  
 UT  
 UU  
 UV  
 UW  
 UX  
 UY  
 UZ  
 VA  
 VB  
 VC  
 VD  
 VE  
 VF  
 VG  
 VH  
 VI  
 VJ  
 VK  
 VL  
 VM  
 VN  
 VO  
 VP  
 VQ  
 VR  
 VS  
 VT  
 VU  
 VV  
 VW  
 VX  
 VY  
 VZ  
 WA  
 WB  
 WC  
 WD  
 WE  
 WF  
 WG  
 WH  
 WI  
 WJ  
 WK  
 WL  
 WM  
 WN  
 WO  
 WP  
 WQ  
 WR  
 WS  
 WT  
 WU  
 WV  
 WW  
 WX  
 WY  
 WZ  
 XA  
 XB  
 XC  
 XD  
 XE  
 XF  
 XG  
 XH  
 XI  
 XJ  
 XK  
 XL  
 XM  
 XN  
 XO  
 XP  
 XQ  
 XR  
 XS  
 XT  
 XU  
 XV  
 XW  
 XX  
 XY  
 XZ  
 YA  
 YB  
 YC  
 YD  
 YE  
 YF  
 YG  
 YH  
 YI  
 YJ  
 YK  
 YL  
 YM  
 YN  
 YO  
 YP  
 YQ  
 YR  
 YS  
 YT  
 YU  
 YV  
 YW  
 YX  
 YY  
 YZ  
 ZA  
 ZB  
 ZC  
 ZD  
 ZE  
 ZF  
 ZG  
 ZH  
 ZI  
 ZJ  
 ZK  
 ZL  
 ZM  
 ZN  
 ZO  
 ZP  
 ZQ  
 ZR  
 ZS  
 ZT  
 ZU  
 ZV  
 ZW  
 ZX  
 ZY  
 ZZ

Atrauma-Klemmen  
 Atrauma Forceps  
 Pinzas Atrauma  
 Pincès atraumatiques  
 Pinze Atrauma



**COOLEY**



**COOLEY**  
 KK 571/20  
 20,0 cm/8"

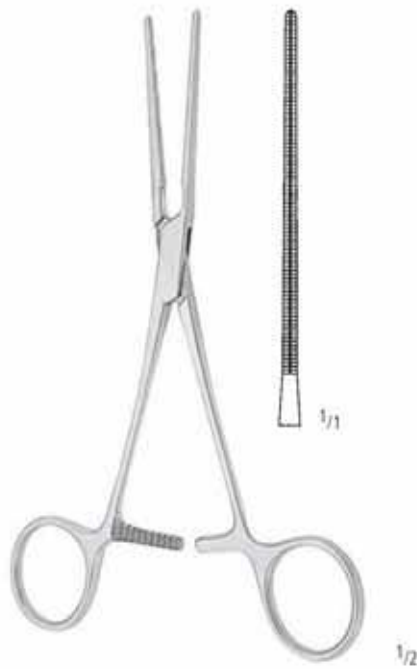

**COOLEY**  
 KK 574/17  
 17,0 cm/6<sup>3</sup>/<sub>4</sub>"



**COOLEY**  
 KK 575/17  
 17,0 cm/6<sup>3</sup>/<sub>4</sub>"

graduiert - graduated



Atrauma-Klemmen  
 Atrauma Forceps  
 Pinzas Atrauma  
 Pincès atraumatiques  
 Pinze Atrauma



COOLEY



**COOLEY**  
 KK 577/17  
 17,0 cm/6<sup>3</sup>/<sub>4</sub>"

graduiert - graduated



**COOLEY**  
 KK 579/17  
 17,0 cm/6<sup>3</sup>/<sub>4</sub>"

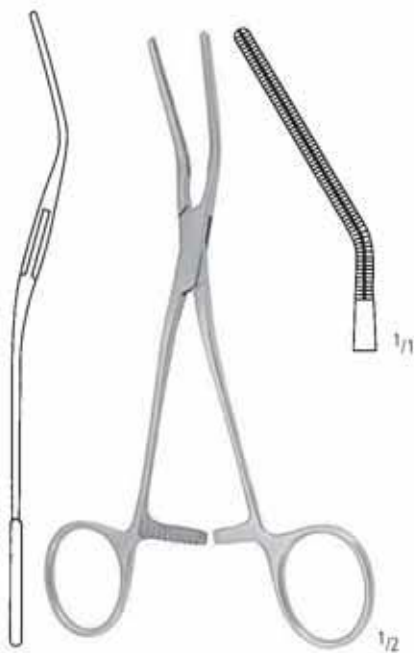

**COOLEY**  
 KK 581/17  
 17,0 cm/6<sup>3</sup>/<sub>4</sub>"

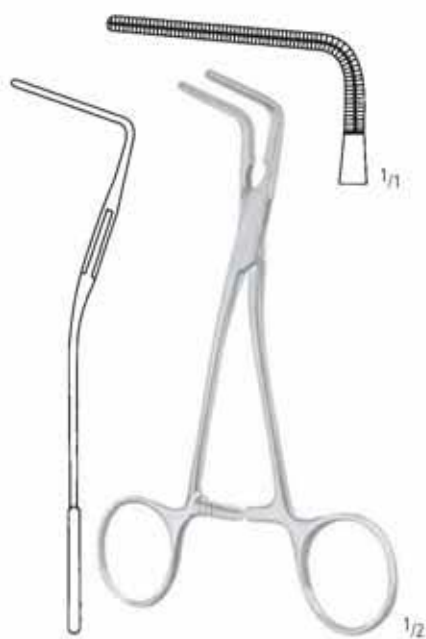

**COOLEY**  
 KK 583/15  
 15,0 cm/6"

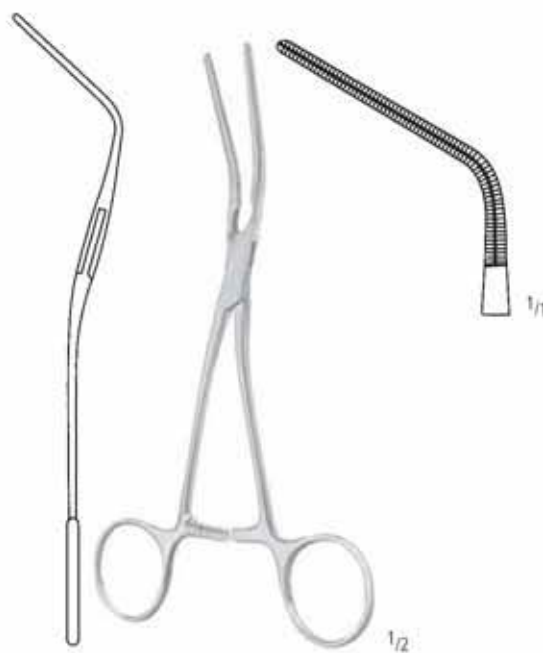

**COOLEY**  
 KK 585/16  
 15,5 cm/6<sup>1</sup>/<sub>8</sub>"

AA

AB

AC

AD

AE

AF

AK

AL

AO

KA

**KK**

X



Atrauma-Klemmen  
 Atrauma Forceps  
 Pinzas Atrauma  
 Pincès atraumatiques  
 Pinze Atrauma



**COOLEY**



**COOLEY**



KK 587/16  
 16,0 cm/6<sup>1</sup>/<sub>4</sub>"

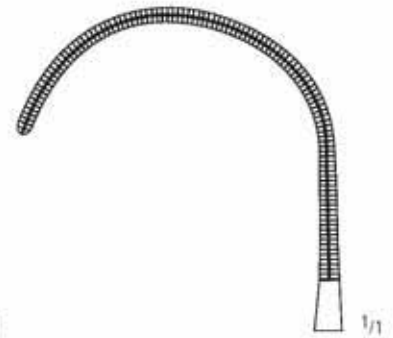

KK 587/17  
 17,0 cm/6<sup>3</sup>/<sub>4</sub>"



**COOLEY**  
 KK 589/17  
 17,0 cm/6<sup>3</sup>/<sub>4</sub>"

graduiert - graduated



**COOLEY**  
 KK 591/16  
 16,0 cm/6<sup>1</sup>/<sub>4</sub>"

Atrauma-Klemmen  
 Atrauma Forceps  
 Pinzas Atrauma  
 Pincès atraumatiques  
 Pinze Atrauma



COOLEY



COOLEY-DERRA

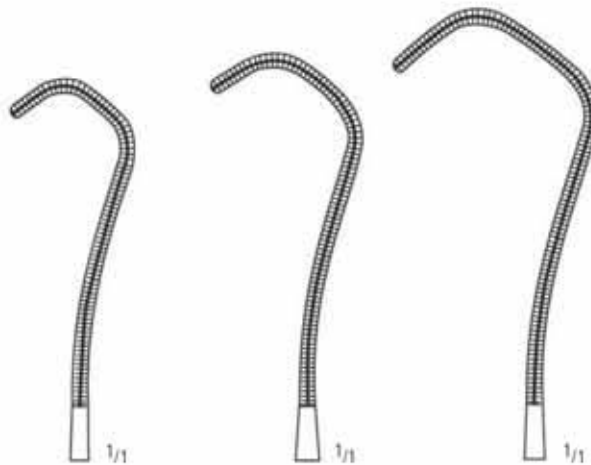

KK 593/16  
 16,0 cm/6<sup>1</sup>/<sub>4</sub>"

KK 593/17  
 17,0 cm/6<sup>3</sup>/<sub>4</sub>"

KK 593/18  
 18,0 cm/7"

graduiert - graduated



BECK  
 KK 595/17  
 17,0 cm/6<sup>3</sup>/<sub>4</sub>"

AA  
 AB  
 AC  
 AD  
 AE  
 AF  
 AK  
 AL  
 AO  
 KA  
 KK  
 X

Atrauma-Klemmen  
 Atrauma Forceps  
 Pinzas Atrauma  
 Pincès atraumatiques  
 Pinze Atrauma



**DARDIK**



KK 597/01  
 13,0 cm/5<sup>1</sup>/<sub>4</sub>"

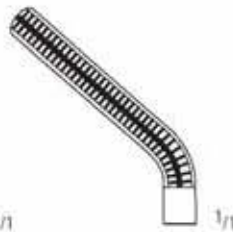

KK 597/02  
 14,5 cm/5<sup>3</sup>/<sub>4</sub>"



KK 597/03  
 15,0 cm/6"



KK 597/04  
 15,0 cm/6"

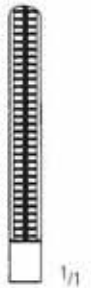

KK 597/05  
 15,0 cm/6"



**DARDIK**



KK 599/01  
 13,5 cm/5<sup>1</sup>/<sub>2</sub>"

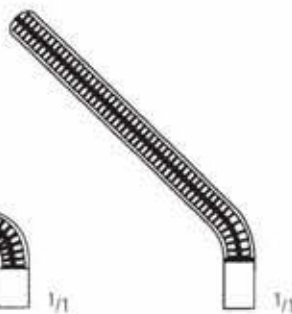

KK 599/02  
 16,0 cm/6<sup>1</sup>/<sub>4</sub>"

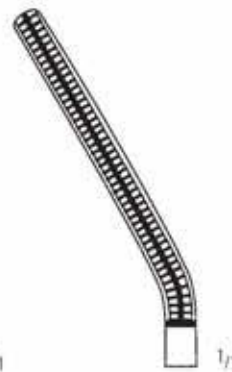

KK 599/03  
 17,0 cm/6<sup>3</sup>/<sub>4</sub>"



KK 599/04  
 17,0 cm/6<sup>3</sup>/<sub>4</sub>"

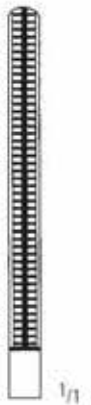

KK 599/05  
 17,0 cm/6<sup>3</sup>/<sub>4</sub>"

Atrauma-Klemmen  
 Atrauma Forceps  
 Pinzas Atrauma  
 Pincès atraumatiques  
 Pinze Atrauma

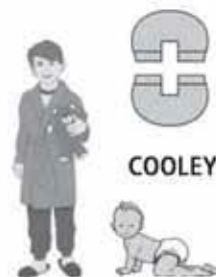

KK 600/14  
 14,0 cm/5 1/2"

KK 601/14  
 14,0 cm/5 1/2"

COOLEY

graduiert - graduated



COOLEY  
 KK 603/14  
 14,0 cm/5 1/2"



COOLEY  
 KK 605/14  
 14,0 cm/5 1/2"



COOLEY  
 KK 607/14  
 14,0 cm/5 1/2"

AA  
 AB  
 AC  
 AD  
 AE  
 AF  
 AG  
 AH  
 AI  
 AJ  
 AK  
 AL  
 AM  
 AN  
 AO  
 AP  
 AQ  
 AR  
 AS  
 AT  
 AU  
 AV  
 AW  
 AX  
 AY  
 AZ  
 BA  
 BB  
 BC  
 BD  
 BE  
 BF  
 BG  
 BH  
 BI  
 BJ  
 BK  
 BL  
 BM  
 BN  
 BO  
 BP  
 BQ  
 BR  
 BS  
 BT  
 BU  
 BV  
 BW  
 BX  
 BY  
 BZ  
 CA  
 CB  
 CC  
 CD  
 CE  
 CF  
 CG  
 CH  
 CI  
 CJ  
 CK  
 CL  
 CM  
 CN  
 CO  
 CP  
 CQ  
 CR  
 CS  
 CT  
 CU  
 CV  
 CW  
 CX  
 CY  
 CZ  
 DA  
 DB  
 DC  
 DD  
 DE  
 DF  
 DG  
 DH  
 DI  
 DJ  
 DK  
 DL  
 DM  
 DN  
 DO  
 DP  
 DQ  
 DR  
 DS  
 DT  
 DU  
 DV  
 DW  
 DX  
 DY  
 DZ  
 EA  
 EB  
 EC  
 ED  
 EE  
 EF  
 EG  
 EH  
 EI  
 EJ  
 EK  
 EL  
 EM  
 EN  
 EO  
 EP  
 EQ  
 ER  
 ES  
 ET  
 EU  
 EV  
 EW  
 EX  
 EY  
 EZ  
 FA  
 FB  
 FC  
 FD  
 FE  
 FF  
 FG  
 FH  
 FI  
 FJ  
 FK  
 FL  
 FM  
 FN  
 FO  
 FP  
 FQ  
 FR  
 FS  
 FT  
 FU  
 FV  
 FW  
 FX  
 FY  
 FZ  
 GA  
 GB  
 GC  
 GD  
 GE  
 GF  
 GG  
 GH  
 GI  
 GJ  
 GK  
 GL  
 GM  
 GN  
 GO  
 GP  
 GQ  
 GR  
 GS  
 GT  
 GU  
 GV  
 GW  
 GX  
 GY  
 GZ  
 HA  
 HB  
 HC  
 HD  
 HE  
 HF  
 HG  
 HH  
 HI  
 HJ  
 HK  
 HL  
 HM  
 HN  
 HO  
 HP  
 HQ  
 HR  
 HS  
 HT  
 HU  
 HV  
 HW  
 HX  
 HY  
 HZ  
 IA  
 IB  
 IC  
 ID  
 IE  
 IF  
 IG  
 IH  
 II  
 IJ  
 IK  
 IL  
 IM  
 IN  
 IO  
 IP  
 IQ  
 IR  
 IS  
 IT  
 IU  
 IV  
 IW  
 IX  
 IY  
 IZ  
 JA  
 JB  
 JC  
 JD  
 JE  
 JF  
 JG  
 JH  
 JI  
 JJ  
 JK  
 JL  
 JM  
 JN  
 JO  
 JP  
 JQ  
 JR  
 JS  
 JT  
 JU  
 JV  
 JW  
 JX  
 JY  
 JZ  
 KA  
 KB  
 KC  
 KD  
 KE  
 KF  
 KG  
 KH  
 KI  
 KJ  
 KK  
 KL  
 KM  
 KN  
 KO  
 KP  
 KQ  
 KR  
 KS  
 KT  
 KU  
 KV  
 KW  
 KX  
 KY  
 KZ  
 LA  
 LB  
 LC  
 LD  
 LE  
 LF  
 LG  
 LH  
 LI  
 LJ  
 LK  
 LL  
 LM  
 LN  
 LO  
 LP  
 LQ  
 LR  
 LS  
 LT  
 LU  
 LV  
 LW  
 LX  
 LY  
 LZ  
 MA  
 MB  
 MC  
 MD  
 ME  
 MF  
 MG  
 MH  
 MI  
 MJ  
 MK  
 ML  
 MM  
 MN  
 MO  
 MP  
 MQ  
 MR  
 MS  
 MT  
 MU  
 MV  
 MW  
 MX  
 MY  
 MZ  
 NA  
 NB  
 NC  
 ND  
 NE  
 NF  
 NG  
 NH  
 NI  
 NJ  
 NK  
 NL  
 NM  
 NN  
 NO  
 NP  
 NQ  
 NR  
 NS  
 NT  
 NU  
 NV  
 NW  
 NX  
 NY  
 NZ  
 OA  
 OB  
 OC  
 OD  
 OE  
 OF  
 OG  
 OH  
 OI  
 OJ  
 OK  
 OL  
 OM  
 ON  
 OO  
 OP  
 OQ  
 OR  
 OS  
 OT  
 OU  
 OV  
 OW  
 OX  
 OY  
 OZ  
 PA  
 PB  
 PC  
 PD  
 PE  
 PF  
 PG  
 PH  
 PI  
 PJ  
 PK  
 PL  
 PM  
 PN  
 PO  
 PP  
 PQ  
 PR  
 PS  
 PT  
 PU  
 PV  
 PW  
 PX  
 PY  
 PZ  
 QA  
 QB  
 QC  
 QD  
 QE  
 QF  
 QG  
 QH  
 QI  
 QJ  
 QK  
 QL  
 QM  
 QN  
 QO  
 QP  
 QQ  
 QR  
 QS  
 QT  
 QU  
 QV  
 QW  
 QX  
 QY  
 QZ  
 RA  
 RB  
 RC  
 RD  
 RE  
 RF  
 RG  
 RH  
 RI  
 RJ  
 RK  
 RL  
 RM  
 RN  
 RO  
 RP  
 RQ  
 RR  
 RS  
 RT  
 RU  
 RV  
 RW  
 RX  
 RY  
 RZ  
 SA  
 SB  
 SC  
 SD  
 SE  
 SF  
 SG  
 SH  
 SI  
 SJ  
 SK  
 SL  
 SM  
 SN  
 SO  
 SP  
 SQ  
 SR  
 SS  
 ST  
 SU  
 SV  
 SW  
 SX  
 SY  
 SZ  
 TA  
 TB  
 TC  
 TD  
 TE  
 TF  
 TG  
 TH  
 TI  
 TJ  
 TK  
 TL  
 TM  
 TN  
 TO  
 TP  
 TQ  
 TR  
 TS  
 TT  
 TU  
 TV  
 TW  
 TX  
 TY  
 TZ  
 UA  
 UB  
 UC  
 UD  
 UE  
 UF  
 UG  
 UH  
 UI  
 UJ  
 UK  
 UL  
 UM  
 UN  
 UO  
 UP  
 UQ  
 UR  
 US  
 UT  
 UY  
 UZ  
 VA  
 VB  
 VC  
 VD  
 VE  
 VF  
 VG  
 VH  
 VI  
 VJ  
 VK  
 VL  
 VM  
 VN  
 VO  
 VP  
 VQ  
 VR  
 VS  
 VT  
 VU  
 VV  
 VW  
 VX  
 VY  
 VZ  
 WA  
 WB  
 WC  
 WD  
 WE  
 WF  
 WG  
 WH  
 WI  
 WJ  
 WK  
 WL  
 WM  
 WN  
 WO  
 WP  
 WQ  
 WR  
 WS  
 WT  
 WU  
 WV  
 WW  
 WX  
 WY  
 WZ  
 XA  
 XB  
 XC  
 XD  
 XE  
 XF  
 XG  
 XH  
 XI  
 XJ  
 XK  
 XL  
 XM  
 XN  
 XO  
 XP  
 XQ  
 XR  
 XS  
 XT  
 XU  
 XV  
 XW  
 XX  
 XY  
 XZ  
 YA  
 YB  
 YC  
 YD  
 YE  
 YF  
 YG  
 YH  
 YI  
 YJ  
 YK  
 YL  
 YM  
 YN  
 YO  
 YP  
 YQ  
 YR  
 YS  
 YT  
 YU  
 YV  
 YW  
 YX  
 YZ  
 ZA  
 ZB  
 ZC  
 ZD  
 ZE  
 ZF  
 ZG  
 ZH  
 ZI  
 ZJ  
 ZK  
 ZL  
 ZM  
 ZN  
 ZO  
 ZP  
 ZQ  
 ZR  
 ZS  
 ZT  
 ZU  
 ZV  
 ZW  
 ZX  
 ZY  
 ZZ

Atrauma-Klemmen  
 Atrauma Forceps  
 Pinzas Atrauma  
 Pincès atraumatiques  
 Pinze Atrauma

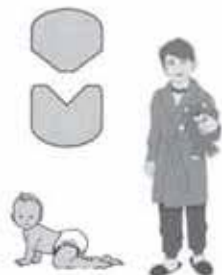

KK 611/01  
 14,0 cm/5 1/2"



KK 611/02  
 14,0 cm/5 1/2"



KK 611/03  
 14,0 cm/5 1/2"



KK 611/04  
 13,0 cm/5"



KK 611/05  
 14,0 cm/5 1/2"



KK 611/06  
 13,0 cm/5"

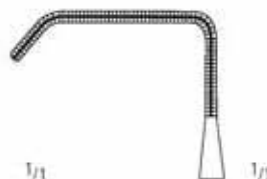

KK 611/07  
 13,0 cm/5"



KK 611/08  
 14,0 cm/5 1/2"



KK 611/09  
 13,5 cm/5 1/4"

Atrauma-Klemmen  
 Atrauma Forceps  
 Pinzas Atrauma  
 Pincès atraumatiques  
 Pinze Atrauma

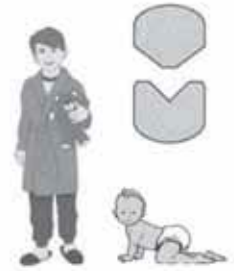

KK 620/16  
 16,5 cm/6 1/2"



KK 621/16  
 16,0 cm/6 1/4"



KK 623/15  
 15,0 cm/6"



KK 625/15  
 15,0 cm/6"



KK 627/15  
 15,5 cm/6 1/8"

AA  
 AB  
 AC  
 AD  
 AE  
 AF  
 AK  
 AL  
 AO  
 KA  
 KK  
 X



Atrauma-Klemmen  
 Atrauma Forceps  
 Pinzas Atrauma  
 Pincès atraumatiques  
 Pinze Atrauma



KK 635/01  
 13,0 cm/5"



KK 635/02  
 13,0 cm/5"



KK 635/03  
 11,0 cm/4<sup>1</sup>/<sub>2</sub>"



**CASTANEDA**



KK 635/04  
 12,0 cm/4<sup>3</sup>/<sub>4</sub>"



KK 635/05  
 12,0 cm/4<sup>3</sup>/<sub>4</sub>"

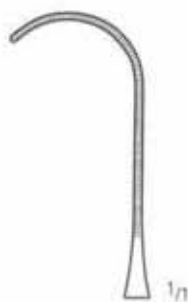

KK 635/06  
 12,0 cm/4<sup>3</sup>/<sub>4</sub>"



KK 635/07  
 14,0 cm/4<sup>3</sup>/<sub>4</sub>"

graduiert - graduated

Atrauma-Klemmen  
 Atrauma Forceps  
 Pinzas Atrauma  
 Pincas atraumatiques  
 Pinze Atrauma

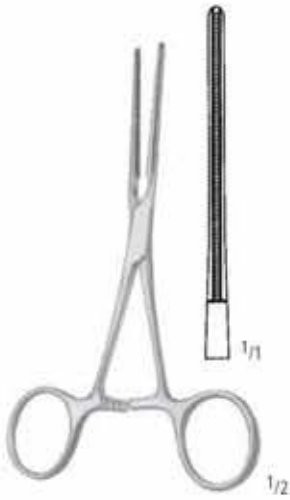

**DE BAKEY**  
 KK 637/12  
 12,0 cm/4<sup>3</sup>/<sub>4</sub>"

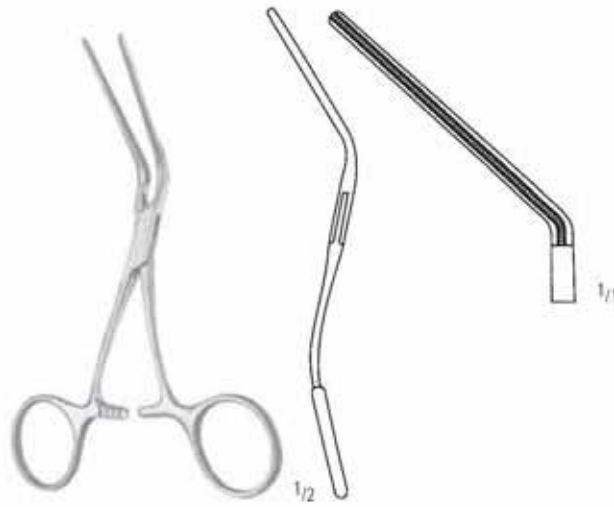

**DE BAKEY**  
 KK 639/13  
 13,0 cm/5<sup>1</sup>/<sub>4</sub>"



**DE BAKEY**  
 KK 641/10  
 10,0 cm/4"



**DE BAKEY**  
 KK 643/11  
 11,0 cm/4<sup>1</sup>/<sub>4</sub>"



**DE BAKEY**  
 KK 645/12  
 12,0 cm/4<sup>3</sup>/<sub>4</sub>"

AA  
 AB  
 AC  
 AD  
 AE  
 AF  
 AG  
 AH  
 AI  
 AJ  
 AK  
 AL  
 AM  
 AN  
 AO  
 AP  
 AQ  
 AR  
 AS  
 AT  
 AU  
 AV  
 AW  
 AX  
 AY  
 AZ

**KK**

Atrauma-Klemmen  
 Atrauma Forceps  
 Pinzas Atrauma  
 Pincès atraumatiques  
 Pinze Atrauma



**DE BAKEY**

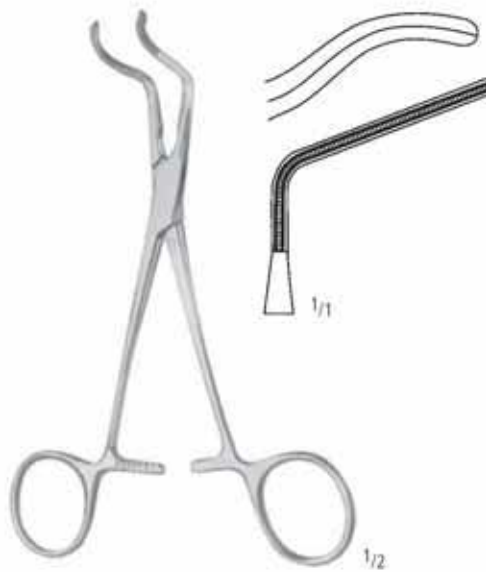

**SUBRAMANIAN-MINIATURE**  
 KK 651/15  
 15,5 cm/6"

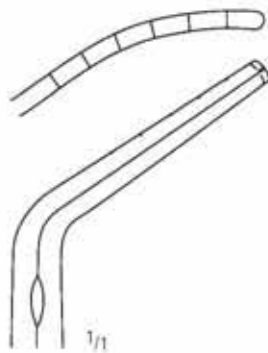

**SUBRAMANIAN**  
 KK 653/01  
 16,0 cm/6 1/4"

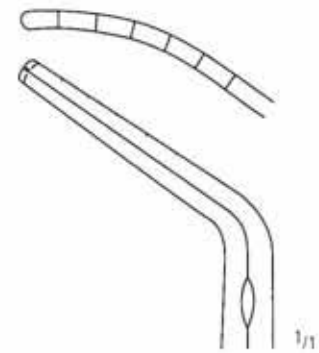

**SUBRAMANIAN**  
 KK 653/02  
 16,0 cm/6 1/4"

Bronchusklippen, Lungenfasszangen  
 Bronchus clamps, Lung grasping forceps  
 Pinzas clamps bronquiales y para pulmon  
 Pincas-clamps à bronches et à poumons  
 Pinze per bronchi, Pinze per polmoni



**PRICE-THOMAS**  
 KK 701/22  
 22,0 cm/8<sup>3</sup>/<sub>4</sub>"



KK 702/01

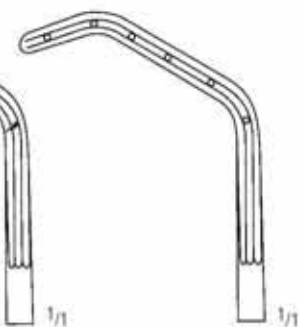

KK 702/02

**PRICE-THOMAS**  
 22,0 cm/8<sup>3</sup>/<sub>4</sub>"



**SEMB**  
 24,0 cm/9<sup>1</sup>/<sub>2</sub>"



KK 703/01

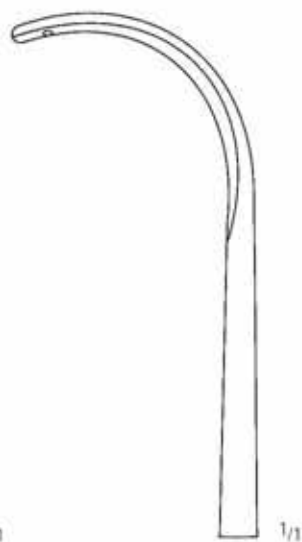

KK 703/02

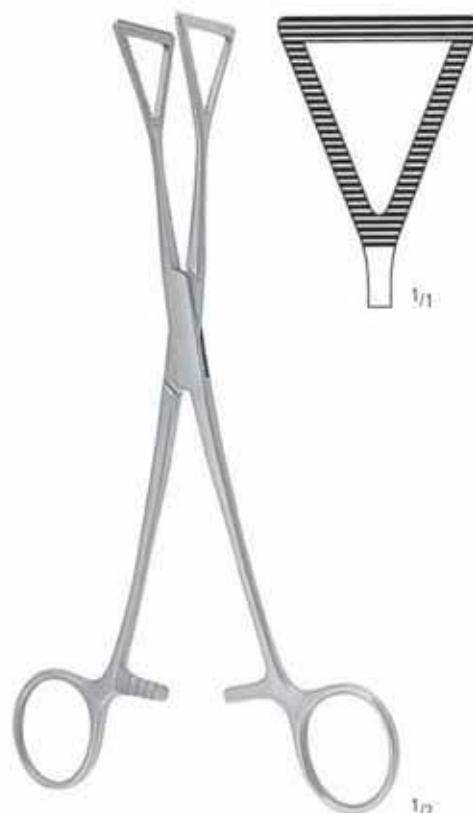

**LOVELACE**  
 KK 704/20  
 20,0 cm/8"



AA  
 AB  
 AC  
 AD  
 AE  
 AF  
 AK  
 AL  
 AO  
 KA  
 KK  
 X

Vena-Cava Klemmen  
 Vena-Cava Forceps  
 Clamps Vena Cava  
 Pincés Vena Cava  
 Pinze Vena Cava



**SATINSKY**  
 26,0 cm/10<sup>1</sup>/<sub>2</sub>"

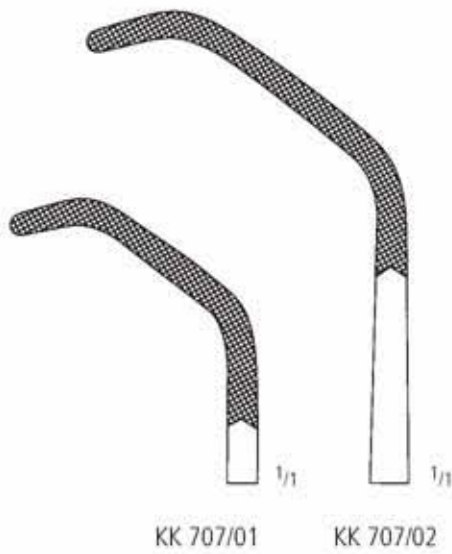

KK 707/01      KK 707/02



**BABY-SATINSKY**  
 KK 708/15  
 15,0 cm/6"



**HARKEN**  
 24,0 cm/9<sup>1</sup>/<sub>2</sub>"



KK 709/01  
 24,0 cm/9<sup>1</sup>/<sub>2</sub>"



KK 709/02  
 24,0 cm/9<sup>1</sup>/<sub>2</sub>"

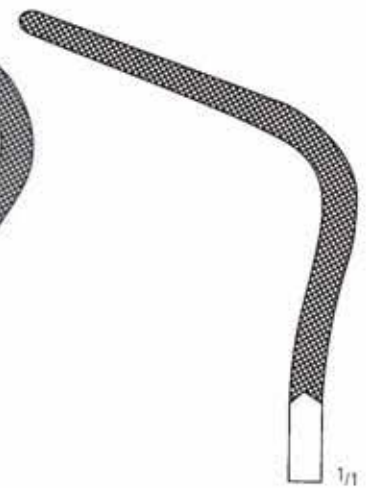

KK 709/03  
 24,0 cm/9<sup>1</sup>/<sub>2</sub>"

Dilatatoren, Tourniquet  
 Dilators, Tourniquets  
 Diladores, Torniquetes  
 Dilateurs, Tourniquets  
 Dilatori, Tornichetti

AA  
 AB  
 AC  
 AD  
 AE  
 AF  
 AG  
 AH  
 AI  
 AJ  
 AK  
 AL  
 AM  
 AN  
 AO  
 AP  
 AQ  
 AR  
 AS  
 AT  
 AU  
 AV  
 AW  
 AX  
**KK**  
 KY



**TUBBS**  
 KK 720/42

flexibel  
 flexible  
 flexibles  
 flessibili



**COOLEY**  
 KK 722/15



**RUMEL-BELMONT**  
 Ø 3,2 mm KK 730/32  
 Ø 6,4 mm KK 730/64





THORAKOSKOPIE  
THORACOSCOPY  
TORACOSCOPIA  
TORACOSCOPIE  
TORACOSCOPIA

X

nopa<sup>®</sup> instruments

Weitere Endoskopie-Instrumente finden Sie in unserem Katalog "Endoskopie".

For further endoscopic instruments kindly refer to our catalogue "Endoscopy".

Para instrumental de endoscopia adicional, por favor consulte nuestro catálogo de "Endoscopia".

Pour des instruments d'endoscopie supplémentaires, consultez notre catalogue "Endoscopie".

Per gli altri strumenti endoscopia, consultare il nostro catalogo "Endoscopia".





>> Optiken • Telescopes • Ópticas • Optiques • Ottiche

304–305

1

>> Instrumente für Laparoskopie / Thorax • Instruments for Laparoscopy / Thorax  
Instrumentos para Laparoscopia / Tórax • Instruments pour Laparoscopie / Thorax  
Strumenti per Laparoscopia / Torace

306–313

3

>> Elektroden / Saugen / Spülen / Kanülen / Trokare • Electrodes / Suction / Irrigation / Cannulae /  
Trocars • Electrodos / Succión / Irrigación / Agujas / Trócares • Electrodes / Aspiration / Irrigation /  
Canules / Trocarts • Elettrodi / Aspirazione / Irrigazione / Aghi speciali / Tre quarti

314–325

5

>> HF-Zubehör • HF-accessories • AF-accesorios • HF-accessoires • AF-accessori

326–331

7

>> Kaltlichtquellen, Kameras • Cold light sources, cameras • Fuentes de luz fría, cámaras  
Sources à lumière froide, caméras • Sorgente luce fredda, macchine fotografiche

332–341

18

>> Verschiedenes • Various items • Artículos diversos • Articles divers • Articoli diversi

342–343

22

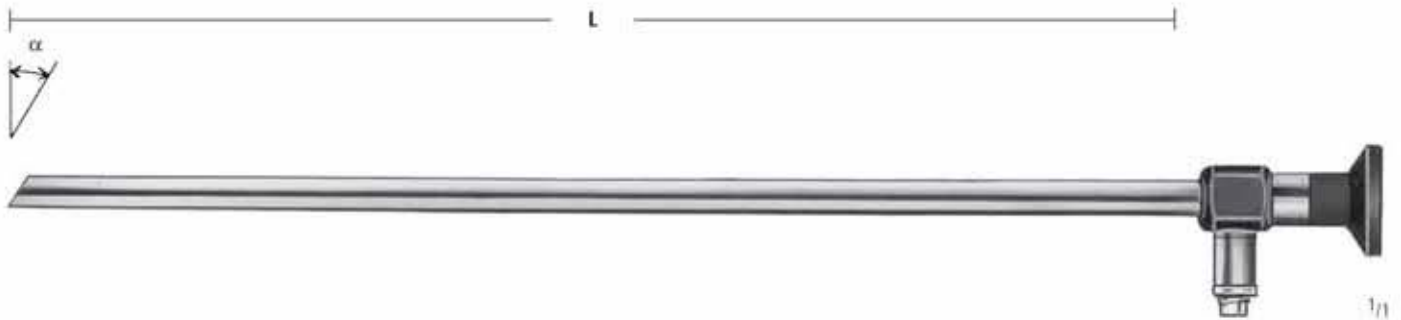

Ø mm	$\alpha = 0^\circ$	$\alpha = 30^\circ$	L
5,0	XP 720/50	XP 720/53	336 mm
6,5	XP 720/60	XP 720/63	336 mm
8,0	XP 721/80	XP 721/83	340 mm
10,0	XP 722/90	XP 722/93	344 mm

>> autoklavierbar  
autoclavable

>> mit Anschluss für  
with adaptors for

Storz  
Wolf  
ACMI

Thorakoskopie - Bronchoskopie  
 Thoracoscopy - Bronchoscopy  
 Torascoscopia - Bronquioscopia  
 Thorascoscopia - Bronchoscopy  
 Torascoscopia - Broncoscopia

1  
3  
5  
7  
18  
22



Ø mm	$\alpha = 0^\circ$	$\alpha = 30^\circ$
10,0	XP 728/10	XP 728/13

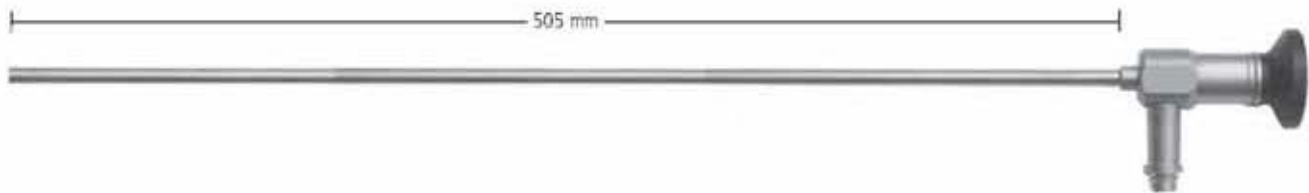

Ø mm	$\alpha = 0^\circ$	$\alpha = 30^\circ$
5,5	XP 729/50	XP 729/53

>> autoklavierbar  
autoclavable

>> mit Anschluss für  
with adaptors for

Storz  
Wolf  
ACMI



# easyClean®

Ø 5,0 mm, 10,0 mm, 2-teilig / 2-piece

## THORAX



XM 010/00



XM 014/00



XM 016/00

Bestellinformation: Bestellen Sie bitte Griff und Arbeitseinsatz  
Ordering information: Please order handle and working tip







Scharfe Präparation, Faszangen  
 Sharp Dissection, Grasping Forceps  
 Disección punta, Pinzas de aprehensión  
 Dissection tranchant, Pinces à Préhension  
 Dissezione tagliente, Pinze da presa

easyClean<sup>®</sup>

Ø 5,0 mm, 10,0 mm, 2-teilig / 2-piece

THORAX

Bestellinformation: Bestellen Sie bitte Griff und Arbeitseinsatz  
 Ordering information: Please order handle and working tip

		36,0 cm/14"
	Ø 5,0 mm	XM 300/01
METZENBAUM		
		
	Ø 5,0 mm	XM 300/02
PERITONEUM SCHERE PERITONEAL SCISSORS		
		
	Ø 5,0 mm	XM 300/03
MIKROSCHERE MICRO SCISSORS		
		
	Ø 5,0 mm	XM 300/04
LÖFFEL SPOON		
		
	Ø 5,0 mm	XM 300/10
STARKE GREIFZANGE STRONG GRASPER		
		
	Ø 5,0 mm	XM 300/11
GREIFZANGE GRASPING FORCEPS		

1  
3  
5  
7  
18  
22





Fasszangen  
Grasping forceps  
Pinzas de aprehensión  
Pinces à préhension  
Pinze da presa

easyClean<sup>®</sup>

Ø 5,0 mm, 10,0 mm, 2-teilig / 2-piece

THORAX

Bestellinformation: Bestellen Sie bitte Griff und Arbeitseinsatz  
Ordering information: Please order handle and working tip

		36,0 cm/14"
	Ø 5,0 mm	XM 300/12
McKERNAN		
		
	Ø 5,0 mm	XM 300/13
GEZAHNTER GREIFER KOBRA TOOTHED GRASPER COBRA		
		
	Ø 5,0 mm	XM 300/14
FASSZANGE GEFENSTERT GRASPING FORCEPS FENSTERED		
		
	Ø 5,0 mm	XM 300/15
BABCOCK - ALLIS		
		
	Ø 10,0 mm	XM 300/16
DUVAL		

Fasszangen  
Grasping Forceps  
Pinzas de aprehensi3n  
Pinces 3 pr3hension  
Pinze da presa

easyClean<sup>®</sup>

Ø 5,0 mm, 10,0 mm, 2-teilig / 2-piece

THORAX

Bestellinformation: Bestellen Sie bitte Griff und Arbeitseinsatz  
Ordering information: Please order handle and working tip



36,0 cm/14"

Ø 10,0 mm

XM 300/17

KOCHER KLAMMERZANGE  
KOCHER CLAMPING FORCEPS



Ø 5,0 mm

XM 300/18

ATRAUMATISCHER GREIFER  
ATRAUMATIC GRASPER



Ø 5,0 mm

XM 300/19

MARYLAND







1  
3  
5  
7  
18  
22

Scharfe Präparation, Fasszangen  
 Sharp Dissection, Grasping Forceps  
 Disección punta, Pinzas de aprehensión  
 Dissection tranchant, Pinces à Préhension  
 Dissezione tagliente, Pinze da presa

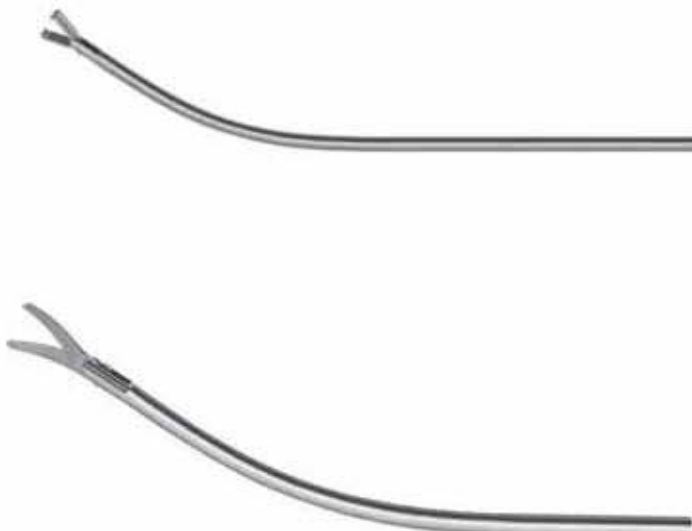
Ø 5,0 mm, 10,0 mm, 1-teilig / 1-piece

# THORAX



	<p>METZENBAUM</p>	<p>Ø 5,0 mm</p>	<p>36,0 cm/14"                  XM 301/01</p>
	<p>PERITONEUM SCHERE                  PERITONEAL SCISSORS</p>	<p>Ø 5,0 mm</p>	<p>XM 301/02</p>
	<p>MIKROSCHERE                  MICRO SCISSORS</p>	<p>Ø 5,0 mm</p>	<p>XM 301/03</p>
	<p>LÖFFEL                  SPOON</p>	<p>Ø 5,0 mm</p>	<p>XM 301/04</p>
	<p>STARKE GREIFZANGE                  STRONG GRASPER</p>	<p>Ø 5,0 mm</p>	<p>XM 301/10</p>
	<p>GREIFZANGE                  GRASPING FORCEPS</p>	<p>Ø 5,0 mm</p>	<p>XM 301/11</p>

Fasszangen  
Grasping Forceps  
Pinzas de aprehensión  
Pinces à préhension  
Pinze da presa

Ø 5,0 mm, 10,0 mm, 1-teilig / 1-piece

THORAX

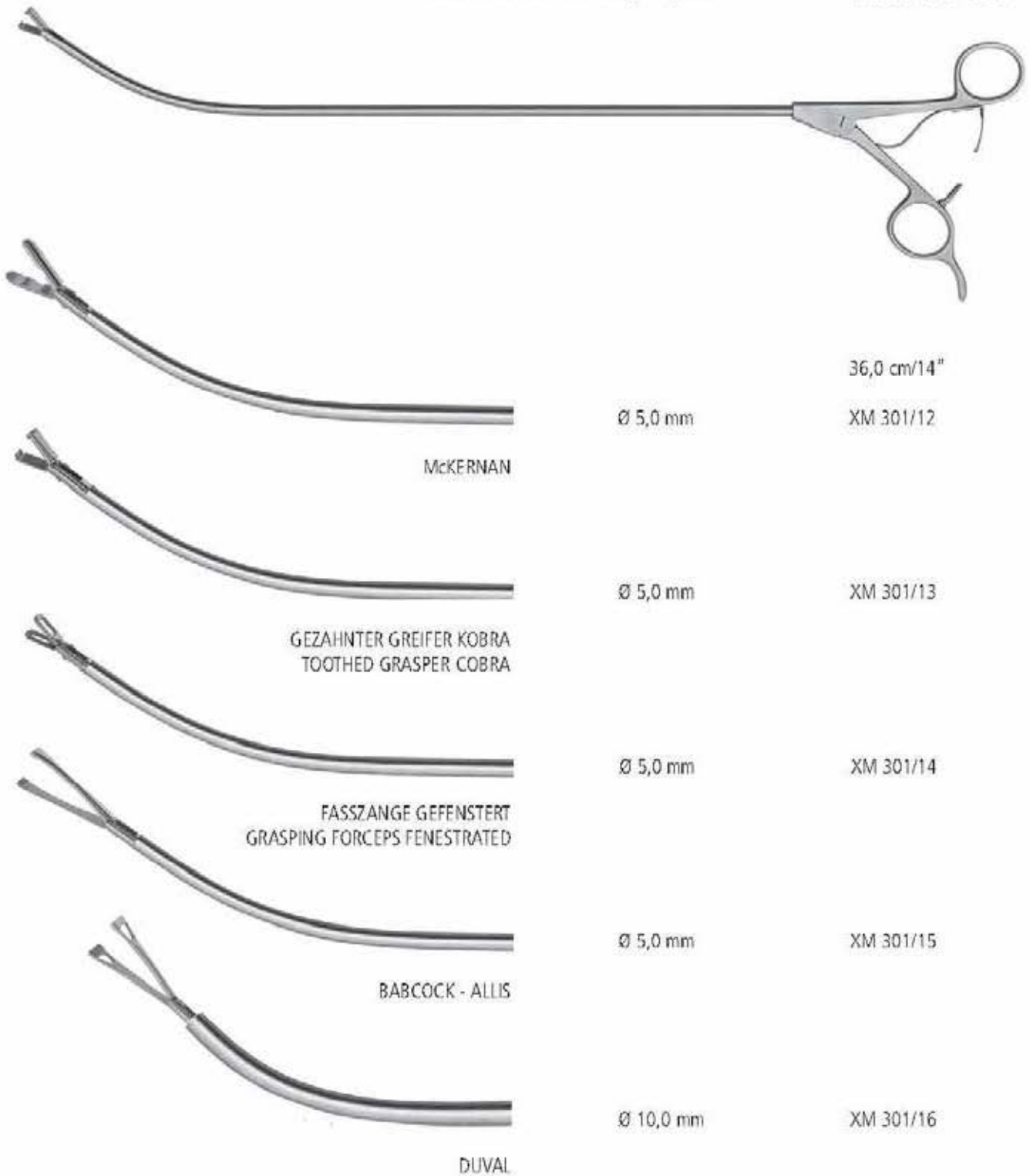

36,0 cm/14"

Ø 5,0 mm

XM 301/12

McKERNAN

Ø 5,0 mm

XM 301/13

GEZAHNTER GREIFER KOBRA  
TOOTHED GRASPER COBRA

Ø 5,0 mm

XM 301/14

FASSZANGE GEFENSTERT  
GRASPING FORCEPS FENESTRATED

Ø 5,0 mm

XM 301/15

BABCOCK - ALLIS

Ø 10,0 mm

XM 301/16

DUVAL

1  
3  
5  
7  
18  
22



Fasszangen  
Grasping Forceps  
Pinzas de aprehensión  
Pinces à préhension  
Pinze da presa

Ø 5,0 mm, 10,0 mm, 1-teilig / 1-piece

# THORAX

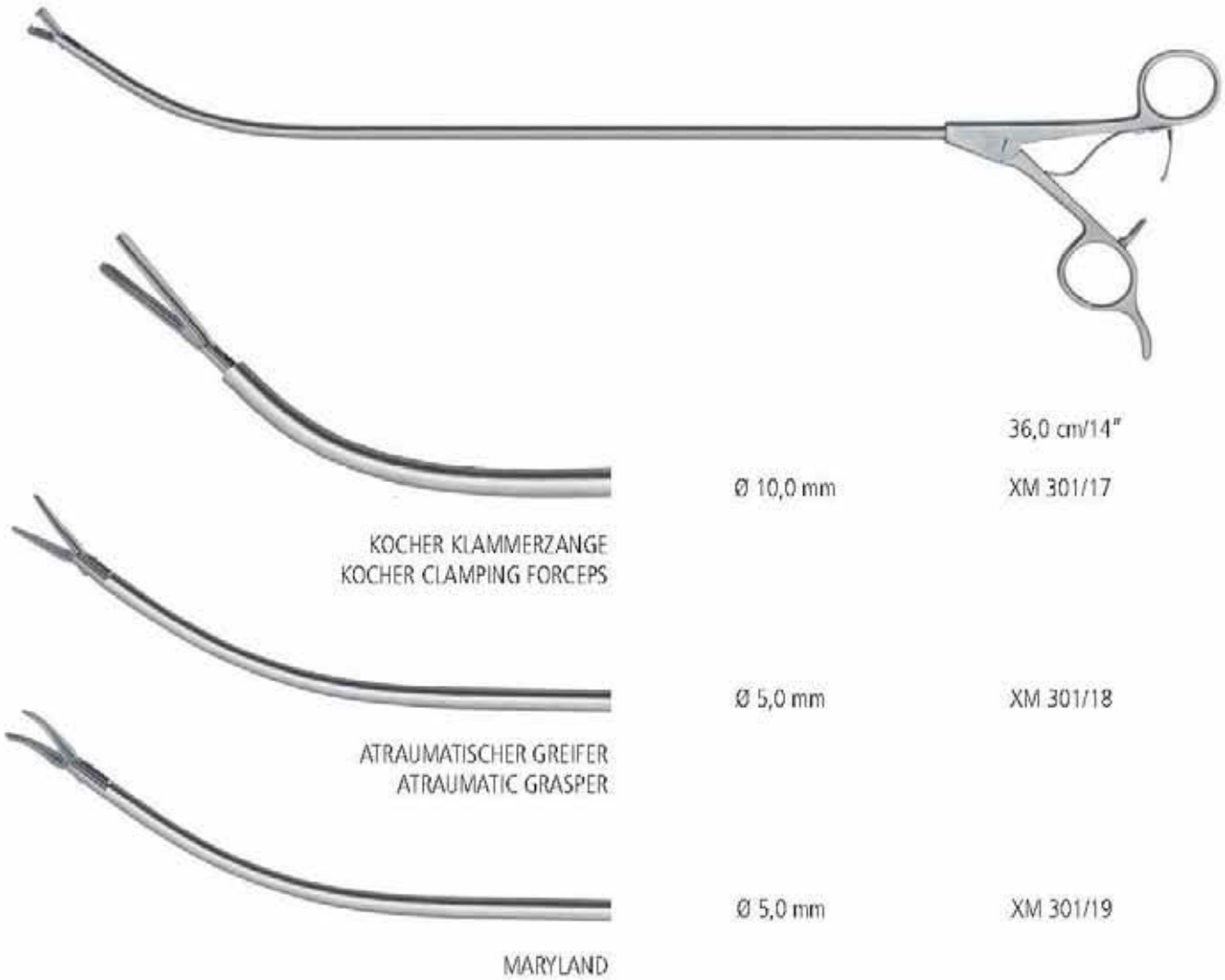

36,0 cm/14"

Ø 10,0 mm

XM 301/17

KOCHER KLAMMERZANGE  
KOCHER CLAMPING FORCEPS

Ø 5,0 mm

XM 301/18

ATRAUMATISCHER GREIFER  
ATRAUMATIC GRASPER

Ø 5,0 mm

XM 301/19

MARYLAND

ENDOSKOPIE ENDOSCOPY ENDOSCOPIA ENDOSCOPIE ENDOSCOPIA

Retraktoren  
Retractors  
Separadores  
Ecarteurs  
Divaricatori

1  
3  
5  
7  
18  
22

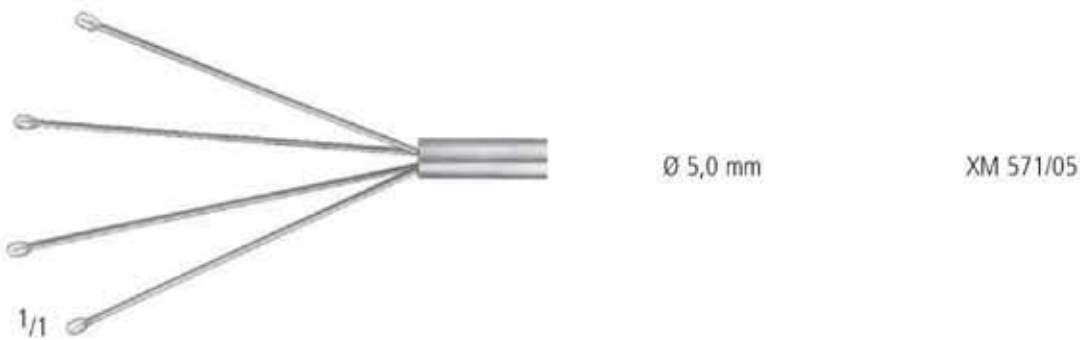
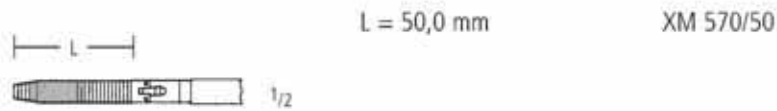
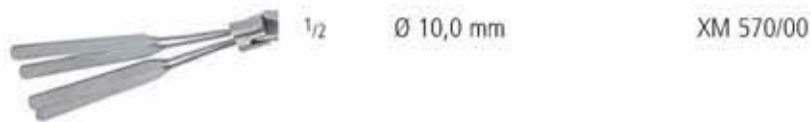

Elektroden mit Absaugung  
 Electrodes with suction tube  
 Electrodo con tubo de succión  
 Electrodes avec canule d'aspiration  
 Elettrodi con tubo d'aspirazione

nopa econom

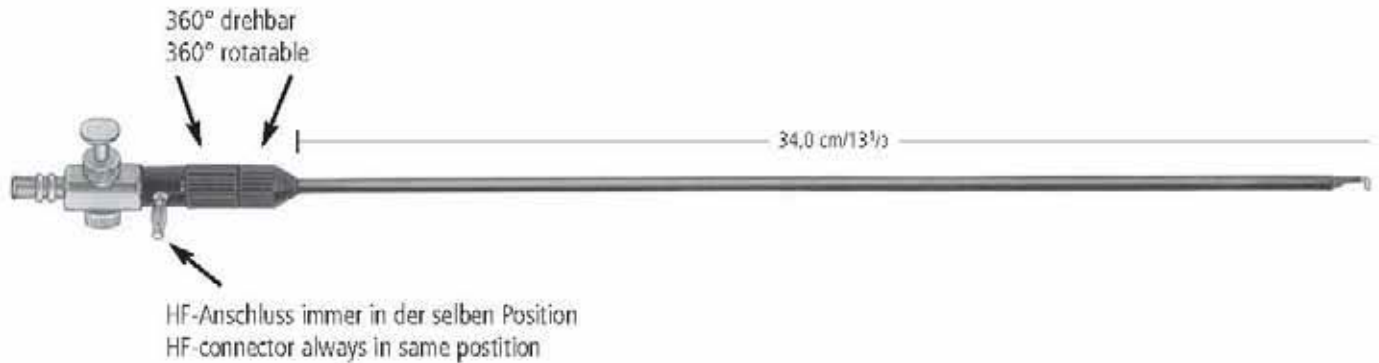

XK 546/00



XK 547/00



XK 548/00

perfekte Reinigung  
 perfect cleaning



Ø 5,0 mm  
 XK 549/01



Ø 5,0 mm  
 XK 549/02



Ø 5,0 mm  
 XK 549/03



Ø 5,0 mm  
 XK 549/04



**nopa-econom** Elektroden sind durch LUER-LOCK Kupplung leicht auseinandernehmbar. Trotz Verwendung von hochwertigstem Isoliermaterial werden Elektrodenschäfte immer wieder durch unsachgemäße Handhabung oder Reinigung beschädigt. Das nopa System garantiert schnelles und enorm kostengünstiges Auswechseln. Durch unsere Kombinationsmöglichkeiten ergeben sich bereits bei der Grundausstattung erhebliche wirtschaftliche Vorteile.

**nopa-econom** electrodes are easy to take apart by means of a LUER-LOCK coupling (connection). Although our electrode shafts are coated with superb insulation material, the insulation is very often damaged due to improper handling or cleaning procedures. The nopa system guarantees a fast, reliable and inexpensive exchange of shafts. The combination possibilities offer enormous cost advantages even for a basic instrument set.

Elektroden mit Absaugung  
 Electrodes with suction tube  
 Electrodo con tubo de succión  
 Electrodes avec canule d'aspiration  
 Elettrodi con tubo d'aspirazione



Ø 5,0 mm XK 550/01



Ø 5,0 mm XK 550/02



Ø 5,0 mm XK 550/03



Ø 5,0 mm XK 550/04



Ø 5,0 mm XK 550/05

1  
3  
5  
7  
18  
22

5 ENDOSKOPIE ENDOSCOPY ENDOSCOPIA ENDOSCOPIE ENDOSCOPIA

Elektroden mit Absaugung  
 Electrodes with suction tube  
 Electrodoes con tubo de succión  
 Electrodes avec canule d'aspiration  
 Elettrodi con tubo d'aspirazione

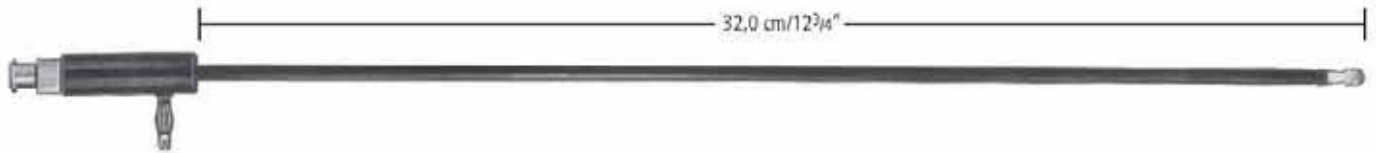

Ø 5,0 mm XK 554/01



Ø 5,0 mm XK 554/02



Ø 5,0 mm XK 554/03



Ø 5,0 mm XK 554/04



Ø 5,0 mm XK 554/05

ENDOSKOPIE ENDOSCOPY ENDOSCOPIA ENDOSCOPIE ENDOSCOPIA

Elektroden ohne Absaugung  
 Electrodes without suction tube  
 Electrodoes sin tubo de succión  
 Electrodes sans canule d'aspiration  
 Elettrodi senza tubo d'aspirazione



Ø 5,0 mm XK 556/01



Ø 5,0 mm XK 556/02



Ø 5,0 mm XK 556/03



Ø 5,0 mm XK 556/04



Ø 5,0 mm XK 556/05

1  
3  
5  
7  
18  
22



5 ENDOSKOPIE ENDOSCOPY ENDOSCOPIA ENDOSCOPIE ENDOSCOPIA

Saug- und Spülrohre, Punktionskanülen  
 Suction and irrigation tubes, Puncture needles  
 Cánulas de aspiración, Agujas para punción  
 Canules d'aspiration, Aiguilles pour ponction  
 Cannule per aspirazione, Aghi per puntura



Saug- und Spülrohre  
Suction and irrigation tubes  
Cánulas de aspiración  
Canules d'aspiration  
Cannule per aspirazione



Saug und Spül Pistolenhandgriff  
Suction and irrigation handle

XK 663/01

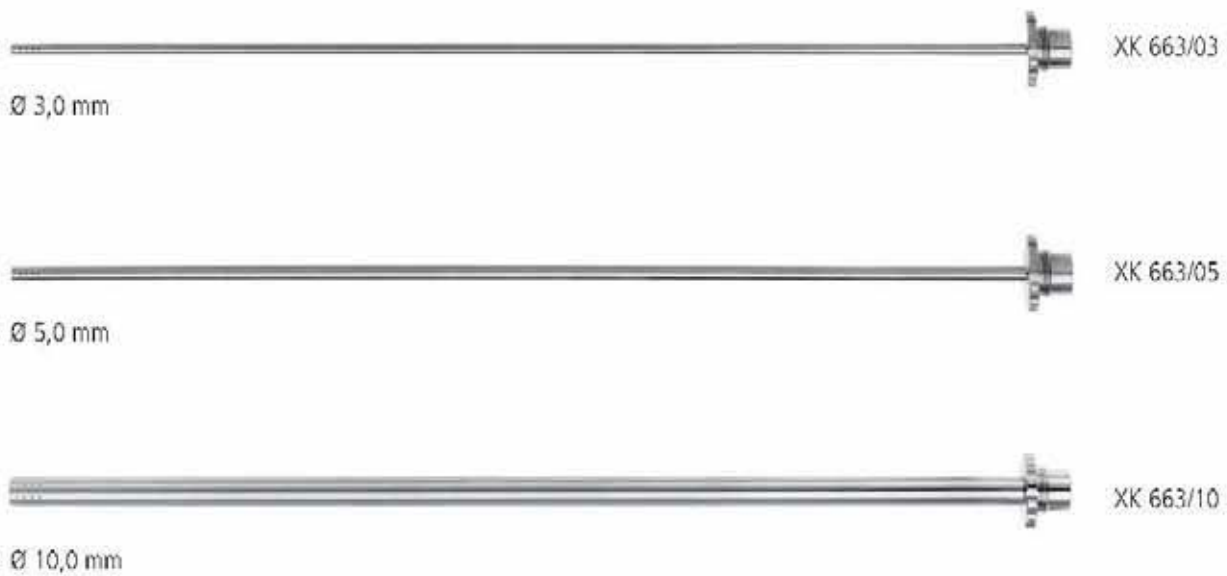

XK 663/00 = XK 663/01  
XK 663/03  
XK 663/05  
XK 663/10

1  
3  
5  
7  
18  
22

Elektroden mit Absaugung  
 Electrodes with suction tube  
 Electrodo con tubo de succión  
 Electrodes avec canule d'aspiration  
 Elettrodi con tubo d'aspirazione



Saug und Spül Pistolenhandgriff  
 Suction and irrigation handle

XK 663/01



Adapter für Elektroden  
 Adaptor for electrodes

XK 663/20



Ø 5,0 mm XK 549/01



Ø 5,0 mm XK 549/02



Ø 5,0 mm XK 549/03



Ø 5,0 mm XK 549/04

**nopa-econom** Elektroden sind durch LUER-LOCK Kupplung leicht auseinandernehmbar. Trotz Verwendung von hochwertigstem Isoliermaterial werden Elektrodenschäfte immer wieder durch unsachgemäße Handhabung oder Reinigung beschädigt. Das nopa System garantiert schnelles und enorm kostengünstiges Auswechseln. Durch unsere Kombinationsmöglichkeiten ergeben sich bereits bei der Grundausstattung erhebliche wirtschaftliche Vorteile.

**nopa-econom** electrodes are easy to take apart by means of a LUER-LOCK coupling (connection). Although our electrode shafts are coated with superb insulation material, the insulation is very often damaged due to improper handling or cleaning procedures. The nopa system guarantees a fast, reliable and inexpensive exchange of shafts. The combination possibilities offer enormous cost advantages even for a basic instrument set.

Trokarhülsen und Trokare  
Trocar sleeves and trocars  
Camisa para trocares y trocares  
Trocards à manche et trocards  
Manicotti trequarti e trequarti

## THORAX

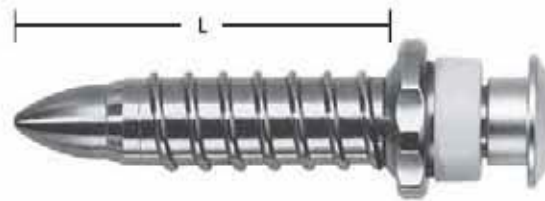

Satz

Set

Ø 6,0 mm	L=5,0 cm/2"	XK 645/06
Ø 11,0 mm	L=5,0 cm/2"	XK 645/11
Ø 13,0 mm	L=5,0 cm/2"	XK 645/13

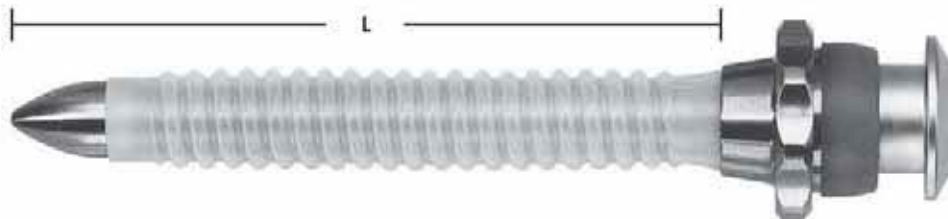

Satz

Set

Ø 6,0 mm	L=7,0 cm/2 <sup>3</sup> / <sub>4</sub> "	XK 647/06
Ø 6,0 mm	L=10,0 cm/4"	XK 647/16
Ø 11,0 mm	L=7,0 cm/2 <sup>3</sup> / <sub>4</sub> "	XK 648/11
Ø 11,0 mm	L=10,0 cm/4"	XK 648/21

Flexible Kunststoffrohre, Verpackungseinheit 5 Stück

Flexible plastic tubes, packing unit 5 pieces

Ø 6,0 mm	L=7,0 cm/2 <sup>3</sup> / <sub>4</sub> "	XK 647/26
Ø 6,0 mm	L=10,0 cm/4"	XK 647/36
Ø 11,0 mm	L=7,0 cm/2 <sup>3</sup> / <sub>4</sub> "	XK 648/31
Ø 11,0 mm	L=10,0 cm/4"	XK 648/41

Trokarhülsen und Trokare  
 Trocar sleeves and trocars  
 Camisa para trocares y trocares  
 Trocards à manche et trocards  
 Manicotti trequarti e trequarti



Satz

Set

Ø	3,5 mm	XK 650/03
Ø	5,0 mm	XK 650/05
Ø	5,5 mm	XK 650/06
Ø	10,0 mm	XK 650/10
Ø	11,0 mm	XK 650/11
Ø	12,5 mm	XK 650/12

## ENDOSKOPIE ENDOSCOPY ENDOSCOPIA ENDOSCOPIE ENDOSCOPIA

Trokarhülsen und Trokare  
 Trocar sleeves and trocars  
 Camisa para trocares y trocares  
 Trocards à manche et trocards  
 Manicotti trequarti e trequarti

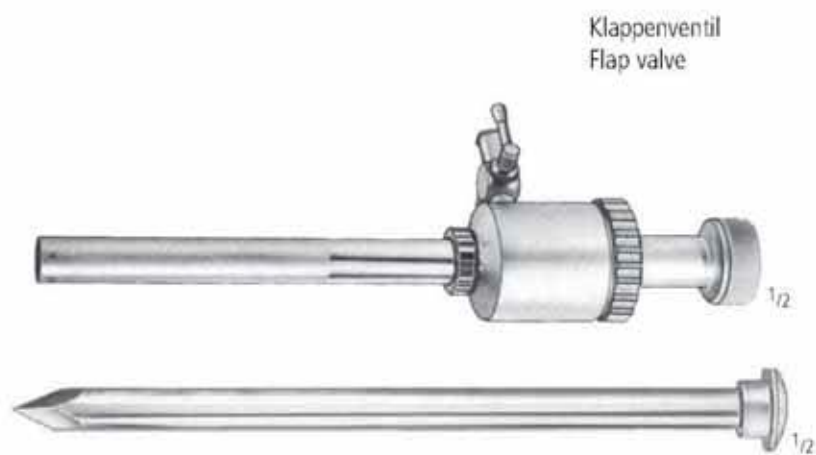

Satz		
Set		
Ø	3,5 mm	XK 652/03
Ø	5,0 mm	XK 652/05
Ø	5,5 mm	XK 652/06
Ø	10,0 mm	XK 652/10
Ø	11,0 mm	XK 652/11
Ø	12,5 mm	XK 652/12

1

3

5

7

18

22



Trokaraufsätze, Reduzierstücke  
 Trocar stop with thread, Reducers  
 Tope de trocar con cuerda, Reductores  
 Stop trocards, Reducteurs  
 Inserto per trequarti, Riduttore



Ø 5,5 mm	XK 700/05
Ø 11,0 mm	XK 700/11



Ø 5,0 mm	XK 702/05
Ø 5,5 mm	XK 702/06
Ø 10,0 mm	XK 702/10
Ø 11,0 mm	XK 702/11
Ø 12,0 mm	XK 702/12



Ø 10,0 mm	→	5,5 mm	XK 706/01
Ø 11,0 mm	→	5,5 mm	XK 706/02
Ø 12,5 mm	→	5,5 mm	XK 706/03
Ø 12,5 mm	→	10,0 mm	XK 706/04

ENDOSKOPIE ENDOSCOPY ENDOSCOPIA ENDOSCOPIE ENDOSCOPIA

Trokarhülsen und Trokare  
Trocar sleeves and trocars  
Camisa para trocares y trocares  
Trocards à manche et trocards  
Manicotti trequarti e trequarti



- Ø 5,0 mm XK 750/05
- Ø 8,0 mm XK 750/08
- Ø 10,0 mm XK 750/10
- Ø 11,0 mm XK 750/11
- Ø 12,5 mm XK 750/12



- Ø 5,0 mm XK 751/05
- Ø 12,5 mm XK 751/12
- Ø 15,0 mm XK 751/15
- Ø 20,0 mm XK 751/20



- |           |           |           |           |
|-----------|-----------|-----------|-----------|
|           |           |           |           |
| Ø 3,5 mm  | XK 760/03 | XK 761/03 | XK 762/03 |
| Ø 5,0 mm  | XK 760/05 | XK 761/05 | XK 762/05 |
| Ø 5,5 mm  | XK 760/06 | XK 761/06 | XK 762/06 |
| Ø 8,0 mm  | XK 760/08 | XK 761/08 | XK 762/08 |
| Ø 10,0 mm | XK 760/10 | XK 761/10 | XK 762/10 |
| Ø 11,0 mm | XK 760/11 | XK 761/11 | XK 762/11 |
| Ø 12,5 mm | XK 760/12 | XK 761/12 | XK 762/12 |
| Ø 15,0 mm | XK 760/15 | XK 761/15 | XK 762/15 |
| Ø 20,0 mm | XK 760/20 | XK 761/20 | XK 762/20 |



- Ø 5,0 mm XK 763/05
- Ø 5,5 mm XK 763/06
- Ø 10,0 mm XK 763/10
- Ø 11,0 mm XK 763/11
- Ø 12,5 mm XK 763/12



- Ø 5,0 mm XK 765/05
- Ø 8,0 mm XK 765/08
- Ø 10,0 mm XK 765/10
- Ø 11,0 mm XK 765/11
- Ø 12,5 mm
- Ø 15,0 mm
- Ø 20,0 mm



- XK 766/05
- XK 766/08
- XK 766/10
- XK 766/11
- XK 766/12



- XK 766/15
- XK 766/20



- XK 767/05
- XK 767/08
- XK 767/10
- XK 767/11
- XK 767/12
- XK 767/15
- XK 767/20

1  
3  
5  
7  
18  
22

Anschlusskabel  
 Connection cords  
 Cables de conexión  
 Câbles de raccordement  
 Cavi da connessione

monopolar

bipolar



MARTIN / BERCHTOLD

300 cm	XR 827/03	XR 828/03	XR 830/03
500 cm	XR 827/05	XR 828/05	XR 830/05

monopolar

bipolar

monopolar

bipolar



ERBE

300 cm XR 831/03  
 500 cm XR 831/05  
 (ACC/ACC)

ERBE

XR 831/13  
 XR 831/15  
 (T Serie)

ERBE/SELECT

XR 832/03  
 XR 832/05

ERBE

XR 833/03  
 XR 833/05

VALLEYLAB

XR 834/03  
 XR 834/05  
 (in D nicht zulässig  
 nach MedGV)

Elektroden  
Electrodes  
Electrodos  
Electrodes  
Elettrodi

universal



XR 841/01



XR 841/02



XR 841/03



XR 841/04



XR 841/05



XR 841/06



XR 841/07



XR 841/08



XR 841/09



XR 841/10



XR 841/11



XR 841/12

1  
3  
5  
7  
18  
22

Elektroden  
Electrodes  
Electrodos  
Electrodes  
Elettrodi

universal



XR 843/01



XR 843/02



XR 843/03



XR 843/04



XR 843/05



XR 843/06



XR 843/07



XR 843/08



XR 843/09





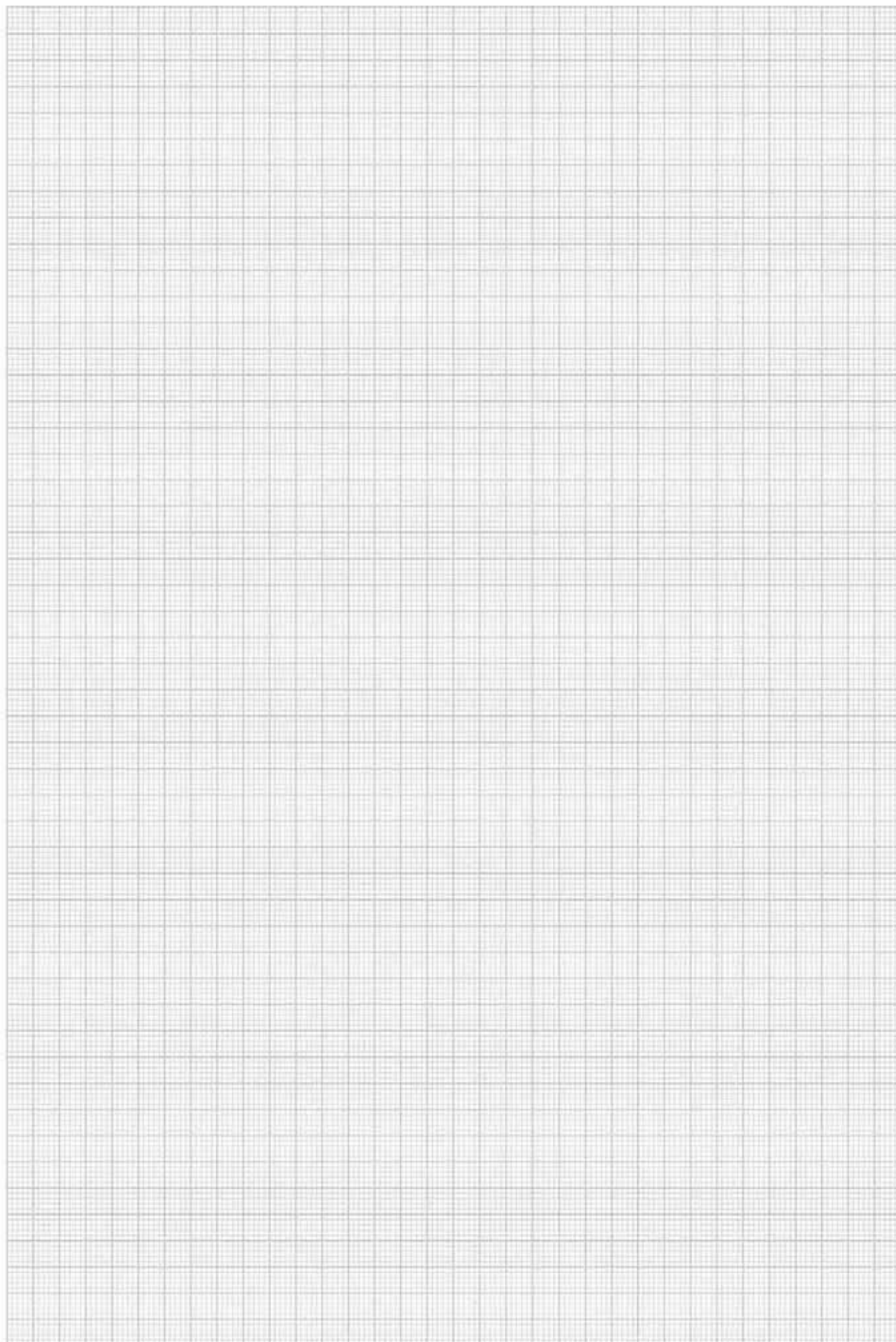

ENDOSKOPIE ENDOSCOPY ENDOSCOPIA ENDOSCOPIE ENDOSCOPIA

Bi-Koagulations-Pinzetten  
 Bi-Coagulation-Forceps  
 Pinzas para la Bi-Coagulación  
 Pince pour la Bi-Coagulation  
 Pinze per la Bi-Coagulazione



16,0 cm/6 1/4"	XR 890/16 A	XR 891/16 C	XR 894/16 C		
16,0 cm/6 1/4"	XR 890/16 C	XR 891/16 D	XR 894/16 D		
16,0 cm/6 1/4"	XR 890/16 E	XR 891/16 E	XR 894/16 E		
20,0 cm/8"	XR 890/20 A	XR 891/20 A	XR 894/20 A		
20,0 cm/8"	XR 890/20 C	XR 891/20 C	XR 894/20 C	XR 895/20 C	XR 896/20 C
20,0 cm/8"	XR 890/20 E	XR 891/20 F	XR 894/20 E		
20,0 cm/8"			XR 894/20 F		
22,0 cm/8 3/4"	XR 890/22 A	XR 891/22 C	XR 894/22 D		
22,0 cm/8 3/4"	XR 890/22 C		XR 894/22 E	XR 895/22 C	XR 896/22 C

A=2,0 mm

C=1,0 mm



D=0,5 mm

E=Nadel

F=Profil



11,0 cm/4 1/3"	XR 898/11 D	XR 899/11 D
11,0 cm/4 1/3"	XR 898/11 E	XR 899/11 E

Kaltlichtkabel  
 Fibre optic cable  
 Cable fibra óptica  
 Câble fibre optique  
 Cavo fibra ottica



XT 035/18	Ø 3,5 mm, 180 cm
XT 035/23	Ø 3,5 mm, 230 cm
XT 035/30	Ø 3,5 mm, 300 cm
XT 045/18	Ø 4,5 mm, 180 cm
XT 045/23	Ø 4,5 mm, 230 cm
XT 045/30	Ø 4,5 mm, 300 cm
XT 060/18	Ø 6,0 mm, 180 cm
XT 060/23	Ø 6,0 mm, 230 cm
XT 060/30	Ø 6,0 mm, 300 cm

### Kaltlicht-Grundkabel Basic fibre optic cable

- >> **Zusätzliche Isolierung**
- >> **Metallspirale**
- >> **Silikonmantel**
- >> **Sterilisierbar**
- >> **48-Stunden Reparatur-Service**

- >> **Additionally insulated**
- >> **Metal spiral**
- >> **Silicon tube**
- >> **Autoclavable**
- >> **48-hour repair-service**

Adapter  
Adapter  
Adaptador  
Adaptateur  
Adattatore

**Projektor-Seite**  
**Projector side**

**Endoskop-Seite**  
**Endoscope side**

XT 100/01



**STORZ**



XT 100/11

**STORZ/WINTER + IBE**  
**OLYMPUS/STRYKER**

XT 100/02



**WOLF/HENKE-SASS**



XT 100/12

**WOLF/HENKE-SASS**

XT 100/03



**ACM/HEINE**



XT 100/13

**ACM/HEINE**

XT 100/04



**WINTER + IBE**

XT 100/05



**OLYMPUS**

**Bestellinformation / Ordering information**

>> Bitte bestellen Sie Kaltlicht-  
grundkabel mit 2 Adaptern

>> Please order the basic fibre  
optic cable and two adapters

1  
3  
5  
7  
18  
22



Kaltlichtquellen  
Cold light sources  
Fuente de luz fría  
Source à lumière froide  
Sorgente luce fredda

## nopa<sup>®</sup> light halogen 2 x 250W future 100



XT 170/00 – 110 - 230 VAC

XT 169/00 – Ersatzlampe  
Spare bulb  
Bombilla de recambio  
Lampe de rechange  
Lampadina di ricambio

### nopa light halogen 2 x 250W

#### Beschreibung XT 170/00

Die nopalight halogen 2 x 250 W Lichtquelle kann bei allen Einsätzen angewendet werden, besonders dann, wenn eine starke Ausleuchtung oder eine Videoaufzeichnung notwendig ist.

Alle modernen Autoshutter-Videokameras werden mit ausreichender Lichtzufuhr versorgt. Die zweite Lampe wird als Reserve bei Lampendefekten oder Lampenausfall durch sofortiges Umschalten während den Einsätzen aktiviert.

Spezielle Wärmeschutzfilter sorgen für eine Schonung der Lichtleiter und eine optimale Lichtfiltrierung. Das Gerät ist MedGV-geprüft.

#### Technische Daten

Elektr. Versorgung:	100-240 VAC/50-60Hz Weltnetzteil
Farbtemperatur:	über 3500° K
Lichtregelung:	automatisch, stufenlos
Maße (B x H x T):	355 x 110 x 320 mm
Gewicht:	ca. 8,5 kg

#### Zubehör

Lampe XT 169/00: 250 Watt Halogen

### nopa light halogen 2 x 250W

#### Description XT 170/00

The nopalight halogen 2 x 250 W lightsource can be utilized in all procedures, especially if a strong illumination or video-monitoring is required.

All modern autoshutter-videocameras will be supplied with sufficient light-intensity, the second lamp serves as stand-by. Simply switch-over.

Special temperature-filters guarantee long life of light cables and optimal light output. The nopalight halogen 2 x 250 W lightsource is approved by MedGV.

#### Technical data

Power supply:	100-240 VAC/50-60Hz world power supply
Color temperature:	more than 3500° K
Light control:	automatic
Measurements (W x H x D):	355 x 110 x 320 mm
Weight:	approx. 8,5 kg

#### Accessories

Bulb XT 169/00: 250 Watt Halogen

Kaltlichtquellen  
Cold light sources  
Fuente de luz fria  
Source à lumière froide  
Sorgente luce fredda

# nopa<sup>®</sup> light halogen 2 x 250W

## future 100 duo

XT 171/00	–	110 - 230 VAC
XT 169/00	–	Ersatzlampe Spare bulb Bombilla de recambio Lampe de rechange Lampadina di ricambio



### nopa light halogen 2 x 250W

#### Beschreibung XT 171/00

Die nopalight halogen 2 x 250 W Lichtquelle kann bei allen Einsätzen angewendet werden, besonders dann, wenn eine starke Ausleuchtung oder eine Videoaufzeichnung notwendig ist.

Alle modernen Autoshutter-Videokameras werden mit ausreichender Lichtzufuhr versorgt. Zwei Lampen - zwei umschaltbare Ausgänge.

Spezielle Wärmeschutzfilter sorgen für eine Schonung der Lichtleiter und eine optimale Lichtfiltrierung. Das Gerät ist MedGV-geprüft.

#### Technische Daten

Elektr. Versorgung:	100-240VAC/50-60Hz Weltnetzteil
Farbtemperatur:	über 3500° K
Lichtregelung:	automatisch, stufenlos
Maße (B x H x T):	355 x 110 x 320 mm
Gewicht:	ca. 8,5 kg

#### Zubehör

Lampe XT 169/00:	250 Watt Halogen
------------------	------------------

### nopa light halogen 2 x 250W

#### Description XT 171/00

The nopalight halogen 2 x 250 W lightsource, can be utilized in all procedures, especially if a strong illumination or video-monitoring is required.

All modern autoshutter-videocameras will be supplied with sufficient light-intensity, the second lamp serves as stand-by. Two bulbs - two outlets switchable.

Special temperature-filters guarantee long life of light cables and optimal light output. The nopalight halogen 2 x 250 W lightsource is approved by MedGV.

#### Technical data

Power supply:	100-240VAC/50-60Hz world power supply
Color temperature:	more than 3500° K
Light control:	automatic
Measurements (W x H x D):	355 x 110 x 320 mm
Weight:	approx. 8,5 kg

#### Accessories

Bulb XT 169/00:	250 Watt Halogen
-----------------	------------------



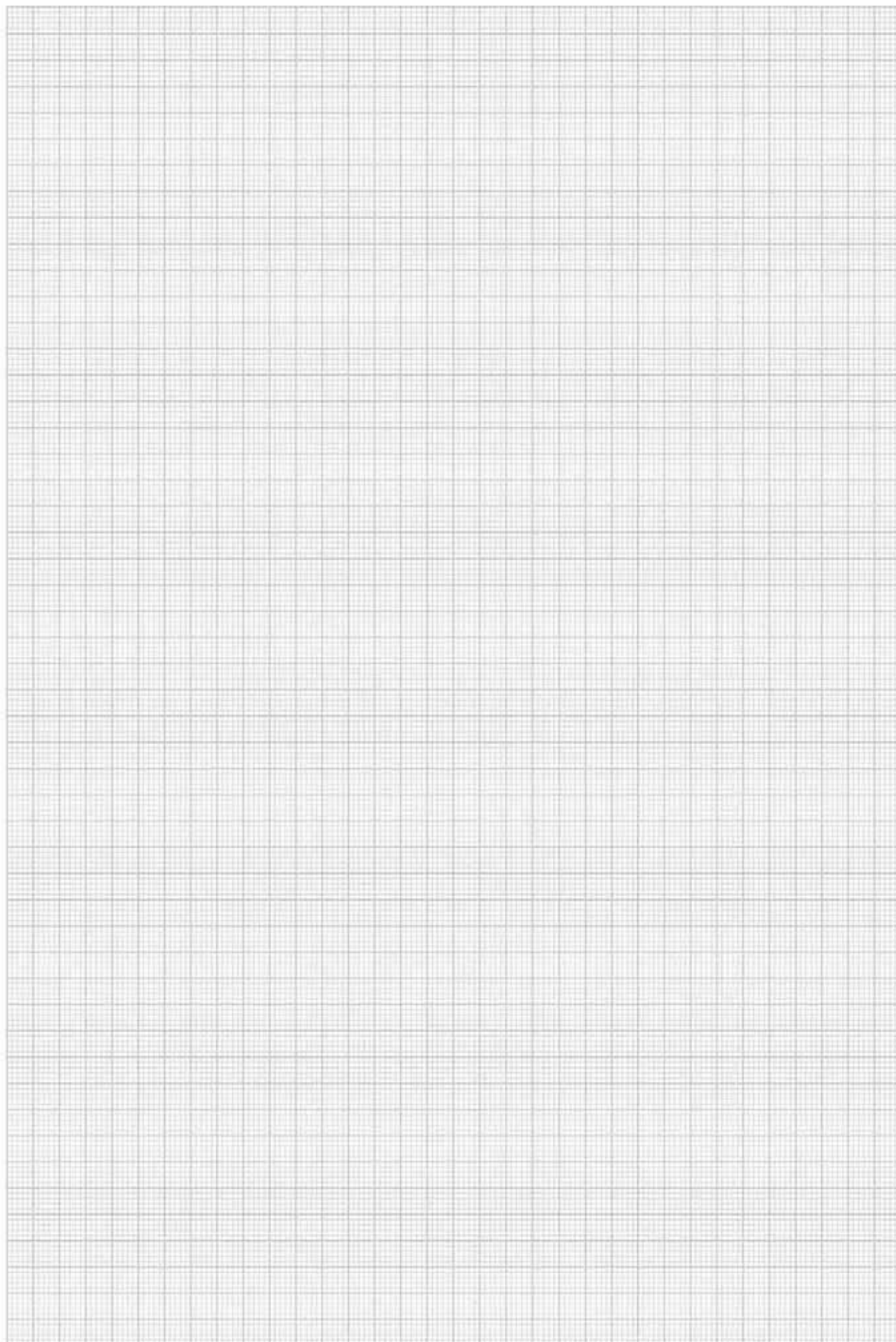

Kaltlichtquellen  
Cold light sources  
Fuente de luz fria  
Source à lumière froide  
Sorgente luce fredda

# nopa<sup>®</sup> light xenon

## future 200

### 180W

XT 205/00 – 110-230 VAC/50-60 Hz

XT 204/00 – Ersatzlampe  
Spare bulb  
Bombilla de recambio  
Lampe de rechange  
Lampadina di ricambio



## nopa light xenon 180W

### Beschreibung XT 205/00

Die nopalight xenon 180 Watt Lichtquelle kann bei allen Einsätzen angewendet werden, besonders dann, wenn eine starke Ausleuchtung oder eine Videoaufzeichnung notwendig ist.

Alle modernen Autoshutter-Videokameras werden mit ausreichender Lichtzufuhr versorgt. Die hohe Lichtausgangsleistung sorgt für absolut weißes Licht >5600°K und somit für detailgetreue Farbwiedergabe.

Unsere spezielle Lampenkonstruktion mit geringster Wärmeentwicklung führt zu absolut kaltem Licht und verhindert eine thermische Beschädigung der Lichtleiter.

Weitere Vorteile: Geringe Luftverwirbelungen, geringe Geräuschentwicklung, umweltfreundliche Lampe, einfachster Lampenwechsel.

### Technische Daten

Elektr. Versorgung: 110-230 VAC/50-60Hz  
Weltnetzteil

Farbtemperatur: > 5600° K

Maße (B x H x T): 355 x 110 x 320 mm

Gewicht: ca. 9,5 kg

### Zubehör

Lampe XT 204/00: 180 Watt Xenon

## nopa light xenon 180W

### Description XT 205/00

The nopalight xenon 180 watt light source can be used for all occasions particularly where strong illumination or a video recording is necessary.

All modern autoshutter videocameras are supplied with sufficient light. The high light output ensures absolute white light >5600° K and thus detail fidelity in colour reproduction.

Our special lamp construction which has the lowest of heat generation leads to absolute cold light and prevents thermal damage to the light conductor.

Further advantages are low air turbulence, low noise level, environmentally friendly lamp and very easy bulb replacement.

### Technical data

Power supply: 110-230 VAC/50-60Hz  
world power supply

Colour temperature: > 5600° K

Measurements (W x H x D): 355 x 110 x 320 mm

Weight: approx. 9,5 kg

### Accessories

Bulb XT 204/00: 180 Watt Xenon



Kaltlichtquellen  
Cold light sources  
Fuente de luz fría  
Source à lumière froide  
Sorgente luce fredda

# nopa light xenon

## future 300

### 300W



XT 210/00 – 110-230 VAC/50-60 Hz

XT 209/00 Ersatzlampe  
Spare bulb  
Bombilla de recambio  
Lampe de rechange  
Lampadina di ricambio

### nopa light xenon 300 W

#### Beschreibung XT 210/00

Die nopalight xenon 300 Watt Lichtquelle kann bei allen Einsätzen angewendet werden, besonders dann, wenn eine starke Ausleuchtung oder eine Videoaufzeichnung notwendig ist.

Alle modernen Autoshutter-Videokameras werden mit ausreichender Lichtzufuhr versorgt. Die hohe Lichtausgangsleistung sorgt für absolut weißes Licht >5600°K und somit für detailgetreue Farbwiedergabe.

Unsere spezielle Lampenkonstruktion mit geringster Wärmeentwicklung führt zu absolut kaltem Licht und verhindert eine thermische Beschädigung der Lichtleiter.

Weitere Vorteile: Geringe Luftverwirbelungen, geringe Geräuschentwicklung, umweltfreundliche Lampe, einfachster Lampenwechsel.

#### Technische Daten

Elektr. Versorgung: 110-230VAC/50-60Hz  
Weltnetzteil

Farbtemperatur: > 5600° K

Maße (B x H x T): 355 x 110 x 320 mm

Gewicht: ca. 11,5 kg

#### Zubehör

Lampe XT 209/00: 300 Watt Xenon

### nopa light xenon 300 W

#### Description XT 210/00

The nopalight xenon 300 watt light source can be used for all occasions particularly where strong illumination or a video recording is necessary.

All modern video camera automatic shutters are supplied with sufficient light. The high light output ensures absolute white light > 5600° K and thus detail fidelity in colour reproduction.

Our special lamp construction which has the lowest of heat generation leads to absolute cold light and prevents thermal damage to the light conductor.

Further advantages are low air turbulence, low noise level, environmentally friendly lamp and very easy bulb replacement.

#### Technical data

Power supply: 110-230VAC/50-60Hz  
world power supply

Colour temperature: > 5600° K

Measurements (W x H x D): 355 x 110 x 320 mm

Weight: approx. 11,5 kg

#### Accessories

Bulb XT 209/00: 300 Watt Xenon

# nopa<sup>®</sup>cam digital camera system

immersible  
soakable

<b>PAL/SECAM</b>		
XT 301/00	– XT 310/00	Netzkabel/mains cord
	XT 320/01	Kamerakopf inkl. Kabel 3,8 m, einlegbar camera head incl. cable 3,8 m, immersible
	XT 320/02	Kameraprozessor / camera control unit
	XT 344/02	Kabel/cable S-VHS
	XT 346/00	Kabel/cable BNC
<b>NTSC</b>		
XT 301/01	– XT 310/00	Netzkabel/mains cord
	XT 320/03	Kamerakopf inkl. Kabel 3,8 m, einlegbar camera head incl. cable 3,8 m, immersible
	XT 320/04	Kameraprozessor/camera control unit
	XT 344/00	Kabel/cable S-VHS
	XT 346/00	Kabel/cable BNC



## Beschreibung XT 301/00 / XT 301/01

nopa cam m ist die konsequente Weiterentwicklung unseres Kamerasystems. Neben allen früheren Funktionen wurden weitere Spezialfunktionen realisiert. Eine integrierte Steuerung externer Geräte (Videorecorder, Drucker) sowie die Lichtverstärkung können mittels zwei Funktionstasten direkt am Kamerakopf aktiviert werden.

Die Kamera ist mit digitaler Kontrast- und Farbsteuerung ausgestattet. Ebenfalls verfügt sie über einen digitalen anti-moiré Filter für den Gebrauch mit flexiblen Endoskopen.

Die Kamera arbeitet optimal mit starren wie auch flexiblen Endoskopen. Selbstverständlich ist der Kamerakopf einlegbar.

## Technische Daten

XT 301/00 PAL - XT 301/01 NTSC

CCD Sensor:	1/3" Chip
Video-Auflösung:	750 horizontale Bildlinien
Minimale Beleuchtung:	0,9 Lux
Video-Ausgang:	FBAS oder Y/C (S-VHS)
Elektr. Versorgung:	100/115VAC und 230/240VAC
Gewicht:	2 kg

## Weiteres Zubehör

- XT 301/02 Kamera mit C-Mount Gewinde PAL
- XT 301/03 Kamera mit C-Mount Gewinde NTSC
- XT 306/00 Bildteiler
- XT 361/40 Zoom Adapter 15 - 25 mm
- XT 361/50 Zoom Adapter 25 - 40 mm
- verwendbar mit XT 301/02 und XT 301/03

## Description XT 301/00 / XT 301/01

nopa cam m is the consequent improvement of our camera system. Besides all the previous functions further special functions have been realized. An integrated control of peripheral devices (VCR, printer), as well as the Gain Control can be operated with the help of two buttons directly from the camera head.

Our camera is equipped with digital contrast and colour control and a digital anti-moiré filter for use with flexible endoscopes.

The camera serves both rigid and flexible endoscopes optimally. Of course the camera head is fully immersible.

## Technical data

XT 301/00 PAL - XT 301/01 NTSC

CCD sensor:	1/3" Chip
Video resolution:	750 horizontal lines
Minimal illumination:	0,9 Lux
Video output:	FBAS or Y/C (S-VHS)
Power supply:	100/115VAC and 230/240VAC
Weight:	2kg

## Optional accessories

- XT 301/02 camera with C-mount adapter PAL
- XT 301/03 camera with C-mount adapter NTSC
- XT 306/00 beam splitter
- XT 361/40 Zoom adapter 15 - 25 mm
- XT 361/50 Zoom adapter 25 - 40 mm
- to use with XT 301/02 and XT 301/03



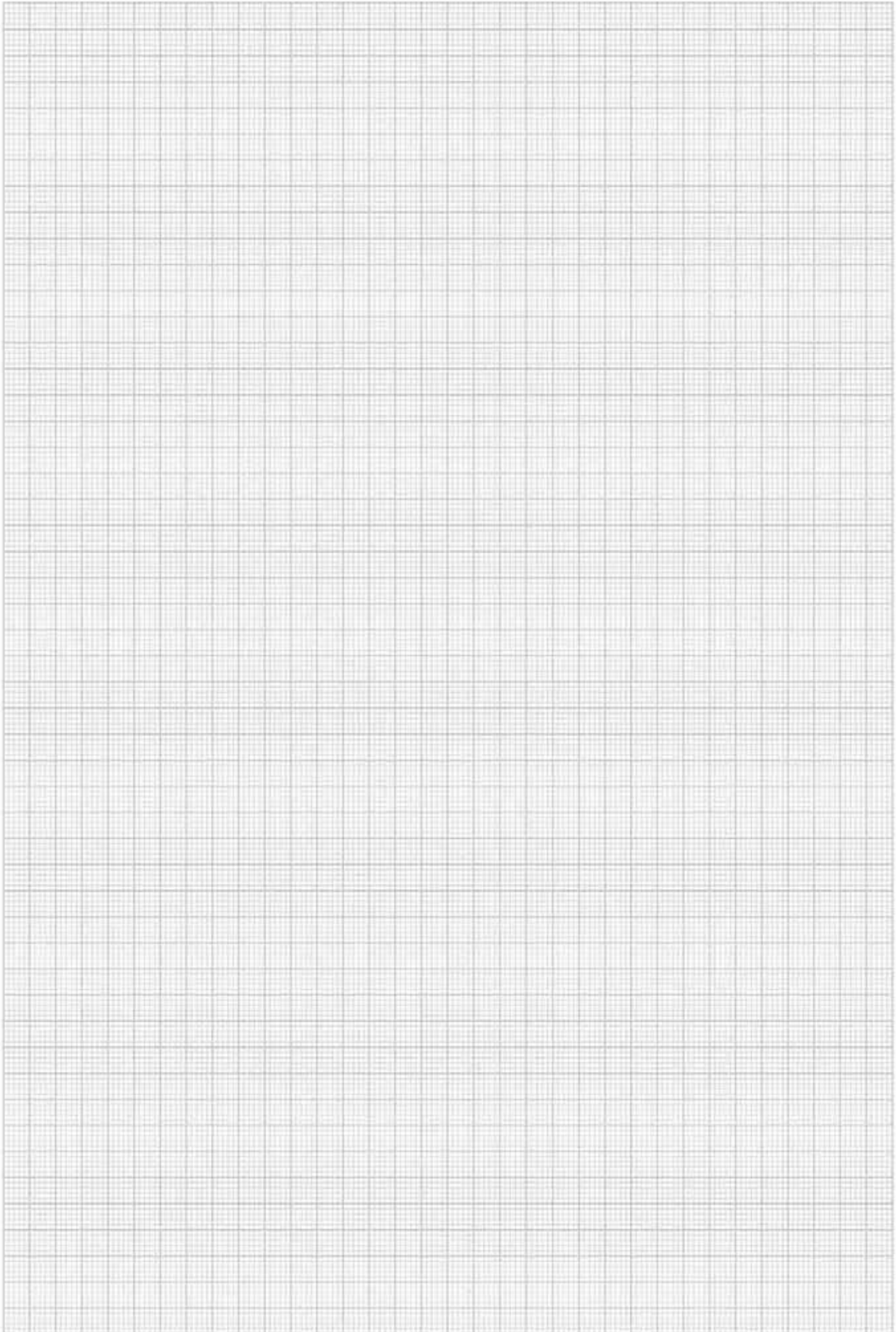

# nopa<sup>®</sup> cam digital camera system

## immersible soakable 3 - chip

### PAL/SECAM

XT 305/00	-	XT 310/00	Netzkabel/mains cord
		XT 320/05	Kamerakopf inkl. Kabel 4,0 m, einlegbar/ camera head incl. cable 4,0 m, immersible
		XT 330/05	Kameraprozessor/camera control unit
		XT 340/05	Objektiv/Objective lens
		XT 344/05	Kabel/cable S-VHS
		XT 365/25	Adapter, Optomech. Microfocus 28 mm (C-Mount)

### NTSC

XT 305/01	-	XT 310/00	Netzkabel/mains cord
		XT 325/05	Kamerakopf inkl. Kabel 4,0 m, einlegbar/ camera head incl. cable 4,0 m, immersible
		XT 335/05	Kameraprozessor/camera control unit
		XT 340/05	Objektiv/Objective lens
		XT 344/05	Kabel/cable S-VHS
		XT 365/28	Adapter, Optomech. Microfocus 28 mm (C-Mount)



### Beschreibung XT 305/00 / XT 305/01

Das nopa cam camera system future 500 ist ein hochentwickeltes 3-Chip Kamerasystem und für alle endoskopischen Eingriffe einsetzbar.

Ausgezeichnete Bildqualität, scharfe Bildzeichnung und Klarheit werden durch die drei 1/3" CCD-Chips gewährleistet.

Die optimale Bilddarstellung aufgrund eines hochempfindlichen Mikro-Linsen-Chip sowie einer äußerst schnellen Blende wird auch unter schwierigsten Beleuchtungsbedingungen sichergestellt. Der leichte, kompakte Kamerakopf ist äußerst ergonomisch und einlegbar. Alle Adapter und Coupler mit einem C-Mount-Gewinde können angeschlossen werden. Der automatische Weißabgleich wird durch Schalterdruck aktiviert und ist im Memory gespeichert.

Zusätzlich bietet das System eine "window"-Funktion um unter extremen Lichtverhältnissen eine gute Bilddarstellung zu garantieren. Größe und Einstellung dieses Spezial-Focus werden über den Druckschalter aktiviert und auf dem Monitor angezeigt.

Aufgrund des hohen Automatisierungsstandards der nopa cam future 500 ist das Kamerasystem sehr bedienerfreundlich. Kamerakopf und Kabel sind einlegbar.

### Technische Daten

XT 305/00 PAL - XT 305/01 NTSC

CCD Sensor:	3 x 1/3" Chip (3 x 440000 pixel)
Video-Auflösung:	über 750 Linien
Elektronische Blende:	max. 1/2000000 sec.
Minimale Beleuchtung:	3 Lux F1.4
Video Ausgang:	FBAS, Y/C (S-VHS), RGB
Elektr. Versorgung:	110/115VAC - und 230/240VAC
Gewicht:	3,5 kg

### Weiteres Zubehör

- XT 365/15 Adapter optomechanisch microfocus 15 mm
- XT 365/21 Adapter optomechanisch microfocus 21 mm
- XT 365/35 Adapter optomechanisch microfocus 35 mm
- XT 364/10 Microfocus-Adapter, flexibel Pentax
- XT 366/10 Microfocus-Adapter, flexibel Olympus
- XT 368/10 Microfocus-Adapter, flexibel Fujinon

Bei Bestellung bitte Netzspannung angeben.

### Description XT 305/00 / XT 305/01

The nopa cam camera system future 500 is a highly developed three chip camera system which can be used for all operations performed with endoscopes. Excellent picture quality, sharp picture delineation and clarity are guaranteed by the three 1/3" CCD chips.

Optimal picture presentation is ensured by a highly sensitive micro-lens chip with an extremely rapid diaphragm even under difficult lighting conditions. The light, compact camera head is ergonomic and immersible. All adapters and couplings with a C-mount thread can be connected. The automatic white compensation is activated by press button and is stored in the memory.

The system additionally offers a "window" function to ensure a good picture representation under extreme lighting conditions. The magnitude and setting of this special focus are activated by press button and displayed on the monitor screen.

The nopa cam future 500's high standard of automatic operation makes this camera system extremely easy to operate. The camera head and cable can be immersed.

### Technical data

XT 305/00 PAL - XT 305/01 NTSC

CCD sensor:	3 x 1/3" chip (3x 440000 pixel)
Video resolution:	more than 750 lines
Electronic shutter:	max. 1/2000000 sec.
Minimal illumination:	3 Lux F1.4
Video output:	FBAS, Y/C (S-VHS), RGB
Power supply:	110/115VAC - and 230/240VAC
Weight:	3,5 kg

### Optional accessories

- XT 365/15 Adapter optomechanical microfocus 15 mm
- XT 365/21 Adapter optomechanical microfocus 21 mm
- XT 365/35 Adapter optomechanical microfocus 35 mm
- XT 364/10 Microfocus-a dapter, flexible Pentax
- XT 366/10 Microfocus-a dapter, flexible Olympus
- XT 368/10 Microfocus-a dapter, flexible Fujinon

Please indicate the voltage when placing the order



Gelenkarmsystem mit zentraler Schnellfixierung  
 Articulated arm with quick central fixation  
 Sistema de brazo articulado con fijación rápida central  
 Système de bras articulé avec fixation rapide central  
 Sistema a braccio articolato con fissaggio rapido centrale



**Komplett kurz / short complete**

XU 650/01	=	XU 650/13 XU 650/40 XU 651/01 XU 651/12
-----------	---	--

**Komplett lang / long complete**

XU 650/02	=	XU 650/13 XU 650/55 XU 651/02 XU 651/12
-----------	---	--

Zubehör auf der Rückseite  
 Accessories reverse side

Gelenkarmsystem mit zentraler Schnellfixierung  
 Articulated arm with quick central fixation  
 Sistema de brazo articulado con fijación rápida central  
 Système de bras articulé avec fixage rapide central  
 Sistema a braccio articolato con fissaggio rapido centrale

**Halterungen  
 Holders**



XU 650/11  
 Kombi Instrumentenhalter  
 Combined Instrument holder



XU 650/12  
 Ø 4 mm Optikhalter  
 Ø 4 mm Optic holder



XU 650/13  
 Ø 5 mm/10 mm Optikhalter  
 Ø 5 mm/10 mm Optic holder



XU 650/14  
 Ø 8 mm Optikhalter  
 Ø 8 mm Optic holder

**Gelenkarme  
 Articulated arms**

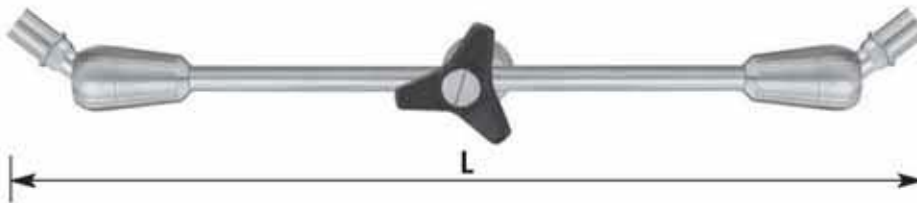

XU 650/40  
 L = 400 mm M8/M12x1 Ø 16 mm

XU 650/55  
 L = 550 mm M8/M12x1 Ø 16 mm

**Säulen  
 Columns**



XU 651/01 Ø 16 mm 300 mm  
 XU 651/02 Ø 16 mm 400 mm



XU 651/03  
 Ø 16 mm 450 mm x 100 mm



XU 651/04  
 Ø 16 mm 266 x 300 x 116 mm

**Klemmsockel  
 Clamping socket**



XU 651/11  
 Universalsockel  
 Universal clamp



XU 651/12  
 Schienensockel  
 Rails clamping socket



XU 651/13  
 Isolierter Schienensockel  
 Insulated rails clamping socket

1  
3  
5  
7  
18

