



---

ATMOS Scope

# Flexible HD video nasopharyngo- laryngoscope

---

*Exactly  
what  
I need*

---

# ATMOS Scope HD USB

## for ENT Endoscopy & Swallowing Diagnostics

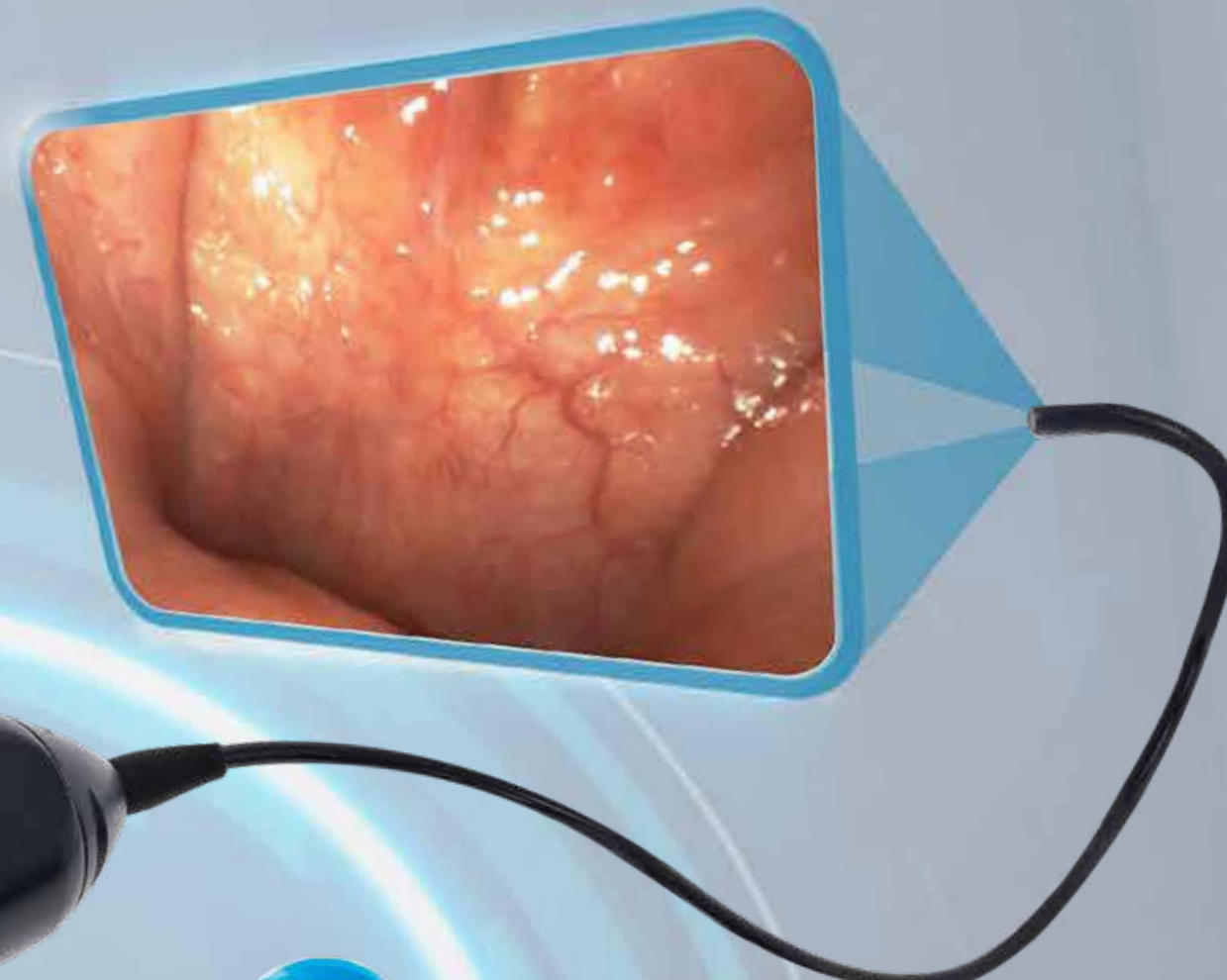

### OPERATION

- Ergonomic handle with fine-adjustable deflection lever
- Two function buttons integrated in the handle for easy software control
- Easy insertion thanks to smooth-gliding insertion tube



### CLEANING

- High-quality and robust housing
- Protection cap on the USB connection cable for additional protection of the contacts
- Suitable for manual and mechanical reprocessing including low-temperature sterilization (Sterrad®, Steris®)



### VISUALIZATION, DOCUMENTATION & REPORTING

- USB connection cable for portable end devices and direct connection to a treatment unit
- Easy visualization and storage of images and videos
- Trouble-free connection to the ATMOS 360° diagnostics platform



### IMAGE QUALITY

- Built-in HD image sensor in the endoscope tip
- Homogeneous illumination of the examination area by means of two integrated LED light sources
- Wide-angle lens with 90° field of view



ATMOS Perfect Image Quality

# Image quality? High-resolution.

**One of the first:** The second-generation ATMOS Scope is one of the first flexible endoscopes with a resolution of 800 x 800 pixels. This means that video-assisted endoscopic and swallowing diagnostic examinations can be carried out in HD quality — even with portable end devices in mobile use.

Perfect  
Image  
Quality

HD resolution

### LONG-LIFE TIP COVER GLASS

The scratch-resistant and extremely robust tip cover glass protects the distal endoscope tip of the ATMOS Scope and thus ensures a long service life.



### CMOS SENSOR

The newest generation of CMOS sensor technology features faster data processing and thus enables a comprehensive assessment — in real time and in HD.

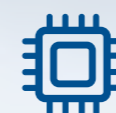

### Chip-on-tip

The ATMOS Scope's image sensor with 1280 x 800 pixels is located directly on the endoscope tip and achieves a much higher resolution than that of endoscopes with image fibers.



### Dual LED

Two integrated LED light sources ensure bright and homogeneous illumination of the entire field of view.



### Wide-angle lens

The integrated wide-angle lens in the new ATMOS Scope produces high-resolution images of the examined regions in 90° field of view.



### QUALITY MADE IN GERMANY

The entire development, production, and quality control of the ATMOS Scope endoscopes take place at our headquarters in Lenzkirch, Germany. This guarantees excellent quality — "Made in Germany."

ATMOS ErgoDesign

# Examination? Comfortable.

**Optimal for user and patient:** The new ATMOS Scope combines all the ergonomic advantages of the previous model with several technological innovations that make the examination process more comfortable for user and patient.

**USER-ORIENTED OPERATING CONCEPT**

The heat-dissipating handle allows you to perform delicate work fatigue-free — even during longer examinations. Since all function buttons are located directly on the handle, the user does not have to change the position of his or her hand during the examination.

**GREATER PATIENT COMFORT**

Patients benefit from the easy-to-insert insertion tube with its scratch-resistant tip cover glass and endoscope tip that is just 3.9 mm wide. This guarantees pain-free examinations of the nose, throat, and larynx.



**Ergo Design**  
Optimal for user and patient

**ERGONOMIC HANDLE**

The new ATMOS Scope, like the previous model, has an ergonomic handle that enables you to work precisely and fatigue-free while sitting or standing.



**FINE-ADJUSTABLE DEFLECTION LEVER**

The deflection lever can be operated smoothly with your thumb and enables you to control the endoscope tip precisely at an angle of 2 x 135°. This allows you to easily examine difficult-to-reach regions in the nose or throat.



**INTEGRATED FUNCTION BUTTONS**

To record and store snapshots and videos, the ATMOS Scope has two separate function buttons located directly on the handle. This makes it easier to operate and ensures that the user can concentrate fully on the patient.



**AUTOMATIC STANDBY MODE**

Whenever the ATMOS Scope is not being used, the light source turns off and the device automatically goes into the energy-saving standby mode. Once you pick up the endoscope again, the integrated motion sensor automatically starts the active mode.



ATMOS DirectLink

# Visualization? Documentation? Direct.

**Plug and play at its best:** The second-generation ATMOS Scope comes standard with a USB connection cable. This allows you to connect the endoscope directly to a treatment unit or even a laptop — ideal for mobile endoscopy and swallowing diagnostics.



### INTEGRATED VISUALIZATION & STORAGE FUNCTIONS

The new ATMOS Scope includes selected functions from the ATMOS visualization and documentation software called ATMOS Capture Suite. These functions allow users to perform and store endoscopic examinations more easily and conveniently.

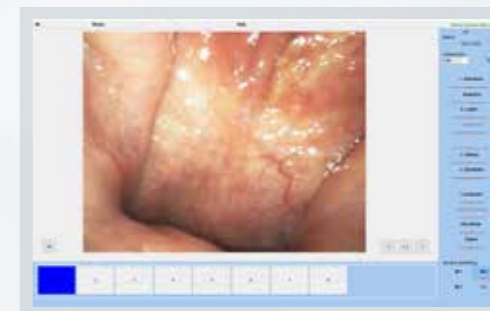

### LIVE IMAGE IN HD QUALITY

Optimized presets and the integrated light source in the ATMOS Scope make the usual camera settings and white balance unnecessary: immediately after start-up, the user obtains a live image in HD quality.

### SIMPLE RECORDING & SAVING

Two easy-to-use function buttons on the ATMOS Scope's handle make it easier than ever for users to record and store snapshots and videos.



### COMPREHENSIVE DOCUMENTATION FUNCTIONS

The new ATMOS Scope can be easily integrated into the ATMOS 360° diagnostics platform. This provides the user with additional functions of the ATMOS Capture Suite software in the areas of diagnostics, documentation, and patient management.

### NEEDS-ORIENTED POST-EDITING

Depending on your needs, the full version of the ATMOS Capture Suite also allows you to edit, cut, or comment on the captured snapshots and videos.

### CUSTOMIZABLE REPORT TEMPLATES

Tried and tested templates in PDF or Word format ensure significant time savings in the individual documentation of examination results.

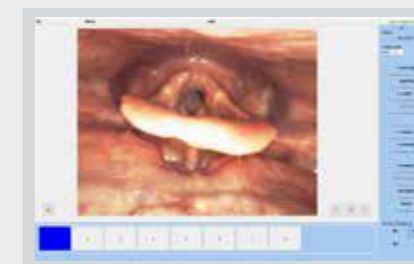

## ATMOS ComfortClean

# Reprocessing? Easy.

**Mechanical or manual:** Thorough reprocessing of the endoscope is essential for the safety of both patient and user. The new ATMOS Scope is suitable for both manual and mechanical reprocessing methods. Comprehensive and preventive maintenance and safety concepts ensure greater safety and device longevity.

### SAFE & EASY CLEANING

Regardless of whether you prefer manual cleaning or mechanical reprocessing including low-temperature sterilization, the ATMOS Scope does not need to be disassembled before cleaning. It only needs to be checked for leaks (leakage tester included in the scope of delivery) and can then be cleaned as a complete unit. The waterproof housing and the additional protection cap for the USB connection cable offer effective protection against the penetration of water and cleaning substances.



### PRODUCT-SPECIFIC MAINTENANCE & SERVICE CONCEPTS

Comprehensive and preventive maintenance and service concepts tailored specifically to your individual needs ensure additional safety and device longevity. Just talk to your ATMOS partner or contact our service team.



Maximum device longevity thanks to quick and dependable product servicing

### TECHNICAL DATA

Weight	0.4 kg
Length of insertion tube	300 mm
Diameter	3.9 mm
Image sensor	1/14.25" CMOS
Field of view	90°
Focus area	6–60 mm
Deflection angle	135°
Image resolution	800 x 800 pixels
Sensor resolution	1280 x 800 pixels

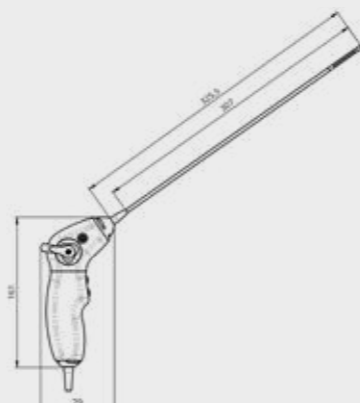



MedizinTechnik

**ATMOS MedizinTechnik GmbH & Co. KG**

Ludwig-Kegel-Str. 16  
79853 Lenzkirch / Germany

Tel +49 (0)7653-689-0  
Fax +49 (0)7653-689-190  
E-Mail [info@atmosmed.com](mailto:info@atmosmed.com)

**[www.atmosmed.com](http://www.atmosmed.com)**



Scan the QR code to  
go straight to the  
ATMOS Scope website.